

January 2023
Edition

Rules and Regulations for

**Water, Sewer, &
Reclaimed Water
Services**

(This page left blank

TABLE OF CONTENTS

Table of Contents	1
Chapter I General.....	5
1.01 Short title; purpose.....	7
1.02 Definitions.....	7
Chapter II Authority and Conditions of Service	15
2.01 General responsibilities.....	17
2.02 Free service prohibited.....	18
2.03 Supply of water.....	18
2.04 Inspections, monitoring and right of entry.....	19
2.05 Responsibility for Permits.....	19
2.06 Grounds for discontinuance of service.....	19
2.07 Certain tests authorized.....	20
Chapter III Connections to Water, Sewer, and Reclaimed Water System	21
3.01 Connections to water and sewer systems required; exceptions.....	23
3.02 Taps and connections.....	24
3.03 Water and Sewer Main Extensions.....	24
3.04 Meters and Customer Connections.....	26
3.05 Cross connections.....	27
3.06 Connection interference.....	28
3.07 Excavations.....	28
3.08 Connection maintenance.....	28
3.09 Fees.....	29
Chapter VI Service Regulations	31
4.01 Service applications.....	33
Chapter V Penalties and Liability	35
5.01 Damaging, destroying facilities prohibited.....	37
5.02 Failure to comply with notice to correct.....	37

JEA Rules and Regulations for Water, Sewer, & Reclaimed Services
Table of Content

5.03 Liability for damages caused by violations. 37
Forms 39

Appendix A Reclaimed Water

Chapter A-1 introduction..... A-1

1.01 Introduction A-1
1.02 Intent..... A-1
1.03 Purpose..... A-1
1.04 Applicability A-1

Chapter A-2 Authority A-1

2.01 Authority to adopt Rules and Regulations A-1
2.02 Authority to adopt Rates, Fees, and Charges A-1

Chapter A-3 Connection to and use of Reclaimed Water System..... A-1

3.01 Availability of Service A-1
3.02 Requirement to Connect to Reclaimed Water System..... A-2
3.03 Application for Connection to System..... A-4
3.04 Limitations of use of Reclaimed Water A-4
3.05 Discontinuance of Service by JEA A-5

**Chapter A-4 Installation/Construction Requirements for
Reclaimed Water Irrigation Systems A-5**

4.01 General A-5
4.02 Public rights-of-way and easements A-6
4.03 Backflow Prevention Devices (BPDS) A-6
4.04 Color-coding and Tagging A-6
4.05 Advisory Signs..... A-7

Chapter A-5 Cross-Connection Control A-7

Chapter A-6 Inspections..... A-8

Chapter A-7 Setback Distances A-8

**Chapter A-8 Responsibility for Ownership and Maintenance
Reclaimed Water System A-8**

JEA Rules and Regulations for Water, Sewer, & Reclaimed Services
Table of Content

8.01	JEA Responsibilities	A-8
8.02	Customer Responsibilities	A-8
Chapter A-9 Testing of Backflow-Devices		A-9
Chapter A-10 Penalties for Non-Compliance.....		A-10
10.01	Termination of Service	A-10
10.02	Monetary Penalties.....	A-10
Chapter A-11 Pertinent Sections of Local Codes.....		A-10
11.01	City Building Codes.....	A-10
Forms.....		A-12

Appendix B Cross-Connection Control Policy

Policy Statement.....		B-1
Introduction.....		B-2
Chapter B-1 Overview		B-3
1.01	Purpose.....	B-3
1.02	Causes of Backflow	B-3
Chapter B-2 Responsibilities.....		B-4
2.01	Cross-Connection Control Program.....	B-4
2.02	Customers	B-4
2.03	Backflow Prevention Assembly Installers	B-4
Chapter B-3 Inspections		B-5
3.01	Frequency.....	B-5
3.02	Proposed Constructions	B-5
3.03	New and Existing Facilities	B-6
Chapter B-4 Cross-Connection Hazards and Required Protections		B-6
4.01	Facilities – Type of Backflow Protection Required.....	B-6
4.02	Residential Premises with a Reclaimed Water System	B-9

JEA Rules and Regulations for Water, Sewer, & Reclaimed Services
Table of Content

4.03	Installations Requiring Continuous Service – Parallel Installation	B-10
4.04	Type of Backflow Protection Required – Fire Protection Services	B-10
4.05	Other Cross-Connection Hazards	B-11
Chapter B-5 Testing of Backflow Devices		B-12
Chapter B-6 Penalties for Non-Compliance		B-13
6.01	Termination of Service	B-13
6.02	Monetary Penalties and Imprisonment	B-13
Chapter B-7 Pertinent Sections of Local Codes		B-13
7.01	City Building Code - Chapter 341	B-13
Chapter B-8 Backflow Prevention Devices (Illustrated)		B-14
8.01	Air gap separation	B-14
8.02	Double Check Valve Assembly	B-15
8.03	Double Check Detector Backflow Assembly	B-15
8.04	Reduced Pressure detector Backflow Assembly.....	B-16
8.05	Residential Dual Check valve.....	B-17
References		B-19

Appendix C Commercial/Industrial

Commercial/Industrial Questionnaire	C-1
--	------------

Appendix D Reclaimed Water Service Area

Reclaimed Water Service Area map	D-1
---	------------

Chapter I General

(This page left blank.)

1.01 Short Title; Purpose

This document shall be known and may be cited as JEA's Rules and Regulations for Water, Sewer, & Reclaimed Water Service. The purpose of this document is to set uniform requirements for users of JEA's potable water system, wastewater collection system and reclaimed water distribution system, to enable JEA to comply with the provisions of the Safe Drinking Water Act (42 U.S.C.), Clean Water Act [33 U.S.C. §§1251 et seq.] and other applicable federal and state laws and regulations; and to provide for the public health and welfare by regulating the quality of potable water supplied to JEA's service territory; and wastewater discharged into JEA's wastewater collection system; and the use of reclaimed water. This document:

1. Provides a means for determining water and wastewater volumes, constituents and characteristics.
2. Establishes standards for the installation and use for reclaimed water as outlined in Appendix A Reclaimed Water.
3. Establishes procedures and policies for safeguarding the integrity and quality of the potable water supply.
4. Provides measures for the enforcement of its provisions and abatement of violations thereof.
5. Establishes the duties of JEA's Managing Director and Chief Executive officer to insure that the provisions of this document are administered fairly and equitably to all users.
6. Establishes procedures and policies to protect JEA's potable water supply from cross-connection in accordance with Florida Administration Code 62-555.360 as outlined in Appendix B Cross-Connection Control Policy.

1.02 Definitions

The following words, terms, and phrases, when used in this document, shall have the meanings ascribed to them in this section, except where the context clearly indicates a different meaning.

1. **Abutment** is defined as customer's property that is adjacent, and joins at the border of a right-of-way or utility easement where the JEA point of utility connection exists: *This piece of land abuts on a street.*
2. **Act or the Act** means the Federal Water Pollution Control Act, also known as the Clean Water Act, as amended.
3. **Air-gap separation** The term air-gap separation shall mean a physical separation between the free flowing discharge end of a potable water supply pipeline and an open or non-pressure receiving vessel. An approved air-gap separation shall be a distance of at least two (2) times the diameter of the supply pipe measured vertically above the top rim of the vessel, with a minimum distance of one (1) inch.

4. **Alternative Connection Committee** is comprised of a group of JEA Directors responsible for providing cost effective service for new customer connections in JEA's service territory. JEA recognizes that alternatives to traditional service connections to its utility system may exist and reserves the right to approve or deny their use based on best available information.
5. **Approved** Accepted by JEA as meeting an applicable specification of the Cross Connection Policy and approved by the Department of Environmental Regulation, State of Florida, or their designee.
6. **Atmospheric vacuum breaker** An approved assembly consisting of a check valve and an air inlet to relieve a vacuum. It shall effectively shut off the reverse flow of water when a negative pressure exists on the supply side of the device.
Note: Only approved for internal plumbing.
7. **Authorized representative** of industrial user may include any one of the following:
 - a) A principal executive officer of at least the level of vice president, if the industrial user is a corporation.
 - b) A general partner or the proprietor, if the industrial user is a partnership or a proprietorship, respectively.
 - c) A duly authorized representative of an individual designated above if the representative is responsible for the overall operation of the facility from which the indirect discharge originates. Authorization shall be made in writing and submitted to JEA Industrial Pretreatment Office.
8. **Auxiliary water supply** Any water supply on or available to the premises other than the purveyors' approved public potable water supply. These auxiliary waters may include water from a private non potable water supply or any natural source(s) such as a well, spring, river, pond, stream, harbor, etc., or used water or industrial fluids. These waters may be contaminated or they may be objectionable, and constitute an unacceptable water source over which the water purveyor does not have sanitary control.
9. **Backflow** The flow of water or other liquids, mixtures or substances under pressure into the distribution pipes or a potable water supply system.
10. **Backflow prevention assembly** A backflow prevention assembly shall mean any effective assembly method or construction used to prevent backflow into a potable water system. The type of assembly used should be based on the degree of hazard, either existing or potential.
11. **Backflow prevention assembly (approved)** The term approved backflow prevention assembly shall mean an assembly that has met the requirements of University of Southern California Foundation for Cross Connection Control and Hydraulic Research (USC-FCCC).
12. **Backflow prevention assembly tester** A person who has proven their competency to the satisfaction of JEA. Each person who is certified to make

competent tests and make reports on backflow prevention assemblies shall be conversant with applicable laws, rules and regulations and shall have attended and successfully completed a Certification Program for Backflow Prevention Testers acceptable to JEA.

13. **Backflow Prevention Devices (BPD)** means a device or means designated to prevent backflow or back-siphonage. Most commonly categorized as air gap, reduced pressure principle assembly, double check valve assembly, detector check assembly, pressure vacuum breaker, atmospheric vacuum breaker, hose bib vacuum breaker, and dual check.
14. **Backsiphonage** The flow of water or other liquids, mixtures or substances into the distributing pipes or potable water supply system from any source other than its intended source, caused by the reduction of pressure in the potable water system.
15. **Backpressure** Is any elevation of pressure in the downstream piping system (by pump, elevation of piping, or steam and/or air pressure) above the supply pressure at the point of consideration which would cause or tend to cause, a reversal of the normal flow.
16. **Board** JEA Board of Directors.
17. **Building sewer** means the extension from the building drain to the public sewer or other place of disposal.
18. **Contamination** An impairment of the quality of the potable water by any solid, liquid, or gaseous compounds or mixtures to a degree which would create an imminent danger to the public health, or would create an unacceptable taste, odor or color to the potable water.
19. **Control authority** means JEA.
20. **County** means Duval, Clay, St. Johns, or Nassau Counties, political subdivisions of the State of Florida.
21. **Customer or User** means any person, firm, corporation, or governmental entity, using or receiving water from JEA reclaimed water system. Reclaimed water customers are further classified as follows
 - a) **Retail**: means any individual customer served by a single meter 3-inches or less in size, where access to another source of non-potable water for irrigation is unavailable. Includes but is not limited to: residential customers; individual commercial establishments, common areas and greenways of subdivisions.
 - b) **Bulk**: means any commercial or industrial customer served by one or more meters 3-inches in size or greater, downstream or which there are no retail customers. May include, but not limited to: certain multi-family residential complexes; commercial tracts occupied by more than one tenant; industrial users; golf courses, parks and playgrounds; schools;

cemeteries; etc. Bulk customers must receive reclaimed water service into a pond or tank owned by the customer.

Retail customers are the least interruptible class of customers. Therefore, retail customers will be the last customers to be shut down in the event of a reclaimed water shortage and may expect to pay higher rates for the service than the other class of customers.

22. **Cross-connection** Any physical connection or arrangement of piping or fixtures between two otherwise separate piping systems, one of which contains potable water and the other non-potable water or industrial fluids of questionable safety, through which or because of which, backflow or backsiphonage may occur into the potable water system. A water service connection between a public potable water distribution system and a customers' water distribution system which is cross-connected to a contaminated fixture, industrial fluid system or with a potentially contaminated supply or auxiliary water system constitutes a type of cross-connection. Other types of cross-connections include connectors such as swing connections, removable sections, four-way plug valves, spools, dummy sections of pipe, swivel or change-over devices, sliding multi-port tube, solid connections, etc.
23. **Degree of hazard** A qualification of what potential and actual harm may result from cross-connections within a water using facility. Establishing the degree of hazard is directly related to the type and toxicity of contaminants that could feasibly enter the public water supply system and is determined by JEA.
24. **Department** means the Florida Department of Environmental Protection (FDEP) having jurisdiction within the Utility Service Area.
25. **Director** means JEA's Managing Director and Chief Executive officer or agent or representative unless a specific reference is made to another named department.
26. **Distribution Main** means those conduits used to supply reclaimed water from transmission mains to service lines.
27. **District** means the St. Johns River Water Management having jurisdiction within the Utility Service Area.
28. **Double check valve assembly** an assembly composed of two single, independently acting, approved check valves, including tightly closing shut-off valves located at each end of the assembly and fitted with properly located test cocks.
29. **Double check detector backflow assembly** is a specially designed assembly composed of a line-sized approved double check valve assembly with a bypass containing a specific water meter and an approved double check valve assembly. Meter will register very low flows of water up to three gallons per minute and shall show a registration for all rates of flow. This assembly should only be used against a non-health hazard (i.e., pollutant).

30. **DRI** Development of Regional Impact.
31. **Emergency** means conditions causing danger or severe inconvenience to health and safety, including contamination, severe water shortages, major breakdowns or threats of war or weather disaster.
32. **Environmental Protection Agency or EPA** means the United States Environmental Protection Agency and, where appropriate, the Administrator or other duly authorized official of the EPA.
33. **FAC** Florida Administrative Code
34. **Fire Protection Water Service – Open System** is an unmetered single water service which is dedicated for fire protection to a premise on a stand-by basis; no hose bibs or other types of connections are allowed; and may have external connection that may ONLY be used for fire suppression; such as hydrants and/or standpipes.
35. **Fire Protection Water Service – Closed System** is an unmetered single water service which is dedicated for fire protection to a premise on a stand-by basis; no hose bibs or other types of connections are allowed; and connects directly to a buildings fire sprinkler system and has no external connections such as hydrants or standpipes.
36. **Health hazard** An actual or potential threat of contamination or pollution of a physical or toxic nature to the public potable water system or the consumers' potable water system to such a degree or intensity that there would be a danger to health.
37. **Individual water supply** means a well or other source of water, and pump and piping if any, located on the premises served, for supplying only a single home or family or commercial or industrial establishment.
38. **Industrial piping system (customers)** any system used by the consumer for transmission of or storage of any fluid, solid or gaseous substance other than an approved water supply. Such a system would include pipes, conduits, tanks, receptacles, fixtures, equipment and appurtenances to produce convey or store substances which are or may be polluted or contaminated.
39. **In-plant** Any pipe, system of pipes or other associated facilities located inside a processing plant or manufacturing plant that are not part of the public water system and are used in whole or in part to move or receive water regardless of the source.
40. **Low Pressure** refers to distributions lines that are not connected to storage facilities and the line pressure may vary due to usage or supply.
41. **Non-Residential** means land development project intended for construction of infrastructure improvements for non-residential unit(s).
42. **Pollution** means the man-made or -induced alteration of the chemical, physical, biological and radiological integrity of water.
43. **Potable Water** means water from any source which has been approved for human consumption by the utility and appropriate regulatory agencies.

44. **Premise or Premises** means a parcel of real estate or portion thereof including any improvements thereon which is determined by the Manager of Industrial Pretreatment to be a single user for purposes of receiving, using and paying for services.
45. **Pressurized** refers to distributions lines that are connected to storage facilities and may have a constant supply and pressure.
46. **Public Health Officer** means the Public Health Officer of the city, or his authorized deputy, agent or representative.
47. **Public sewer** means a sewer in which all owners of abutting properties have equal rights and which is controlled by public authority.
48. **Reclaimed Water (Non-Public Access)** in the context of this document, means wastewater that has received at least secondary treatment, filtration, and basic level disinfection after treatment and discharge from a domestic wastewater treatment facility as specified in Rule 62-610.410, Part II, or Rule 62-610.652, Part VII, Florida Administrative Code (FAC), for the purpose of reuse in areas of restricted public access.
49. **Reclaimed Water (Public Access)** in the context of this document, means wastewater that has received at least advanced secondary treatment, filtration, and high-level disinfection after treatment and discharge from a domestic wastewater treatment facility as specified in Rule 62-610.460, Part III, Florida Administrative Code (FAC), for the purpose of reuse in areas of special conditions public access.
50. **Reduced pressure backflow preventer** An assembly containing within its structure a minimum of two independently acting, approved check valves, together with an automatically operating pressure differential relief valve located between the two check valves. The first check valve reduces the supply pressure a predetermined amount so that during normal flow and at cessation of normal flow the pressure between the check valves shall be less than the supply pressure. In case of leakage of either check valve the differential relief valve, by discharging to atmosphere, shall operate to maintain the pressure between the check valves at less than the supply pressure. The unit shall include tightly closing shut-off valves located at each end of the assembly and each assembly shall be fitted with properly located test cocks.
51. **Reduced pressure detector backflow assembly** A specially designed assembly composed of a line-sized approved reduced pressure principle backflow prevention assembly with a bypass containing a specific water meter and an approved reduced pressure principle backflow prevention assembly. The meter will show low flows of up to three gallons per minute. Assembly will protect against non-health hazard (i.e., pollutant) or a health hazard (i.e., contaminant).
52. **Residential** means a user, which is a single residential dwelling unit, served by an individual meter.

53. **Residential dual check** An assembly composed of two single, independently acting, approved check valves, including tightly closing shut-off valves located at each end of the assembly.
- a) The check valve shall permit no leakage in a direction reverse to the normal flow. The closure element (e.g., clapper) shall be internally weighted or otherwise internally loaded to promote rapid and positive closure. This assembly shall only be used as added protection to protect against a non-health hazard (i.e., pollutant).
54. **Reuse or Use** in the context of reclaimed water, means the deliberate application and use of reclaimed water, in compliance with FDEP rules.
55. **Reuse Service Area** means a geographic area within JEA’s Utility Service Area where the reclaimed water system exists or shall be expanded to provide reclaimed water service. The latest revision to the service area is shown in Appendix D – Reclaimed Water Service Area.
56. **Service** can means any of the specific utilities (Water, Reclaimed Water, and/or Sewer) that is being supplied to the customer.
57. **Service Line** means the pipe used to supply JEA service from the distribution or collection main to the property line.
58. **Sewage** means a combination of the water-carried wastes from residences, business buildings, institutions and industrial establishments, together with the ground, surface and storm waters as may be present.
59. **Sewage system** means all facilities for collecting, pumping, treating and disposing of sewage.
60. **Transmission Mains** means those conduits used to supply reclaimed water from the pumping station or treatment plant to the distribution mains.
61. **Utility appurtenance** means any devices connected to JEA’s water, sewer, and/or reclaimed water utility systems. (i.e. fire hydrant, valve, manhole, sewer pod, stand pipe, meter, delivery station)
62. **Utility Service Area** means a geographic area wherein JEA provides a utility service, such as reclaimed water supply service.
63. **Wastewater** means a combination of the water-carried wastes from residences, business buildings, institutions and industrial establishments, together with the ground, surface and storm waters as may be present.
64. **Water system** means all facilities for producing, treating and distributing water, except wells not exceeding two inches in diameter.
65. **Waters of the state** means any water, surface or underground, within the boundaries of the state.
66. **Pressure vacuum breaker** An assembly containing an independently operating, internally loaded check valve and an independently operating internally loaded air inlet valve located on the discharge side of the check valve. The assembly is to be

equipped with properly located test cocks and tightly closing shut-off valves attached at each end of the assembly.

67. **Water purveyor** The owner or operator of the public potable water system supplying an approved water supply to the public. The utility shall be one that is operating under a valid permit from the Department of Environmental Protection. As used herein the terms water purveyor and JEA may be used synonymously.
68. **Water system (customer)** Any water system located on the consumers' premises, whether supplied by a public potable water system or an industrial piping system.
69. **Water (used)** Any water supplied by a water purveyor from a public potable water system to a customers' water system after it has passed through the point of delivery and is no longer under the sanitary control of the water purveyor.

Chapter II Authority and Conditions Of Service

(This page left blank.)

2.01 General Responsibilities

1. JEA shall have charge of:
 - a) Construction, operation and maintenance of the physical facilities comprising the sewer and water systems of JEA on public property and as may be specifically acknowledged and accepted by JEA on certain private property.
 - b) Administering this document.
 - c) Reviewing and approving all plans and specifications for construction or modification of wells, pumping equipment, treatment, distribution systems collection systems, and other appurtenances prior to their being forwarded to the Florida Department of Environmental Protection in accordance with Chapters 62-555, 62-550, 62-604, Florida Administrative Code.
2. The Florida Department of Environmental Protection shall:
 - (a) Maintain surveillance over the construction, operation, and maintenance of public water systems as outlined in Chapters 62-555 and 62-550, Florida Administrative Code.
 - (b) Maintain surveillance over the construction, operation, and maintenance of public wastewater systems as outlined in Chapters 62-600, 62-601, 62-604, Florida Administrative Code.
3. The Public Health Officer shall:
 - a) Maintain surveillance over the operation and maintenance of Limited Use and Single/Multi Family private water systems as outlined in Chapter 64E, Florida Administrative Code, including the operation of the City Public Health laboratory to ensure compliance with chemical and bacteriological analysis standards.
 - b) Review plans and approve the construction and maintenance of septic tank and sand filter installations in accordance with Chapter 64E-6, Florida Administrative Code.

The Director of the Environmental Quality Division shall have jurisdiction over the discharge of waste water, treated or untreated, through public watercourses in accordance with Title X.

2.02 Free Service Prohibited

Except as otherwise provided under Florida law as set forth below, no free sewerage, reclaimed water, or water service shall be furnished or rendered to a person (herein, any legal entity) or to the city, state or a public agency or instrumentality. Every user of the JEA's water, reclaimed water, and sewerage system shall be subject to the equal and uniform rates and charges.

Exception: Exemption for Public Educational Facilities: Under Florida law, Section 1013.371, Florida Statutes, all public educational and ancillary plants constructed

by a board, as those terms are defined in Section 1013.01, Florida Statutes, are exempt from impact fees or service availability fees, including sewerage or water capacity fees.

2.03 Supply of Water

1. JEA shall not guarantee an uninterrupted supply of water or reclaimed water. JEA shall not guarantee water or reclaimed water at a particular pressure and shall have the right to shut off the water or reclaimed water in its main at a time for the purpose of making repairs or extensions or for other purposes incidental to the public water supply. JEA will not be responsible or liable for damage caused by low pressure or no service. JEA shall have the right to turn off water or reclaimed water service at the main for the protection of JEA or the user in cases where; a cross-connection has been identified; a backflow device is required and has not been installed, tested or repaired as required; a building has been burned or torn down; the consumer has been found to be using water illegally, and to assess the regular schedule of fees for restoration of service.
2. In the event of an emergency, the Managing Director and Chief Executive Officer shall immediately employ any remedial means necessary to protect life, property or the general health and safety of the water, sewer, and reclaimed water customers or the general public as related to the provision of water, sewer, and reclaimed water services.

2.04 Inspections, Monitoring And Right Of Entry

1. Whenever required to carry out the objective of this document JEA's authorized representative, upon presentation of their credentials will be permitted to enter upon any premises connected with JEA's water, sewer, or reclaimed water system for the purpose of;
 - a) Inspection, observance, or repair of the water supply, reclaimed water supply, sewage collection pipes, low pressure sewer stations, or vacuum stations.
 - b) To repair water, reclaimed water, or meters thereon measuring the water which is or may be discharged into the sewer system.
 - c) The inspection and use of reclaimed water as required in Appendix A of this document.
 - d) To test and certify a backflow device belonging to a Residential Customer.
2. JEA's authorized representative, will have access to the premises, at reasonable times,
 - a) To inspect for the possibility of a cross-connection of JEA's potable water supply with any non-potable water supply.
 - b) In cases of suspected tampering.
 - c) To install, replace, read, or test water, reclaimed water, or meters thereon measuring the water which is or may be discharged into the sewer system.

- d) To inspect, test, or maintain; backflow devices; low pressure sewer station; vacuum station; whether owned by or simply operated by JEA.
3. Denial of entry; consequences.
- a) In the event a water, reclaimed water, chilled water, or sewer user denies JEA's authorized representative the right of entry to or upon the user's premises to perform any tasks listed in part 1 or 2 of section 2.04 shall request the Office of General Counsel to use such legal procedures as are advisable and reasonably necessary to enable them to discharge and perform their duties under this part.

2.05 Responsibility for Permits

Upon approval of plans, the customer shall secure the building, electrical, plumbing or other permits required by law and proceed to construct any necessary facility and establish such operating procedures as are required.

2.06 Grounds for Discontinuance of Service

Water, Sewer, or Reclaimed Water Service may be discontinued by JEA for:

1. Interference or tampering with; the meter measuring the water or reclaimed water supply or sewer collected; the seals of a meter; or another portion of the system which was or is required by JEA for controlling or regulating the utility services.
2. Misrepresentation or concealment in the application as to the premises or fixtures to be furnished with water or sewer service or the use to be made of the service.
3. Nonpayment of charges imposed by JEA.
4. Refusal or neglect to comply with a requirement of JEA as to meter or service connection, maintenance, alteration or renewal, or other requirement relating to the sewer, water, or reclaimed water services.
5. Use of water, sewer, or reclaimed water service for or in connection with or for the benefit of a user or purpose other than as described in the application.
6. Waste or excessive use of water through improper or imperfect pipes, fixtures or appliances or any other manner.
7. Service will not continue to be supplied to a building or property which has been condemned by lawful authority.

2.07 Certain Tests Authorized

JEA is hereby authorized to grant a permit to a qualified company, corporation, association or individual to perform on JEA-owned property certain tests and evaluations related to water, reclaimed water, and sewer services, provided the following conditions are complied with:

1. There is no cost to JEA,
2. The permittee shall be properly insured and/or bonded, and
3. The permit shall contain a hold harmless clause or agreement protecting JEA.

JEA Rules & Regulations For Water, Sewer & Reclaimed Service
Chapter II: Authority And Conditions of Service

Chapter III Connections to Water, Sewer, and Reclaimed Water System

(This page left blank.)

3.01 Connections to Water and Sewer Systems Required;

1. The owner, tenant or occupant of each lot or parcel of land which abuts upon a street or other public right-of-way containing a main or lateral of JEA's water and/or reclaimed water system and which is served or may be served by JEA's system, and upon which lot or parcel a building shall have been constructed for residential, commercial or industrial use shall connect the building with the main or lateral and shall cease to use any other water supply, except as follows:

Exceptions;

- a) No person shall be required to use or connect to JEA's water supply for the purpose of landscape irrigation or recreational use. Upon written approval of JEA, a person may not be required to connect to JEA's water supply for process use, which is commercial use of water not intended for human consumption.
 - b) No private residence shall be required to use or connect to JEA's water supply if the person's water supply is served by a well, until such time as water shall cease to be available from the well without substantial alteration of the well, or the water from the well does not conform to state and local health standards. Upon failure of the well to meet the requirements of this exception, the private resident will be required to make application to JEA for service (see section 4.01 of this document).
 - c) Exceptions may be granted by the Alternative Connection Committee for issues identified by the Regulatory Agency (FDEP, Health Department, EQD, etc.) that prevent preferred system connections. Example: potable water well contamination may warrant an exception
2. The owner, tenant or occupant of each lot or parcel of land which abuts upon a street or other public way or place containing a sanitary sewer of JEA's sewer system which is served or may be served by the sewer system and upon which lot or parcel a building shall have been constructed for residential, commercial or industrial use shall connect the building with the sanitary sewer and shall cease to use any other method for the disposal of sewage, sewage waste or other polluting matter within 365 days after written notification that the system is available for connection as required in Florida Statute 381.00655; provided, that connection shall not be required to be made by an owner, tenant or occupant who, on December 23, 1968, was disposing of sewage, sewage waste or other polluting matter after pretreatment through a sewage treatment plant, other than a septic tank, which had been approved by the County Public Health Unit and who shall thereafter operate and maintain such pretreatment in compliance with state law; and further provided, that privately-owned sewage treatment facilities which are not utilities, having a treatment capacity of less than thirty thousand gallons a day, may continue in operation subject to the provisions of this subsection relating to required connections to JEA's sewer system, but premises served by the facilities having a greater treatment capacity shall not be required to connect to JEA's sewer system pursuant to this document.

3. Whenever JEA finds that a person has not made the connections required under this section, they shall direct the person by written notice by United States mail or by personal service to make or cause to be made the connections within ninety days from the date notified. It shall be unlawful for a person required to connect a building with JEA's water or sewer system to fail, neglect or refuse to make or cause to be made the connection within the time specified in the notice.
4. JEA shall not be obligated to a private person for the recovery of an investment in temporary private sewer facilities by reason of required connection to JEA's regional water and sewer system.
5. JEA shall not connect any customer that does not abut a Water/Sewer, or Reclaimed Water mains without the construction of a mainline extension.
6. Customer's property address must abut JEA utility unless it is a corner lot.
7. Properties that are subdivided and render existing customer property to not abut a main, JEA will require a main extension to be funded by the owner of the new parcel in order to serve the existing customer's property.
8. Any customer requesting service from JEA's water, sewer, or reclaimed water systems that has been disconnected or not in service for ten (10) years or longer will be required to pay for full service installation and all associated fees.
9. The requirement for minimum parcel size meeting the abutment rule is 3 times depth of sewer or 10 feet, whichever is greater. Customers whose property does not abut, but choose to purchase property that does abut in order to comply with the abutment rule for service connection, shall provide a Warranty Deed with Title Policy, complete with sketch and associated legal description for JEA Real Estate review and approval and JEA plan approval (both, prior to recordation by Customer).

3.02 Taps and Connections

Connections to mains of JEA's water, sewer, or reclaimed water system(s) shall be made only by JEA or under the supervision of JEA. New taps shall be applied for by the owner or authorized agent on a regular tap application form furnished by JEA. A tap application will not be accepted by JEA if the water meter or sewer service location is unspecified. Should it become necessary to renew, relocate or increase the size of a tap or service line, JEA will determine whether a new tap application is necessary.

For commercial taps and services contact the Water and Sewer Counter at 665-5260 for the availability of service and information on the applicable fees. No service will be deemed available where the applicant's property does not abut a main line or where a water or reclaimed water service will be required to be longer than 100 feet in length. The applicant will be referred to section 3.03 of this document for their options to obtain service through a main extension.

3.03 Water and Sewer Main Extensions

When a water or sewer main extension is required to provide residential water or sewer service it is handled in one of three different ways:

1. Customer Funded Main Extensions

A customer may request a Water/Sewer or Reclaimed Water main extension to their property or properties (not to exceed ten properties or five hundred feet for any one extension). JEA will provide an estimate for the total construction cost (this does not include the cost of the water meter/s, water plant capacity or the growth capacity fees) to design, construct, manage, inspect and place the water or sewer main, service laterals and meter boxes into service. The customer will pay the amount of the estimate in advance of any work being performed. After the Water/Sewer or Reclaimed Water main extension is complete, the customer will apply and pay the “meter” and “capacity fees.” Customer’s interested in utilizing this method will contact JEA at 665-4469 or 665-4406.

2. Florida Department of Environmental Protection (FDEP) Well Contamination Program

In areas where JEA serves and where the FDEP has identified a cluster of contaminated well sites that could cost effectively be provided potable water through the construction of a new public water main, JEA will work with the FDEP to partially fund a water main extension. Once an area has been established by JEA and the FDEP and both agencies have agreed to fund the project, most costs associated with the project are borne by the two agencies. The exception is those homes abutting the water main extension that have not been identified by the FDEP as having contaminated wells. These owners, if they chose to tie into the new water main, will apply and pay for a “meter only” and check valve to be set at the locations where the meter boxes have been placed and if they have an irrigation system, pay for a JEA approved backflow device to be installed by the plumber. The customers will make application to the *Pre-Service Counter* on the first floor of the Customer Service building at 21 West Church Street in downtown Jacksonville for their meters. Residential customers interested in pursuing a water main extension through the FDEP Well Contamination Program can contact JEA at 665-4469 or 665-4406.

3.04 Meters and Customer Connections

1. A water meter and meter box shall be placed by JEA at or near the property line of a property owner desiring service. Each water meter shall be located in accordance with JEA's *Water & Sewer Standards*. At no time are there to be two or more water or reclaimed water meter in parallel and connected together.
2. No water meter, service, or sewer service line shall be placed in a location where the customer's service will be caused to cross property lines or thru City or County Right-of-Way. When an existing service for a premise is relocated or reassigned to a new premise address or if a new service is requested, the service shall be brought in to accordance with all current requirements of JEA's Rules and Regulations for Water, Sewer, & Reclaimed Water Services and must be installed in accordance with JEA's Water and Sewer Standards Manual (W-1).
3. Water meter boxes shall not be encased in any concrete driveway or sidewalk. Prior to concrete construction the Customer must notify JEA of any such hazards. If notified prior to concrete construction, JEA will relocate the water service at the current rate for a new water tap. Notification after concrete installation will require payment to JEA, to remove the concrete structure and relocate the water service. JEA will install the water meter after the relocation cost is rendered. JEA will not be responsible for restoration of the concrete structure nor the affected landscaped area.
4. Water meter boxes shall be set evenly at grade, where there is existing grass. Where there is no existing grass the meter boxes shall be set 1 inch above grade. Meters will be placed within the box so that the meter dial and the curb stop point directly upwards. The meter box shall be adjusted over the meter so that the service can be cut on and off and both meter couplings are accessible without adjustment to the box.
5. The location criteria stated herein may be waived by JEA where the provisions are impractical and must be provided in writing on JEA letter head. JEA shall maintain the proper operation of all meters except as otherwise provided in this document. No repairs to meters owned by JEA shall be made other than by JEA.
6. Connections into the JEA sewer collection system shall be made at the pre-paved connection provided at the right-of-way line. No connection shall be allowed through a Siamese and/or manifold connection. In the case of connections to manholes, force mains, trunk sewers, low pressure systems or under special conditions, the connection shall be deemed available only after a field investigation and approved by Sewer Maintenance & Construction. Any connection shall be made as directed by JEA.
7. JEA shall have free access to the premises of any user of its water, reclaimed water, and/or sewer system for the purpose of inspecting, testing, or maintaining; backflow devices; low pressure sewer station or vacuum station, whether owned by or simply operated by JEA; and/ or cross connections devices.

8. A radius of 5 feet around any JEA utility appurtenances (i.e. meter box, manhole, fire hydrant, vacuum pod) shall be kept unobstructed by the customer so that the utility appurtenance can be accessed mechanically and electronically by JEA. No permanent structures (i.e. Buildings, Trees) shall be within 10 feet of any JEA appurtenances. JEA, acting through its authorized representative, shall have unobstructed access to each utility appurtenances installed on the service or services of the customer. Failure by the customer to provide unobstructed access to the utility appurtenances shall give JEA the option of estimating the billing of the customer at twice the customer's highest bill for the past twelve months, with an adjustment to actual consumption upon access to the utility device.
9. It is unlawful for a person to do anything or cause anything to be done to a water meter or its connections that will result in loss to JEA of its lawful revenue expected from the sale of water through the meter so disturbed.
10. The point of service is defined as the downstream side of the metered connection. For non-meter services the point of service will be at the property line.
11. Apartments and Multi-Family services that are master metered will be required to sub-meter all units.
12. Private sewer lift stations and their associated force mains shall be maintained by the owner. Private force mains shall remain private until discharging into a JEA maintained force main or gravity manhole. JEA force main ownership will commence at the JEA side of the branch isolation valve.
13. Any modification to a JEA service connection shall require that the service be brought into compliance with the JEA's Standards and /or Rules and Regulations.
14. Alternative sewer (low pressure system) connections/extensions are allowed for "special cases only" and must meet established criteria to be considered for approval by JEA management.
15. No Gravity Sewer connection shall be made to JEA's collection system where the first floor finished elevation of the applicant premise is not at least 18 inches higher than the rim of receiving manhole or rim elevation of the first upstream manhole.
16. For all unmetered Fire Protection Water Services a water flow monitoring device, as found in JEA Water and Wastewater Standards manual, Section 351, is required to be installed. The device shall be able to connect to JEA's network meter system. If unauthorized use is detected, JEA will have the option to require the customer to make application and payment for installation of the proper sized meter and applicable rate for the metered service.

3.05 Cross-Connections

1. No connection shall be made between JEA's water, reclaimed water, or sewer system and that of another water supply or sewage collection system except by permission of JEA's Managing Director in the form of a written agreement executed on behalf of JEA, by JEA's Managing Director, and by all parties

receiving water and/or sewer and/or reclaimed water service as a result of the connection. The written agreement shall describe those facilities to be privately owned, and shall specify all operation, maintenance and repair responsibilities associated with the provision of service in this manner, and shall explicitly indemnify, defend and hold JEA harmless from any damage occurring to private property as a result of failure of or maintenance to these privately owned systems. All such permitted connections with respect to water systems shall be equipped with backflow devices approved by the Public Health Officer and installed as stipulated in JEA's *Cross Connection Control Policy* (appendix B). All such permitted connections with respect to the sewer system shall be equipped with the appropriate valve as defined by JEA's *Water & Sewer Standards Manual*, and depending upon the method of connection to JEA's system.

2. JEA shall have the right to discontinue service in cases where an illegal connection is found and to assess an average bill for such period as it has been established that the user has been receiving service without payment for it.
3. The water, reclaimed water, or sewer service pipe for a building, lot, and/or premise shall not be laid through another building, lot, and/or premise. No person shall connect or cause to be connected a building, lot, and/or premise with the water, reclaimed water, and/or sewer service pipe belonging to or supplying another building, lot, and/or premise, except for outbuildings of common ownership and those connections permitted in 3.05 section 1 may be supplied from the same service pipe. For a violation of 3.05 section 3, the service may be discontinued until the violation is corrected. At no time are there to be two or more water or reclaimed water meter connected together.

3.06 Connection Interference

1. It is unlawful for any person to connect or interfere with a public water, reclaimed water, or sewer connection, water, reclaimed water, or sewer main, fire hydrant, or other appurtenance thereof without first receiving approval in writing from JEA.
2. Any person who connects or interferes with a public water, reclaimed water, or sewer connection, water, reclaimed water, or sewer main, fire hydrant or other appurtenance thereof without first obtaining written approval from JEA shall be guilty of a class D offense (herein defined to be a City Code violation and to be prosecuted as such).

3.07 Excavations

Excavations for water, reclaimed water, and/or sewer installations shall be adequately guarded with barricades and lights so as to protect the public from hazard. Streets, sidewalks, parkways and other public property disturbed in the course of the work shall be restored in a manner satisfactory to JEA or the governing agency.

3.08 Connection Maintenance

1. The property owner shall be responsible for maintaining, at their expense, the condition for free flow in the building sewer to the connection with the utility's sewer main to the extent that the owner shall be responsible for the maintenance. In the event the blockage cannot be removed by the property owner or acting agent, they shall notify JEA. Upon determination that the blockage is the responsibility of the owner lodging the complaint or any other JEA customer, JEA shall hold the property owner or acting agent that caused the blockage responsible for any damages and all costs for repairs. In the event the blockage is due to damage to pipes owned by JEA and individual responsibility cannot be determined, JEA shall affect the necessary repairs at its expense.
2. Service lines from the meter or sewer connection to and on the property owner's premises for service shall be installed without expense to JEA in conformance with the specifications of the building code.
3. The property owner shall be responsible for maintenance of water pipes connecting the building served with the outlet side of the meter.
4. Backflow protector installation and periodic testing frequencies are required as specified by JEA's Cross Connection Control Policy (Appendix B). **Backflow Assembly Fees shall be included in JEA's Rate Document.**

3.09 Fees;

1. When reconnecting an existing or applying for a new water, reclaimed water, and/or sewer service the following fees may apply:
 - a. Meter Fee
 - b. Tap Fee – (The installation of a connection for service)
 - c. Plant Capacity Fee
 - d. Growth Capacity Fee - A Growth Capacity Fee is applicable, if service address does not have an existing potable water/sewer service connected.
 - e. Retrip Fee – A Retrip Fee will be billed to the applicant if JEA is unable to set the meter.
2. When reconnecting an existing water, reclaimed water, and/or sewer service the following fees may apply:
 - a. Reconnect Fee
 - b. Meter Fee
 - c. Tap Fee
 - d. Capacity Fee
 - e. Growth Capacity Fee - A Growth Capacity Fee is applicable, if service address does not have an existing potable water/sewer service connected.

- f. Retrip Fee – A Retrip Fee will be billed to the applicant if JEA is unable to set the meter.

For detailed information on Fees please refer to JEA's Rates and Tariffs located on JEA.com. <http://www.jea.com/services/watersewer/rates.asp>

Chapter IV Service Regulations

(This page left blank.)

4.01 Service Applications

1. The agent, trustee, receiver, administrator, executor or other person handling property for an owner or tenant who applies for water or sewer service on behalf of the owner or tenant shall be jointly and severally liable with the owner or tenant under the terms of the contract of application, except where the person furnishes written proof of his authority to execute the application in behalf of another, which contract shall remain in effect until formal notice has been received by JEA for discontinuance of service.
2. Application for new water, reclaimed water, or sewer connection to a premises shall be made to JEA in writing on forms provided for that purpose and shall state fully all the purposes for which the connection of water, reclaimed water, or sewer service is required and the location of the premises to be supplied, and shall be signed personally or by an agent of the owner, tenant or occupant of the premises. An application, when accepted by JEA or upon its performance of the service applied for, shall constitute a contract between those liable under 4.01 section 1 and JEA, which shall bind those liable to pay JEA for the services rendered its prescribed rates therefore and to comply with all the rules and regulations applicable to the service. Upon acceptance by JEA, the application constitutes a service contract based upon these and other JEA rules, rates and policies and becomes effective at the time the customer is connected to JEA system.
3. In the event of a change of ownership or occupancy of a premise served by JEA's water, reclaimed water, or sewer systems, the new owner or occupant shall immediately notify the JEA @ **665-6000**, of the change. If a new owner or occupant fails to give notice or fails to apply for service and if the prior owner or occupant shall have failed to terminate his contract with JEA for service, the use of the services of JEA's systems shall be deemed to be an acceptance by the new owner or occupant of all of the contract obligations of the prior owner or occupant to JEA and the new owner or occupant shall continue to be subject to all the provisions of this document as fully and completely as if the new owner or occupant had applied for service and the application had been accepted by JEA.
4. An applicant for water, reclaimed water, or sewer service may terminate their contract for the service at any time by giving formal notice to JEA at its offices and by paying all amounts due for services up to the date of receipt of the notice by JEA; provided, that the date of the termination shall not be more than fifteen days later than the date of the request. In case the notice is not given, the user shall continue to be liable for service provided thereafter and for the minimum monthly rate or charge in case no water is consumed, even though the customer may vacate the premises or the premises may be occupied by other parties who fail to make application for service.
5. All non-domestic users of the JEA sanitary sewer system shall complete and submit the *JEA Commercial/Industrial Questionnaire*. Information supplied in the questionnaire will be used to determine if the business is required to apply for an Industrial User Discharge Permit. The questionnaire is found in Appendix C. Regulatory requirements for JEA's Industrial Pretreatment Program can be found at <http://www.jea.com/business/services/industrialpre/index.asp>.

(This page left blank.)

Chapter V Penalties and Liability

(This page left blank.)

5.01 Damaging, destroying facilities prohibited

No person shall maliciously or willfully damage or destroy or uncover a part of the sewer or water system of the city. Violation of this section shall constitute a class D offense.

5.02 Failure to Comply with Notice to Correct

A person violating a provision of this document shall be guilty of a class “D” offense. Each day on which a violation continues shall be deemed a separate class D offense. Nonpayment of delinquent sewer or water service charges shall not be an offense against the city.

5.03 Liability for Damages Caused by Violations

A person violating a provision of this document shall become liable to JEA for expense, loss or damage incurred by JEA by reason of the violation.

(This page left blank.)

Forms

(This page left blank.)

(This page left blank.)

Appendix A.
Rules and Regulations for Reclaimed Water

(This page left blank.)

A-1.01 Introduction

We are fortunate in Northeast Florida to have a clean and relatively abundant source of water – the Floridan Aquifer. In addition to actively promoting water conservation, JEA is looking for a way to use less potable water. One solution is to utilize Reclaimed Water instead of drawing more water out of the aquifer. Reclaimed water is a safe alternative for irrigation and other non-potable water needs. Because of the nature and origin of reclaimed water, the Florida Department of Environmental Protection has promulgated rules and regulations governing reclaimed water programs. JEA’s reclaimed water program complies with those rules and regulations as set forth in Chapter 62-610, Florida Administrative Code (FAC), and Chapter 62-555 FAC., and others.

A-1.02 Intent

It is the intent of JEA to make reclaimed water available for irrigation purposes and other authorized non-potable uses. Reclaimed Water will be available in certain areas of JEA’s Utility Service Area where it is determined that the construction of a reclaimed water transmission/distribution system is necessary, practical, and beneficial to JEA’s Reuse Service Area. The reclaimed water system shall be expanded to provide service to the Reuse Service Area as determined by JEA.

A-1.03 Purpose

It is the purpose of this document to promote the public health, safety, and welfare by the establishment of a Reclaimed Water Use Program, by regulating the construction of reclaimed water transmission/distribution systems determined to be necessary and beneficial, and by governing the use of reclaimed water.

A-1.04 Applicability

The provisions of this document shall apply to certain areas of JEA’s service area where it is determined that the construction of a reclaimed water system is practical, necessary, and beneficial. The reclaimed water distribution systems shall be approved to provide service to designated areas determined by JEA.

A-2.01 Authority to Adopt Rules and Regulations

The Board shall have the authority to establish reasonable rules and regulations concerning the use of reclaimed water, or to amend existing rules and regulations to remain in compliance with applicable State and federal regulations.

A-2.02 Authority to Adopt Rates, Fees, and Charges

The Board shall have the authority to establish rates, fees, and charges for the reclaimed water service and to provide terms and conditions for the payment and collection of them.

A-3 Connections to Reclaimed Water System

A-3.01 Availability of Service

Availability of service shall be determined by JEA Water /Wastewater System Planning. Reclaimed water service will not be provided to any residential customer that does not have an active potable water source in place. A developer or other interested person may request information from JEA’s Water /Wastewater System Planning. Reclaimed water service is deemed available to the owner, tenant or occupant of each lot or parcel of land that is either 1) Located within JEA’s Reuse Service Area and/or 2) Abuts upon a street, lot or other public way or place containing such system.

A-3.02 Requirements to Connect to Reclaimed Water System

For new Development, where the distance from the reclaimed water distribution system and the property line is less than or equal to the distances set out in Table 1 below, the owner shall connect the premises or cause the premises to be connected with the reclaimed water distribution system. Where the distance from the reclaimed water distribution system and the property lines is more than the distances in Table 1, the owner shall include reclaimed water distribution mains within their development for future connection to the system by JEA.

Table 1

A)

ERC*	Max. Distance from the Residential Development Property Line to the Reclaimed Water Facility in Feet
<5	Abuts
5 - 14	50
15 - 34	125
35 – 71	250
72 - 142	500
143 - 286	1000
287 - 500	2000
>500	4000

JEA Rules and Regulations for Water, Sewer, & Reclaimed Services
Appendix A. Rules and Regulations for Reclaimed Water

*ERC – Equivalent Residential Customer

B)

Area Available for Irrigation (acres)	Max. Distance from the Multi-Family, Commercial and Industrial Development Property Line to the Reclaimed Water Facility in Feet
---------------------------------------	--

<1	Abuts
1 - 2	50
3 - 5	150
6 - 12	300
13 - 25	600
>25	1350

It shall be unlawful to connect to JEA potable water system for irrigation purposes after reclaimed water becomes available. Customers with existing irrigation wells shall be required to connect their irrigation system to the reclaimed water system must first physically disconnect the irrigation system from the existing irrigation well and provide evidence of an air gap separation between the well and the irrigation system.

1. Low Pressure System

- (a) It will be required to have a reduced pressure backflow prevention assemblies (RP) installed on the domestic service prior to the installation of the reclaimed meter.
- (b) It will be required for the customer to supply electric service (120volts/30amps) at the point of connection for JEA’s reclaimed water delivery station.
- (c) It will be required that all connection to the low pressure system discharge into an open storage facility. (E.g. pond, storage tank, etc...)
- (d) Applicant must have a written letter of availability from JEA’s Planning Department; signed agreement from JEA’s Customer Sales & Service; and make application for connection with payment for the Delivery Station to JEA’s Pre-service.

- (e) Industrial sites will have JEA approved backflow prevention devices on the reclaimed water service line, where necessary, in accordance with Rule 62-610.660, F.A.C.

2. Pressurized System

- (a) It will be required to have a double check valve assemblies (DCVA) installed on the potable service prior to the installation of the reclaimed meter.
- (b) The in-ground irrigation system must be installed before a reclaimed water meter will be installed. This is to allow for the Cross Connection Inspection to be completed at the time of connection.
- (c) It is preferred that all irrigation systems connected to the reclaimed water system have outside controls accessible to JEA for routine Cross-Connection Inspection. No hose bibs or other hand operated devices will be allowed. Exceptions may be made on commercial applications to have hose bibs installed; they must be approved by JEA prior to installation and must be in accordance with Rule 62-610.469(3), F.A.C.
- (d) Industrial sites will have JEA approved backflow prevention devices on the reclaimed water service line, where necessary, in accordance with Rule 62-610.660, F.A.C.

A-3.03 Application for Connection to System

Customers in designated Reuse areas may connect to the reclaimed water system when service is deemed available by JEA. Compliance with this document in no way relieves the property owner or users from the responsibility for obtaining and fulfilling the requirements of construction or other permits required by and issued by agencies other than JEA.

Application for connection to the reclaimed water system shall be made to JEA on the form provided for that purpose. Capacity, service, meter and inspection fees as established by the Board shall be paid to JEA at the time the application for service is filed.

All fees are in accordance with JEA's rates and tariffs.

A-3.04 Limitations of use Reclaimed Water

1. Use of reclaimed water shall be limited to irrigation of residential lawns, golf courses, common areas, landscaped areas, highway medians, rights-of-way, cooling towers, and other uses specifically approved by JEA and allowed under Chapter 62-610, FAC.
2. Reclaimed water shall not be used inside any residential dwelling, or to fill swimming pools, hot tubs, spas, wading pools or other open waters where human contact or immersion may occur. Except when permitted to fill a storage pond and meets the advisory sign specification set forth in Part A-4.05 of this document.
3. Reclaimed water shall not be applied to areas within 100 feet of any public outdoor eating, drinking, or bathing facility, unless aerosol formation is minimized.

A-3.05 Discontinuance of Service by JEA

JEA may discontinue reclaimed water service to any customer due to a violation of the provisions of this document or other Federal, State, or Local regulations, for non-payment

of bills, for tampering with any service, for plumbing cross-connections with another water source, for acts detrimental to the system, or for the convenience of JEA. JEA has the right to cease service until the condition is corrected and all costs due JEA are paid. These costs may include delinquent billings and payment for any damage caused to the system. Should discontinued service be reconnected without authorization, then JEA shall remove the service and make such additional charges as are established by the Board.

A-4 Installation/Construction Requirements for Reclaimed Water Irrigation Systems

A-4.01 General

1. All construction of reclaimed water facilities shall be in conformance with JEA Materials and Construction Standards and the appropriate County and State requirements.
2. Wells connected to existing irrigation systems shall be disconnected prior to connection to the reclaimed water system.
3. Existing irrigation systems shall be disconnected from potable water systems prior to connection to the reclaimed water system.
4. Irrigation systems for single-family residential customers shall be in-ground irrigation systems. Hose bibs or other hand operated irrigation devices shall not be present on single-family residential irrigation systems connected to the reclaimed water system.

5. Reuse meter and valves boxes shall be of the size and design required by JEA and shall meet the labeling specifications as set forth in Part A-4.04 of this document.
6. All irrigation systems connected to the reclaimed system will have outside controls accessible to JEA for routine Cross-Connection Inspection.

A-4.02 Public Easement and Rights-of-way

No reclaimed water facilities will be accepted by JEA unless they are installed in a dedicated public right-of-way or JEA approved easement. All new easements shall be adequately sized to accommodate construction and maintenance of any new reuse system component.

A-4.03 Backflow Prevention Devices (BPD)

An approved BPD shall be installed and maintained at the property owner's or customer's expense, on the potable water supply where Reclaimed Water is available. Industrial sites will have JEA approved backflow prevention devices on the reclaimed water service line, where necessary, in accordance with Rule 62-610.660, F.A.C. For appropriate BPD type refer to JEA's Cross Connection Control (CCC).

A-4.04 Color-Coding and Tagging

All reclaimed water valves and outlets shall be appropriately tagged or labeled, bearing the words in English and Spanish: "Do Not Drink," together with the equivalent standard international symbol to warn the public and employees that the water is not intended for drinking.

All piping, pipelines, valves, sprinkler heads, and outlets shall be color coded using pantone purple 522c, or otherwise marked, to differentiate reclaimed water from potable or other water. Individual residential service connections shall consist of a lockable curb-stop connection and shall be located in a meter box, typically on the opposite property corner from the potable water service connection.

Underground piping that is not manufactured of metal or concrete shall be color-coded for reclaimed water transmission/distribution systems using Pantone Purple 522C using light stable colorants. Underground metal and concrete pipe shall be color-coded or marked using purple as a prominent color. If tape is used to mark the pipe, the tape shall be permanently affixed to the top and each side of the pipe, three locations parallel to the axis of the pipe. For pipes less than 24 inches in diameter, a single tape may be used along the top of the pipe. Visible, above ground portions of the reclaimed water transmission/distribution system shall be clearly color-coded or marked using purple as a prominent color.

It is required, that all reclaimed water irrigation systems be constructed using purple pipe and purple sprinkler heads. This recommendation is to reduce the risk of cross-connection between reclaim water and potable water on the customer's property.

Customers with existing irrigation systems prior to reclaimed water being deemed available will not be required to retrofit the irrigation system, but will be required to upgrade the system when improvements and/or expansions are made.

A-4.05 Advisory Signs

The public shall be notified of the use of reclaimed water by the customer. Non-residential customers shall be required to post and maintain advisory signs designating the nature of the reuse project. Advisory signs shall include the following text in English and Spanish: "Do Not Drink", together with the equivalent standard international symbol, and shall use purple as a prominent color. It is recommended that all advisory signs be 18" by 18" in size and constructed of metal. All advisory signs and sign plans will need prior approval by JEA before being installed. Sign plans shall be submitted to JEA's Environmental Services for approval. Advisory signs shall be unobstructed, visible to the public and posted at the following locations:

1. Adjacent to lakes or ponds used to store reclaimed water not located at the wastewater treatment facility, including golf course irrigation ponds and any subsequent downstream, interconnected ponds. Advisory signs shall be posted in areas accessible to the public and not more than 300 feet apart. Advisory signs posted adjacent to ponds, shall include the following text in English and Spanish: "Do Not Drink," and "Do Not Swim," together with the equivalent international symbols;
2. At the Entrance, 1st, and 10th tees of golf courses and recommended to be indicated on the score card;
3. Adjacent to decorative water features using reclaimed water, such as waterfalls or fountains. Advisory signs posted adjacent to decorative water features shall include the following text in English and Spanish: "Do Not Drink," and "Do Not Swim," together with the equivalent international symbols;
4. At each entrance to residential neighborhoods, businesses, and common use areas using reclaimed water;
5. Along medians and rights-of-way where reclaimed water is used that are located outside residential neighborhoods. Sign must be visible in both directions and not more than 1000 feet apart, unless approved by JEA.

A-5 Cross Connection Control

In all premises where reclaimed water service is provided, the public or private potable water supply shall be protected by an approved cross-connection control assembly in accordance with JEA's Cross Connection Control Program (CCCP). All devices and material installed for cross-connection control must be approved by JEA. Where any cross-connection is found, it shall be discontinued. Before reconnection of that service, the public potable water system shall be protected against possibility of future cross-connections, and additional devices may be required as specified by JEA and installed at the customer's expense.

A-6 Inspections

Pursuant to Chapter 62-610.469 (7)(h), FAC, in order to verify proper connections, monitor proper use of reclaimed water, and minimize the potential for cross-connections, JEA will inspect the customer's irrigation system at the time of connection or reconnection to the reclaimed water system and periodically thereafter, as specified in the Appendix B Cross Connection Control Policy.

A-7 Setback Distances

1. A setback distance of 100 feet from any outdoor public eating, drinking, bathing, or swimming facilities shall be maintained.
2. A setback distance of 75 feet from any potable water well shall be maintained.

A-8 Responsibilities for Ownership and Maintenance of Reclaimed Water System

A-8.01 JEA Responsibilities

1. JEA shall own and maintain all reclaimed water transmission and distribution systems within the public right-of-way and public easements.
2. JEA will make a reasonable effort to inspect and maintain its reclaimed water system in good repair, but assumes no liability for any damage caused by the system that is beyond the control of normal maintenance.
3. Production of reclaimed water is a function of wastewater treatment facility operational criteria and is controlled by JEA. JEA reserves the right to limit availability during certain hours, to temporarily shut off the system without notice for repairs, maintenance or operational reasons, and to limit supply quantities. Reclaimed water supplies and pressure are not guaranteed.
4. JEA shall own and operate the reclaimed water delivery station for bulk customers and all reclaimed water meters for commercial and residential customers.
5. To provide annual customer education in accordance with rule 62-610, F.A.C.

A-8.02 Customer Responsibilities

1. The property owner and/or customer shall be responsible for maintenance of the irrigation system.
2. The property owner and/or customer shall be responsible the backflow device on their property downstream (customer side) from the potable water service connection.
3. The property owner and/or customer shall be responsible for the operation of their reclaimed water irrigation system to prevent ponding or run-off from the irrigated area.
4. The property owner and/or customer shall be responsible for the maintenance of all irrigation lines and appurtenances on the property served by JEA. JEA reserves the right to disconnect the service to any property when the irrigation system and appurtenances are not properly maintained. In addition, should the customer require reclaimed water at different pressures, or different quality, or in any way different from that normally supplied by JEA, the owner and/or customer shall be responsible for the necessary devices to make these adjustments and for obtaining approval by JEA.
5. The property owner and/or customer shall be responsible to notify JEA of any overflows of storage ponds and/or tanks, etc. as soon as possible of first knowledge of the overflow. This is intended to include leaking, broken pipes etc.
6. The property owner and/or customer shall be responsible to provide JEA unobstructed access easement to any Delivery Stations and/or Meters installed at that premise.
7. Where Reclaimed Water is supplied to a storage facility the property owner and/or customer shall be responsible to maintain and treat the storage facility.
8. The property owner and/or customer shall be responsible for the installation of all advisory signs required in section A4.05 of this document.
9. The property owner and/or customer shall be responsible to comply with all Federal, State, and local laws and/or requirements.

A-9 Testing of Backflow Assemblies

It shall be the duty of the property owner and/or customer at any premises where backflow prevention assemblies are installed to have thorough inspections and operational tests made at least once a year, or more often in those instances where inspections indicate a need. These inspections and tests shall be at the expense of the property owner and/or customer and be performed by the assembly manufacturers' representative, or by a backflow assembly technician retained by the property owner and/or customer. In all cases, testing will be conducted by a certified backflow assembly tester. JEA will notify the property owner and/or customer when tests are required, supply the necessary test forms and instructions. The forms shall be completed and returned to JEA by the date indicated on the form to avoid disconnection of service. For more information on backflow testing and installation, refer to JEA's Cross-Connection Control Program (CCCP).

A-10 Penalties for Non-Compliance

A-10.01 Termination of Service

Upon discovery of any cross-connection JEA shall cause the Reclaimed water service to premises to be terminated. A written notification detailing all cross-connections found during the inspection will be sent to the owner or authorized agent of the owner of the building or premises, stating that corrections must be made and setting a reasonable time for compliance.

JEA shall cause discontinuance of Potable water service if a required backflow prevention assembly has been bypassed or failed to be tested or properly maintained as required by these rules and regulations and JEA's CCCP. JEA shall also cause discontinuance of Potable water service if an air-gap separation system is compromised. If the posting of advisory signs are not in compliance with 62-610.468 (FAC) or part A-4.05 of this document, JEA shall cause the Reclaimed water service to premises to be terminated.

If property owner and/or customer violate any provision of the service agreement, Federal, and State requirements, JEA shall cause the Reclaimed water service to premises to be terminated.

A-10.02 Monetary Penalties

When evidence exists of tampering with or, of damage to meters or associated equipment by the customer, the customer is subject to prosecution, adjustment of bills, and reimbursement to JEA for expenses as defined in Management Directive 515.

Violations of provisions concerning cross-connections within the City/County Building Code may constitute a class "D" infraction. When evidence exists of a cross-connection by the customer, the customer may be held responsible to reimburse JEA for all cost incurred in correcting and mitigating the cross-connection.

A-11 Pertinent Sections of Local Codes

A-11.01 City building Code - Chapter 341

(Construction Regulations and Building Codes)

Chapter 341 (Plumbing Code)

Section 1. Section 341.101, Ordinance Code is amended in part to read as follows:

Adoption of Florida Building Code 2001 as the Plumbing Code for the City of Jacksonville.

Forms

(This page left blank.)

Appendix B.
Cross-Connection Control Program

(This page left blank.)

Policy on Cross-Connections

JEA agrees with the American Water Works Association's (AWWA) statement issued on cross-connection and it is as follows:

The American Water Works Association (AWWA) recognizes water purveyors have the responsibility to supply potable water to their customers. In the exercise of this responsibility, water purveyors or other responsible authorities must implement, administer and maintain ongoing backflow prevention and cross-connection control programs to protect public water systems from the hazards originating on the premises of their customers and from temporary connections that may impair or alter the water in the public water systems. The return of any water to the public water system after the water has been used for any purpose on the customer's premises or within the customer's piping system is unacceptable and opposed by AWWA.

The water purveyor shall assure that effective backflow prevention measures, commensurate with the degree of hazard, are implemented to ensure continual protection of the water in the public water distribution system. Customers, together with other authorities, are responsible for preventing contamination of the private plumbing system under their control and the associated protection of the public water system.

A statement adopted by Board of Directors of the American Water Works Association on Jan. 26, 1970, revised June 24, 1979 and reaffirmed June 10, 1984 and revised Jan, 28, 1990 and Jan. 21, 2001, reaffirmed Jan. 16, 2005; and, revised Jan. 17, 2010.

Introduction

A cross-connection is defined in the rules of the Department of Environmental Protection (DEP), of the State of Florida, Chapter 62-550 of the Florida Administrative Code (FAC) as "Any physical arrangement whereby a public water supply is connected, directly or indirectly with any other water supply system, sewer, drain, conduit, pool, storage reservoir, plumbing fixture, or other device which contains or may contain contaminated water, sewage and other waste or liquid of unknown or unsafe quality which may be capable of imparting contamination to the public water supply as the result of backflow. By-pass arrangements, jumper connections, removable sections, swivel or changeable devices and other temporary or permanent devices through which or because of which backflow could occur are considered to be cross-connections." Consequently, either cross-connection or the chance of backflow must be eliminated to prevent degrading the high quality of water that water purveyors strive to maintain.

Initially, the primary responsibility for safeguarding water quality on private property and eliminating cross connections and preventing backflow, was left to local health agencies and building and inspection departments. Then, beginning with the Safe Drinking Water Act, signed by President Ford on Dec. 16, 1974, a chain of laws and regulation evolved that resulted in the State requirement (Florida Safe Drinking Water Act, Sections 403.850-403.864, Florida Statutes) for all the public water systems to have a cross-connection control program contained within the Rules of Department of Environmental Protection (DEP), Chapter 62-555, FAC, State of Florida, on Jan. 3, 1991, amended Aug. 28, 2003, adopted the following policy:

Community water systems shall establish a routine cross-connection program for the purpose of detecting and preventing cross-connections that create an imminent and substantial danger to the public health by and from contamination due to the cross-connection. Upon discovery of a prohibited cross-connection, both community and non-community water systems shall either eliminate the cross-connection by installation of an appropriate backflow prevention device acceptable to the Department (DEP) or discontinue service until the contaminate source is eliminated, Chapter 62-555.360(3), FAC.

This statement was later updated to include that "Such program shall be developed utilizing accepted practices of the American Water Works Association guidelines as set forth in AWWA manual M14, "Recommended Practice for Backflow Prevention and Cross-Connection Control, 3rd Edition." In compliance with this mandate, the following is JEA's Policy on Cross-Connection Control.

We urge you to acquaint yourself with the policies and information presented in this manual. It is only through the education and commitment of persons like yourself that we can control the hazards presented by cross connections within our public drinking water supply. JEA stands behind this policy and its enforcement and will offer its assistance to all who share the responsibility of safe water.

B-1 Overview

B-1.01 Purpose

The purpose of this Policy is to protect JEA's public potable water supply from the possibility of contamination. This policy is to promote the elimination or control of existing cross-connections, actual or potential, between its customers' in-plant plumbing fixtures and industrial piping and the public water supply; and to provide for the maintenance of a continuing program of cross-connection control that will systematic and effectively prevent the contamination of the potable water distribution system. More exactly, the Policy is intended to prevent delivered water (water that has passed beyond the public water system and into the private distribution systems of consumers) from re-entering the public distribution system and being subsequently delivered to consumers. This allows persons active in piping design and installation to incorporate and install appropriate backflow prevention assemblies correctly.

B-1.02 Causes of Backflow

The causes of backflow are not usually eliminated completely since backflow is often initiated by accident or unexpected circumstances. However, some causes of backflow can be partially controlled by good design and informed maintenance. Listed below are the major causes of backflow as outlined under the two types: backsiphonage and backpressure.

1. **Backsiphonage** - is caused by reduced or negative pressure being created in the supply piping. The principal causes of backsiphonage are:
 - a) Line repair or break lower than a service point. This will allow negative pressures to be created by water trying to flow to a lower point in the system.
 - b) Undersized piping - if water is withdrawn from a pipe at a very high velocity, the pressure in the pipe is reduced and the pressure differential created can cause water to flow into the pipe from a contaminated source.
 - c) Lowered pressure in water main due to high water withdrawal rate such as fire fighting, water main flushing, or water main breaks.
 - d) Reduced main pressure on suction side of a booster pump.
2. **Backpressure** - may cause backflow to occur where a potable water system is connected to a non-potable system of piping, and the pressure in the non-potable system exceeds that in the potable system. The principal causes of back pressure are:
 - a) Booster pump systems designed without backflow prevention assemblies.
 - b) Potable water connections to boilers and other pressure systems without backflow prevention assemblies.
 - c) Connections with another system which may at times have a higher pressure.

- d) Water stored in tanks or plumbing systems which, by virtue of their elevation, would create head sufficient to cause backflow if pressure were lowered in the public system.

B-2 Responsibilities

B-2.01 Cross-Connection Control Program

The responsibilities of JEA's cross-connection control program in accordance with State Law Chapter 62-555, FAC are as follows:

1. To protect JEA's public water supply from the possibility of contamination by isolating within its consumers' private water systems, contaminants or pollutants which could, under adverse conditions, backflow through uncontrolled cross-connections into the public water system.
2. To eliminate or control existing cross-connections, actual or potential, between the consumer on site potable water system(s) (i.e. well) and non-potable water system(s) plumbing fixtures, and industrial piping systems.
3. To provide a continuing inspection program, of cross-connection control, which will systematically and effectively control all actual or potential cross-connecting which may be installed in the future.

B-2.02 Customers

The customers' responsibility starts at the point of delivery from the public potable water system and includes all of their water systems. The customer, at their own expense, shall install, operate, test and maintain approved backflow prevention assemblies, as directed by JEA. The customer shall maintain accurate records of tests and repairs made to backflow prevention assemblies and provide JEA with copies of such records. The records shall be on forms approved by JEA.

In event of accidental pollution or contamination of the public or consumers' potable water system due to backflow on or from customer's premises, the owner shall promptly take steps to confine further spread of pollution or contamination within the customers' premises, and shall immediately notify JEA of the hazard.

B-2.03 Backflow Prevention Assembly Installers

Installation of backflow preventers shall be by certified plumbers and requires a permit through the City of Jacksonville Plumbing Inspection Division. Backflow preventer installation shall be in accordance with the manufacturers' installation instructions and any additional instructions approved by JEA. All backflow preventers shall be installed adjacent to the right-of-way on private property within 10 feet of the water meter, unless approved by JEA.

Regarding residential irrigation (potable water) backflow preventers, backflow preventer installation may be at an alternate accessible location closer to the customer residence upon execution of the "JEA Residential Irrigation Customer Affidavit Form", attached to this Appendix. The customer affidavit form shall attest that there are no additional connections between the residential irrigation meter and the backflow preventer. For all other backflow preventer locations, including backflow preventers required in residential reclaimed water service areas, backflow preventers

shall be located adjacent to the right-of-way on private property within 10 feet of the water meter, unless approved by JEA.

B-3 Inspections

B-3.01 Frequency

JEA shall have free access to the premises of any user of its water supply for the purpose of inspecting, and/or testing the backflow devices installed or to inspect the premises to determine if there are any cross-connections. Devices shall be installed so that they are easily accessible for inspection, testing, maintenance and repair.

For premises where reclaimed water is available JEA will perform site inspections. These inspections will be on the customer's premises and will consist of, but are not limited to:

1. Notifying customer of site inspection
2. Checking Irrigation system for excess runoff
3. Visual check for Cross-connection
4. Test potable water for signs of reclaimed water
5. Verify backflow device is installed and has current certification
6. Physical check of all outside hose connections

The initial inspections will be performed by JEA when the reclaimed water meter is installed and connected to the irrigation system. The periodic inspection will be performed by JEA every two years. JEA will also perform site inspection when the reclaimed service is cut on in a new customer's name or when the service status changes to active.

B-3.02 Proposed Constructions

All new construction plans and specifications for commercial facilities shall be reviewed by JEA to determine the degree of potential cross-connection hazard. At this time, backflow prevention requirements in accordance with this policy will be made.

B-3.03 New and Existing Facilities

To determine the degree of hazard to the public potable water system, a survey will be made of the consumers' presently installed water system. This survey need not be a detailed inspection of the location or disposition of the water mains but can be confined to establishing the water uses on the premises for the existence of cross-connections, and the availability of auxiliary or used water supplies. On-site inspections are made of new and existing facilities and should any devices or plumbing change be required, a follow-up inspection will be made of the same facilities at a later date.

B-4 Cross-Connection Hazards and Required Protections

B – 4.01 Facilities - Type of Backflow Protection Required

JEA Rules and Regulations for Water, Sewer, & Reclaimed Services
Appendix B. Cross-Connection Control

In most cases, a cross-connection to the public water supply is eliminated by the presence of an approved backflow preventer. The following details the types of backflow prevention required on commercial, residential and fire service water lines. This list is presented as a guideline and should not be construed as being complete. Abbreviations used are as follows:

- AG - Air Gap Separation- B-8.01
- RP - Reduced Pressure Backflow Assembly –B-8.04
- RPDA - Reduced Pressure Detector Assembly–B-8.04
- DCDA – Double Check Detector Assembly – B-8.03
- DCVA or DC- Double Check Valve Assembly – B-8.02
- RDC – Residential Dual Check – B-8.05

Commercial Facilities –

Since before 1990, the Building Inspection Division has required the installation of backflow preventers on all new commercial water service lines. JEA supports this policy and requires backflow preventers to be maintained on all commercial facilities built since 1990. Commercial facilities built prior to 1990 that present a hazard to the public water system must also maintain a backflow preventer. Unless otherwise authorized, commercial facilities must maintain a reduced pressure backflow preventer on their water service lines. The following tables provides examples of facilities presenting a hazard to the water system and the required backflow preventer.

TYPE OF FACILITY	MINIMUM TYPE OF PROTECTION
Apartments with fire hydrants, blow offs, pools, or irrigation systems	AG at pool or RP
Automobile Service Centers	RP
Beverage Plant or Bottling Plant	RP
Breweries, Distilleries	RP.
Car Wash with recycling system and/or Wax Inductor	RP
Chemical Plants	RP
Chemical or petroleum storage facilities	RP
Commercial services where reclaimed water is available	RP
Commercial services with an auxiliary water system connected or not connected to public water system	RP
Commercial services using a steam boiler, cooling system, or hot water heating system where chemical water conditioners are used	RP
Commercial services utilizing a water storage tank, reservoir, pond, or similar appurtenance as a water supply.	RP

JEA Rules and Regulations for Water, Sewer, & Reclaimed Services
Appendix B. Cross-Connection Control

Commercial services with submerged water supply inlets.	RP
Dairies	AG or RP
Dentist or Doctors Office	RP
Exterminating Company (Pesticides) ²	AG or RP
Fertilizer Plants	RP
Film Laboratory or Processing Plant	RP
Hospitals, Clinics, Medical Facilities	RP (Parallel)
Hotels and Motels	RP
Irrigation Systems with elevated or pop-up sprinkler heads	RP
Irrigation Systems with chemical injectors	RP
Laundries, Dry Cleaning, or Dye Works	RP
Laundromats	RP
Machine Tool Plants	RP
Master Metered Strip Shops	RP
Metal Plating Plant	RP
TYPE OF FACILITY	MINIMUM TYPE OF PROTECTION
Mobile Home/Travel Trailer Parks with fire hydrants, blow offs, pools, or irrigation systems.	RP
Morgues or Mortuaries	RP
Nursing Homes	RP
Packing Houses or Rendering Plants	RP
Paper Products Plant	RP
Parks/Recreational Facilities	RP
Petroleum Processing Plant	RP
Petroleum Storage Plant	RP
Pharmaceutical or Cosmetic Plant	RP
Piers, Docks or Waterfront Facilities	RP
Power Plants	RP
Radioactive Material Plants	RP
Restaurants / Food Service Establishments	RP

JEA Rules and Regulations for Water, Sewer, & Reclaimed Services
Appendix B. Cross-Connection Control

Sand and Gravel Plants	RP
Schools	RP
Swimming Pools with Piped Fill Line	AG at pool or RP
Sewage Treatment Plants	RP
Sewage Pumping Stations	RP
Storm Water Pumping	RP
Tall Buildings over three stories	RP
Veterinary Establishments	RP

¹ Refer to Appendix A. Reclaimed Water for more information on Reclaimed Water.

²Exterminating Companies-All tanks, tank trucks, and spraying apparatus used to convey pesticides in an exterminating process are required to use only designated-protected potable water fill locations. Filling with potable water at unspecified locations or private residences is prohibited. All filling locations will consist of overhead piping arrangements with correctly installed air-gap. If, for any reason, an overhead piping arrangement cannot be used, a reduced pressure zone backflow assembly must be installed on the fill line. All filling locations must be approved by JEA.

An approved backflow preventer of the type designated shall be installed on each residential water service connection to any premises containing the following real or potential hazards.

MINIMUM TYPE OF PROTECTION (RESIDENTIAL SERVICE CONNECTIONS)	
Premises utilizing an auxiliary water system (well, pond, or other system connected or not connected to the public water system).	RP
Premises utilizing a solar hot water system with chemical addition.	RP
Premises with swimming pools with piped fill line.	AG or RP
Premises with piped fill lines for fountains.	AG or RP
Premises utilizing in-ground irrigation systems.	DCVA ³ ,RP ⁴
Premises that have reclaimed water available for irrigation or other uses. ¹	DCVA,RP,RDC ²

¹ Refer to Appendix A. Reclaimed Water for more information on Reclaimed Water.

² Refer to Section B-4.02 for conditions allowing the use of RDC devices.

³ DCVA allowed if the residential irrigation service connection was made prior to May 2014 and there is no chemical feed system.

⁴ RP required if backpressure may exist, if a pump is utilized, or if chemicals are added to the irrigation system. RP is allowable in lieu of DCVA.

B-4.02 Residential Premises with a Reclaimed Water System

For residential premises serviced with reclaimed water, any one of the three options below is available.

1. Reduced-Pressure Principle Assembly (RP)¹
2. Double Check Valve Assembly (DCVA)¹
3. Residential Dual Check (RDC) device² plus any ***one*** of the following measures:
 - a. Customer Agreement³
 - b. Managed Properties⁴

According to Florida Plumbing code, installation of a backflow preventer on the domestic water line necessitates the installation of an expansion tank on the home's hot water tank.

Notes:

¹All residential RPs and DCVAs must be tested once every two years.

²Upon installation of a RDC, a certification of installation must be submitted to JEA. Dual check devices must be replaced at least every five years.

³Customer Agreements: The customer shall sign an agreement provided by JEA that prohibits the customer from cross-connecting the customer's reclaimed water system to the customer's potable water system. Failure to abide by the agreement will result in discontinuation of service. Service may be restored once the cross connection is eliminated and a residential dual check device is replaced by a reduced pressure backflow preventer.

⁴Managed Property: Managed properties are those under the jurisdictional control of a third-party with established restrictions on the use/modification of the properties such that the customer is prohibited from altering/tampering with the property's potable water system and auxiliary or reclaimed water system. The third-party's legal instrument establishing the restrictions shall be reviewed and kept on file by JEA.

B-4.03 Installations Requiring Continuous Service: Parallel Installation

All non-residential backflow prevention assemblies with test cocks are required to be tested with a minimum frequency of once per year. Testing requires a water shutdown usually lasting five (5) to twenty (20) minutes. For facilities that require an uninterrupted supply of water, and when it is not possible to provide water service from two separate meters, provisions shall be made for a "parallel installation" of backflow preventer.

Multi-story buildings that have a number of flush-o-meter toilets should be equipped with parallel assemblies. Experience has shown if the water supply is shut off to this type of building, flush-o-meters may have to be manually reset. During testing, one assembly is left on while the other is being tested. Usually the two assemblies are sized one device size smaller than the service line, e.g. one 2-inch device or two 1½-inch devices, one 8-inch device or two 6-inch devices. JEA will not accept an unprotected bypass around a backflow assembly when the assembly is in need of testing, repair, or replacement.

B-4.04 Type of Backflow Protection Required - Fire Protection Services

An approved backflow preventer of the type designated shall be installed on each fire protection service to any premises where the fire protection system contains any of the following components unless JEA determines that there is no real or potential hazard to the public water system. The following are typical:

JEA Rules and Regulations for Water, Sewer, & Reclaimed Services
Appendix B. Cross-Connection Control

MINIMUM PROTECTION		
Metered Service	Unmetered Service	
DC	DCDA	None of the following are present: booster pumping; connection to auxiliary water supply or chemical feeds
RP	RPDA	Any of the following are present: booster pumping; connection to auxiliary water supply or chemical feeds

B-4.05 Other Cross-Connection Hazards

1. **Fixture Inlets (or Valved Outlets)** with hose attachments, which may constitute a cross-connection, shall be protected by the proper approved vacuum breaker (AVB, HBVB, etc.) installed at least six (6) inches above the highest point of usage and located on the discharge side of the last valve. Fixtures with an integral vacuum breaker, manufactured as a unit may be installed in accordance with their approved requirements.
2. **Air condition Cooling Tower** - Potable water inlet shall have a reduced pressure zone backflow assembly attached.
3. **Aspirators and Ejectors** - Shall have an AVB or PVB, depending upon the degree of hazard, on the faucet from which these devices are attached or operated.
4. **Booster Pumps** - Shall not be interconnected unless the public supply is protected by an RP at the service connection, and approval is given by JEA.
5. **Private Wells** - Shall not be interconnected unless the public supply is protected by an RP at the service connection, and approval is given by JEA.
6. **Portable Spray and Cleaning Equipment** - Any portable pressure spray or cleaning units that have the capability of connecting to any potable water supply and do not contain a built-in approved air gap, should be fitted with a reduced pressure backflow assembly.
7. **Miscellaneous uses of Water from Fire Hydrants** - The operation of fire hydrants by other than authorized personnel is prohibited. The department may permit the use of water from a hydrant for construction or other purposes provided the applicant shall properly apply for and adhere to the backflow requirements on a hydrant permit. Any backflow devices used on a fire hydrant shall be tested and recertified every 6 months.
8. **Vacuum Breakers** (vacuum relief valves) designed to prevent collapse or implosion of a heated pressure vessel when being cooled are not acceptable devices for protection against backflow in potable water line.

Note: Any device, equipment, or situation not covered by this cross-connection policy that may constitute a potential health hazard will be examined for appropriate treatment by JEA's authorized agent.

Note: Single-check valves will not be accepted as a means of protecting the potable drinking water and therefore may only be used to prevent backflow which would affect the functioning of a plumbing system, such as to prevent recirculation of potable hot water. Where single-check valves are improperly used, they will be required to be replaced by an appropriate approved backflow prevention assembly.

B-5 Testing of Backflow Preventers

It shall be the duty of the customer-user at any premises where a testable device is installed, to have thorough inspections and operational tests made at a frequency equal to or greater than the minimum frequencies stipulated by JEA for each customer category. The minimum testing frequency for non-residential backflow preventers is once every year. The minimum testing frequency for residential backflow preventers is once every two years. If inspections warrant, JEA may require the customer-user to test backflow preventers on a more frequent basis. These inspections and tests shall be at the expense of the water user and be performed by the assembly manufacturers' representative, by JEA personnel, or by a certified device technician. The water purveyor will notify the customer-user when tests are required. A passed test result report will be completed and submitted to JEA by the required date. JEA will supply the necessary test forms and instructions. The following data is required to be able to update the customer's record:

1. Service address and ZIP code where the device is located
2. Owner and JEA account number
3. Description of device's location and meter number
4. Date of installation
5. Type of device
6. Manufacturer
7. Model number
8. Serial number

B-6 Penalties for Non-Compliance

B-6.01 Termination of Service

A written notification detailing all cross-connections found during the inspection will be sent to the owner or authorized agent of the owner of the building or premises, stating that corrections must be made and setting a reasonable time for compliance. Upon failure of the owner or authorized agent of the owner of the building or premises to have defect(s) corrected by the specified time, the water purveyor shall cause the water service to the building or premises to be terminated.

The water purveyor shall cause discontinuance of water service if a required backflow prevention assembly has been bypassed or failed to be tested or properly maintained as required by this policy.

The water purveyor shall also cause discontinuance of water service if an air-gap separation system is compromised.

In lieu of discontinuance of service JEA may install, test, repair, or replace a backflow device at the customer's point of service and bill the customer for all costs associated with the install, test, repair, or replacement of a backflow device at the customer's premise.

B-6.02 Monetary Penalties and Imprisonment

Violations of provisions concerning cross-connections within the City Building Code may result in fines of up to \$100 or imprisonment of up to 60 days. Violations of JEA's Rules and Regulations pertinent to cross-connections may carry fines of not more than \$500 or not more than 90 days of imprisonment. Under both the Plumbing Code and JEA's Rules and Regulations, each day any violation shall continue shall constitute a separate offense.

Continued failure to respond to notices of violation may necessitate a site compliance inspection by JEA. JEA will assess a \$100 inspection fee on the customer of record.

B-7 Pertinent Sections of Local Codes

B-7.01 City Building Code - Chapter 341

(Construction Regulations and Building Codes)

Chapter 341 (Plumbing Code)

Section 1. Section 341.101, Ordinance Code is amended in part to read as follows:

Adoption of Florida Building Code 2001 as the Plumbing Code for the City of Jacksonville.

B-8 Backflow Prevention Devices (Illustrated)

B-8.01 Air-Gap Separation – AG

The term air-gap separation shall mean a physical separation between the free-flowing discharge end of a potable water supply pipeline and an open or non-pressure receiving vessel. An approved air-gap separation shall be a distance of at least two times the diameter of the supply pipe measured vertically above the top rim of the vessel, with a minimum distance of 1 inch.

Air gap.

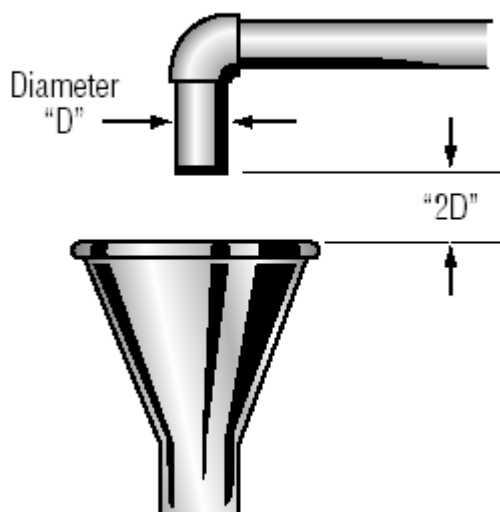

Air gap in a piping system.

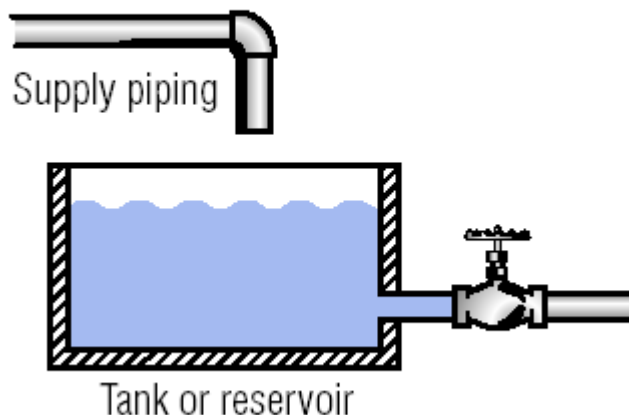

B-8.02 Double Check Valve Assembly – DCVA

An assembly composed of two single, independently acting, approved check valves, including tightly closing shut-off valves located at each end of the assembly and fitted with properly located test cocks.

A check valve that is drip-tight in the normal direction of flow when the inlet pressure is one psi and the outlet pressure is zero. The check valve shall permit no leakage in a direction reverse to the normal flow. The closure element (e.g., clapper) shall be internally weighted or otherwise internally loaded to promote rapid and positive closure and suitable connections for testing.

Double check valve.

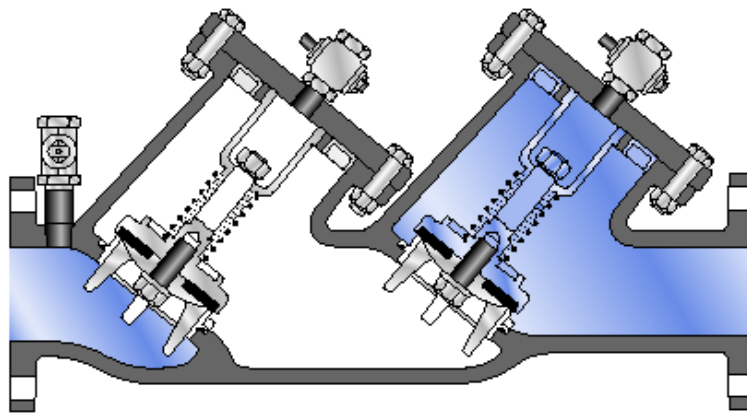

B-8.03 Double Check Detector Backflow Assembly – DCDA

A specially designed assembly composed of a line-sized approved double check valve assembly with a bypass containing a specific water meter and an approved double check valve assembly. Meter will register very low flows of water up to three gallons per minute and shall show a registration for all rates of flow. This assembly should only be used against a non-health hazard (i.e., pollutant).

Double check detector check.

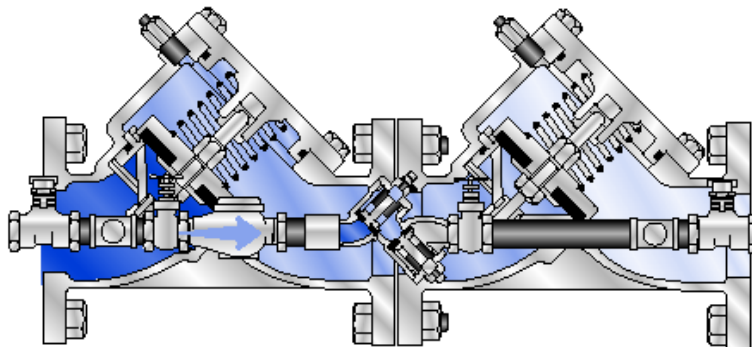

B – 8.04 Reduced Pressure Backflow Assembly – RP

A reduced-pressure principle backflow-prevention assembly (RP) is an assembly that shall contain two loaded, independently acting check valves with a hydraulically operating, mechanically independent pressure-differential relief valve located between the check valves. The RP is an assembly that can prevent backflow from backpressure and/or backsiphonage. An RP is designed for both high and low hazard applications.

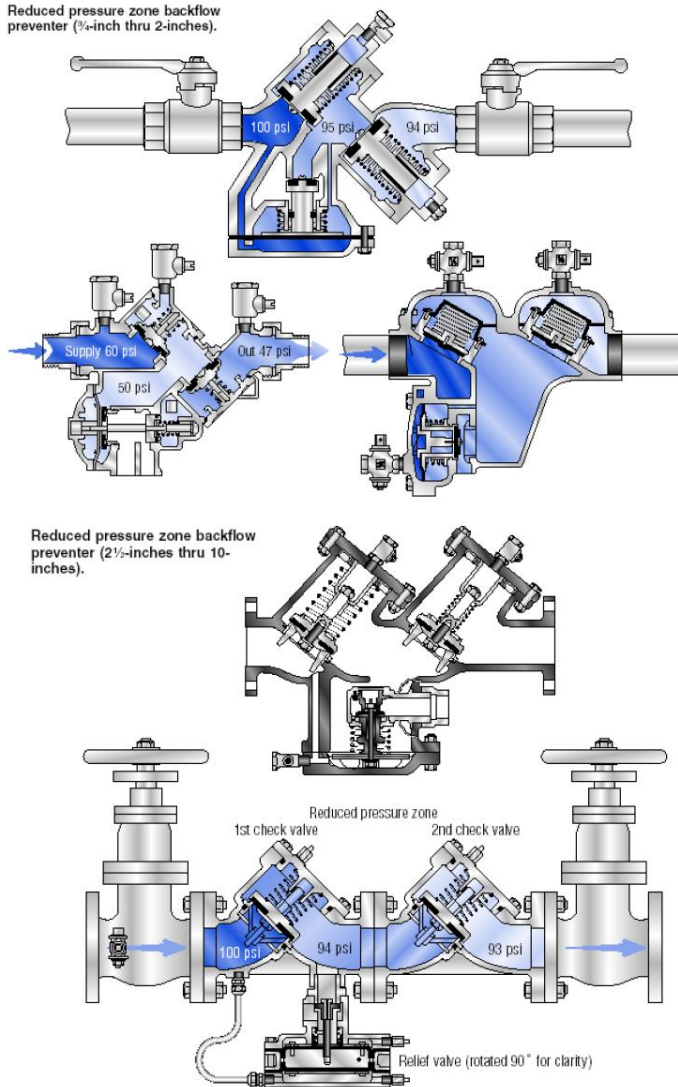

Reduced Pressure Detector Assembly – RPDA

A specially designed assembly composed of a line-sized approved reduced pressure principle backflow prevention assembly with a bypass containing a specific water meter and an approved reduced pressure principle backflow prevention assembly. The meter will show low flows of up to three gallons per minute. Assembly will protect against non-health hazard (i.e. pollutant) or a health hazard (i.e. contaminant).

B-8.05 Residential Dual-Check

An assembly composed of two single, independently acting, approved check valves, including tightly closing shut-off valves located at each end of the assembly.

The check valve shall permit no leakage in a direction reverse to the normal flow. The closure element (e.g., clapper) shall be internally weighted or otherwise internally loaded to promote rapid and positive closure. This assembly shall only be used at residential premises where reclaimed water is used for irrigation. Refer to section B-4.02 for requirements to utilize this device.

Residential dual check.

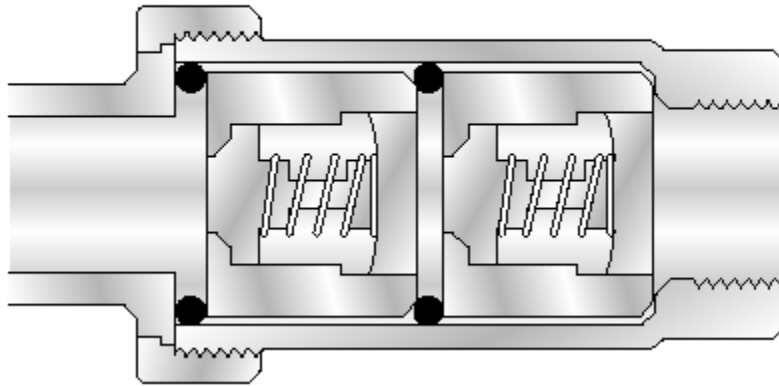

JEA RESIDENTIAL IRRIGATION CUSTOMER AFFIDAVIT FORM

1. THIS FORM TO BE COMPLETED BY PROPERTY OWNER OR RESIDENT RESPONSIBLE FOR JEA UTILITY ACCOUNT.
2. ONCE COMPLETED AND WITNESSED BY THE BACKFLOW INSTALLER THIS FORM SHALL BE SUBMITTED TO:
JEA CROSS CONNECTION CONTROL
21 W. CHURCH STREET T-8
JACKSONVILLE, FL 32202
EMAIL: backflow@jea.com

STATE OF FLORIDA

COUNTY OF _____

I _____ (PROPERTY OWNER OR RESPONSIBLE RESIDENT) ATTEST TO THE FOLLOWING:

- A. I AM AWARE THAT IT IS A VIOLATION OF JEA'S RULES & REGULATIONS FOR WATER, SEWER AND REUSE POLICY TO HAVE ADDITIONAL SERVICE CONNECTIONS BETWEEN THE IRRIGATION METER AND THE BACKFLOW PREVENTER, AND
- B. TO THE BEST OF MY KNOWLEDGE, THERE ARE NO ADDITIONAL SERVICE CONNECTIONS BETWEEN THE IRRIGATION METER AND THE BACKFLOW PREVENTER.
- C. BACKFLOW PREVENTER LOCATION IS IN A LOCATION THAT IS EASILY ACCESSIBLE FOR JEA AND THIRD PARTY ACCESS FOR INSPECTION.

(PRINT NAME)

OWNER
 RESPONSIBLE RESIDENT

(SIGNATURE)

(DATE)

RESIDENCE REQUESTING ALTERNATE LOCATION OF BACKFLOW ASSEMBLY INSTALLATION:

ADDRESS: _____
(STREET) (CITY) (STATE)

WITNESS NAME: _____ WITNESS: _____

WITNESS ADDRESS: STREET: _____ COUNTY: _____

WITNESS DATE: _____

REFERENCES

- “Accepted Procedure and Practice in Cross-Connection Control,” Pacific Northwest Section, AWWA, 1973, 1985, 1990,
- Cincinnati Water Works - Division L-“Cross-Connection Control and Water Quality Protection,” Cincinnati, Ohio November 18, 1974.
- “Cross-Connections and Backflow Prevention,” AWWA, 1974.
- “Cross-Connection Control Manual,” Division of Sanitary Engineering, Tennessee Department of Public Health' 1975.
- “Cross-Connection Control Manual”, U.S. Environmental Protection Agency, Washington, D. C., 1973, 1989, 2003. “Cross-Connection Control Manual,”
- “Manual of Cross-Connection Control Policies,” Tampa Water Department, Tampa, Florida, June 1981.
- Public Law 93 -523, “Safe Drinking Water Act,” - 16, 1974 and amendments 1996.
- “Recommended Practice for Backflow Prevention and Cross-Connection Control,” AWWA Manual MI 4, 1960, 1990, 2004.
- “Rules of the Department of Environmental Protection, chapter 62-550 and 62-555, State of Florida- Department of Environmental Protection,” Water Supplies
- Standard Building Code 2001, Revision

Appendix C.
Commercial/Industrial Questionnaire

(This page left blank.)



Industrial Pretreatment

COMMERCIAL/INDUSTRIAL QUESTIONNAIRE

IMPORTANT: If your company has multiple locations, please copy this form and submit a separate questionnaire for each location within the JEA service area.

1.1 Facility Name: _____ Date: _____

1.2 Facility Address: _____

1.3 Name and title of person completing questionnaire: _____

1.4 Phone #: _____ Fax # (optional): _____

2.1 Type of Business: Industrial Commercial Manufacturing Other

(a) Total number of employees: 0-5 6-15 16-50 51-100 101-300 300 +

(b) Please check one of the following:

- New Business
- Existing Business
- Facility not yet constructed

2.2 (a) Are any wastes hauled off site: Yes No

(b) If yes, please indicate the type of waste:

- Acid/Alkalies Solvents Heavy Metal
- Oil & Grease Paint Other _____
- Radioactive Pesticides

2.3 What type of operating permits does your facility currently have:

- State/Federal Hazardous waste State/Federal Air Quality
- NPDES/ Stormwater JEA Industrial User Discharge
- Other _____ None

2.4 Estimate the volume of water used at your facility: _____ gallons per day

2.5 Where is water used in the facility:

- Process Boiler feed water Non-contact cooling
- Sanitary Irrigation Other: _____
- Product None



Industrial Pretreatment

COMMERCIAL/INDUSTRIAL QUESTIONNAIRE

IMPORTANT: If your company has multiple locations, please copy this form and submit a separate questionnaire for each location within the JEA service area.

2.6 Please describe your business (Attach a separate sheet if necessary): _____

2.7 Estimated volume of wastewater discharged to the sanitary sewer: _____ gallons per day

2.8 Anticipated start date of first discharge? _____

2.9 (a) Does the facility treat wastewater prior to discharge? __ Yes __ No
(b) If yes, please describe: _____

Submit the completed questionnaire to the following address:

JEA
Industrial Pretreatment
21 W. Church St., T-8
Jacksonville, FL 32202-3139

Appendix D.
Reclaimed Water System Service Area

(This page left blank.)

JEA Rules and Regulations for Water, Sewer, & Reclaimed Services
Appendix D. Reclaimed Water System Service Area

Please contact W/WW Systems Planning for an updated copy of the Reclaimed Water Services Territory.