

SANITARY SEWER MANHOLE FRAME AND COVER

PLATE S-1

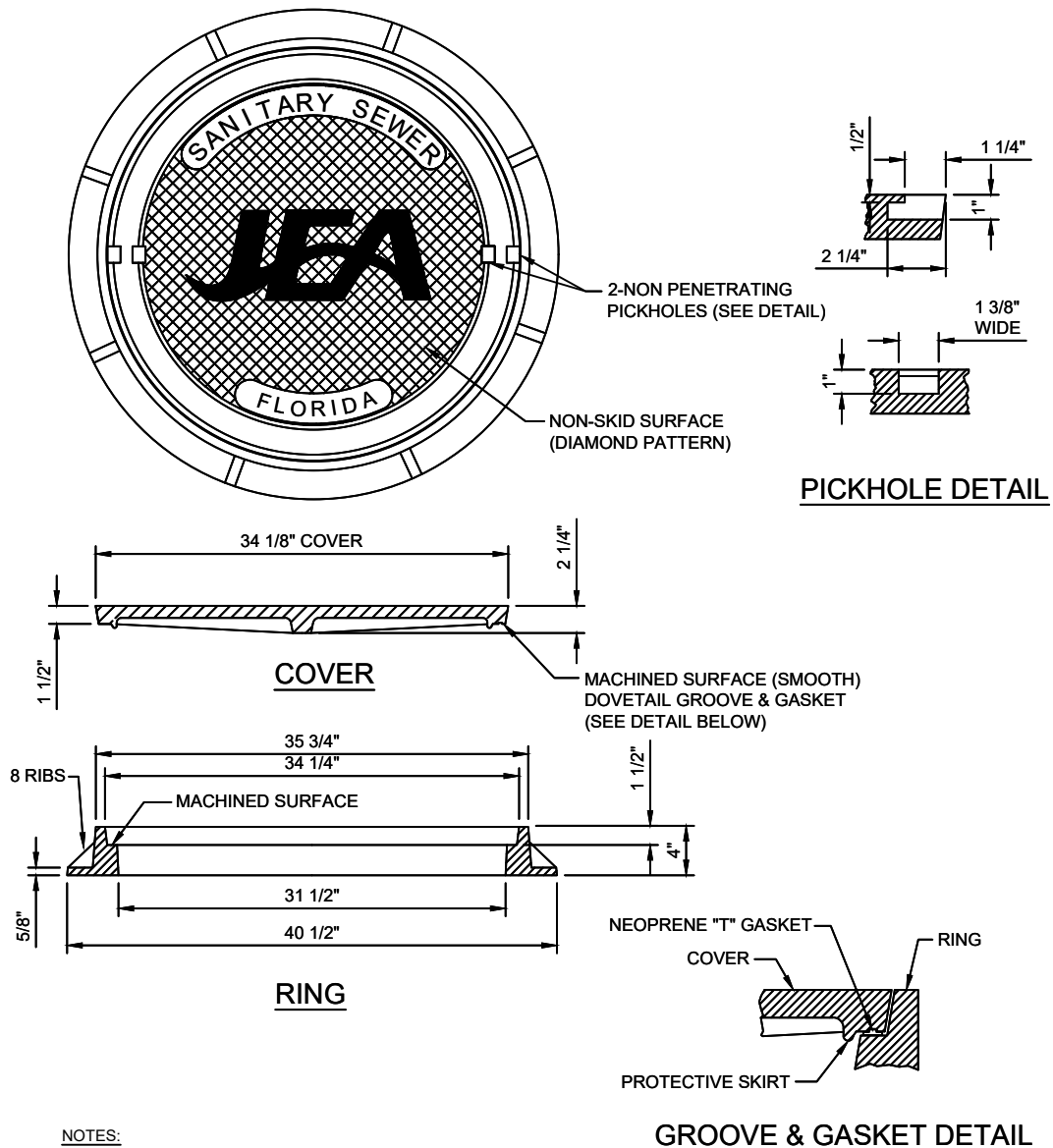

NOTES:

1. MATERIAL: ASTM A-48 CLASS 35B GRAY IRON.
2. RING WEIGHT 230 LBS APPROX.
3. COVER WEIGHT 230 LBS. APPROX.
4. ALL DIMENSIONS ARE SHOWN IN INCHES.
5. FOR MANHOLES WHICH WILL BE MAINTAINED BY JEA (INCLUDING UTILITY DEDICATION PROJECTS), THE COVER SHALL INCLUDE THE "JEA" LOGO AND A NEOPRENE GASKET.
6. FOR MANHOLES WHICH WILL BE MAINTAINED BY PARTIES OTHER THAN JEA (SUCH AS PRIVATE SEWER COLLECTION SYSTEMS, PRIVATE (FORCE MAIN) PUMP OUT BOX AND SYSTEMS NOT MAINTAINED BY JEA), THE COVER SHALL INCLUDE "SANITARY SEWER" GENERIC LETTERING (NO "JEA" LOGO OR NEOPRENE GASKET).

SANITARY SEWER CONCRETE TYPE "A" MANHOLE 8"-21" SEWERS

PLATE S-2, S-3

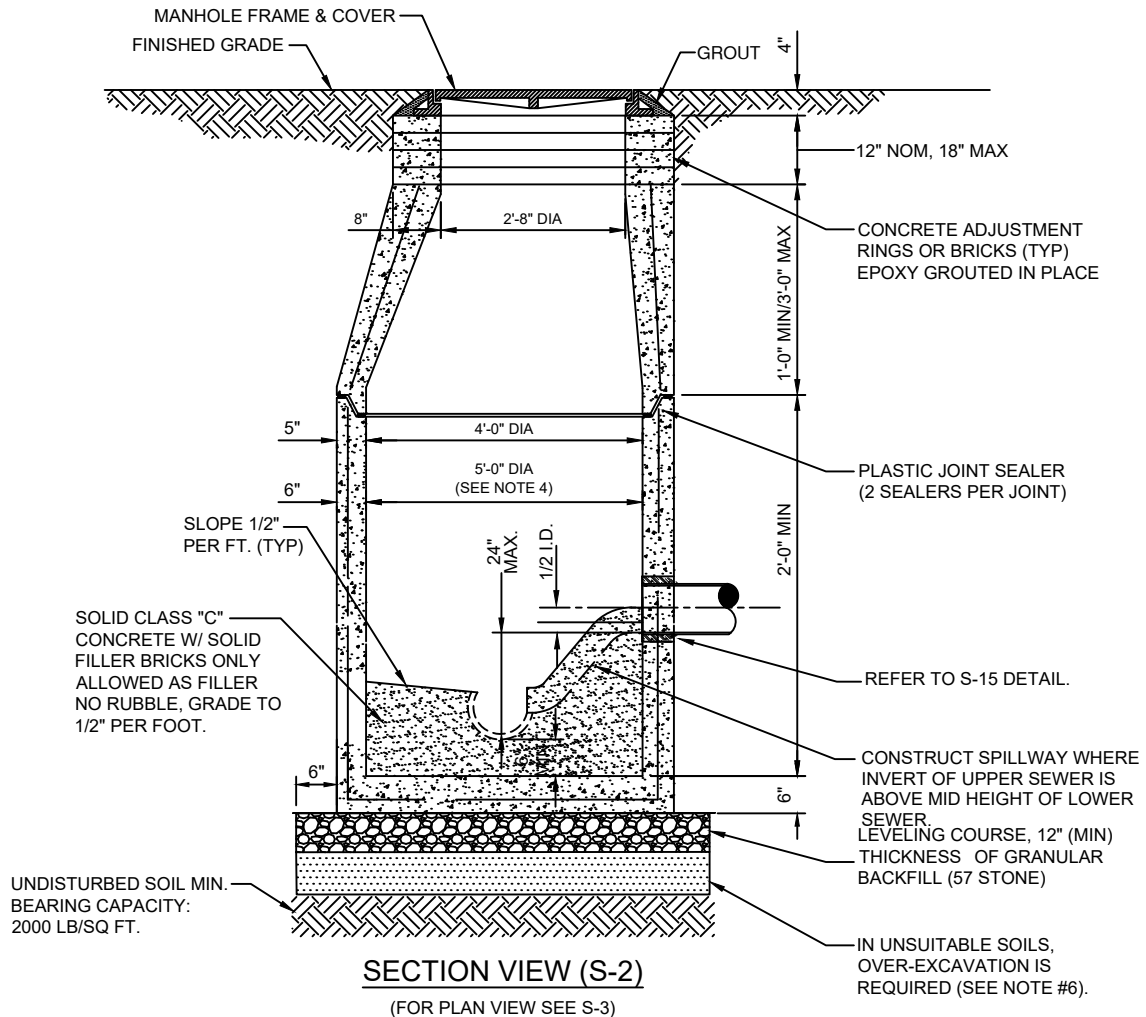

NOTES:

1. PRECAST MANHOLE SECTIONS TO BE MANUFACTURED IN ACCORDANCE WITH THE LATEST EDITIONS OF A.S.T.M. C-478 WITH 4000 LB. CONC., TYPE II CEMENT. ALL LIFTING HOLES AND OUTSIDE INSERTS SHALL BE FILLED WITH NON-SHRINK GROUT AND COATED WITH BITUMINOUS WATERPROOFING MATERIAL.
2. THE INTERIOR AND EXTERIOR OF MANHOLE AND ADJUSTING RINGS SHALL BE GIVEN TWO COATS OF BITUMINOUS WATERPROOFING MATERIAL.
3. IF SPECIALTY LINER IS TO BE INSTALLED ON INSIDE SURFACE OF MANHOLE, THE BITUMINOUS WATERPROOFING MATERIAL SHALL BE OMITTED ON THE INSIDE.
4. JUNCTION MANHOLE (CLOSEST TO WETWELL) SHALL BE 5' DIA WITH SPECIALTY LINER.
5. SEAL ALL EXTERIOR JOINTS PER PLATE S-17.
6. IN SILTS, CLAY OR HIGHLY ORGANIC SOILS (FINE-GRAINED SOILS INCLUDING SOIL GROUPS ML, CL, OL, MH, CH, OH AND PT) THE SOILS SHALL BE OVER-EXCAVATED AN ADDITIONAL 24" (AT A MIN.) AND BACKFILLED WITH AASHTO CLASS A-3 SOIL (COMPACTED TO 98%, ASTM D1557) OR OVER-EXCAVATE AN ADDITIONAL 12" (AT A MIN.) AND BACKFILL WITH GRANULAR BACKFILL (57 STONE).

MICRO-TUNNELING WORK SHAFT

PLATE S-2B

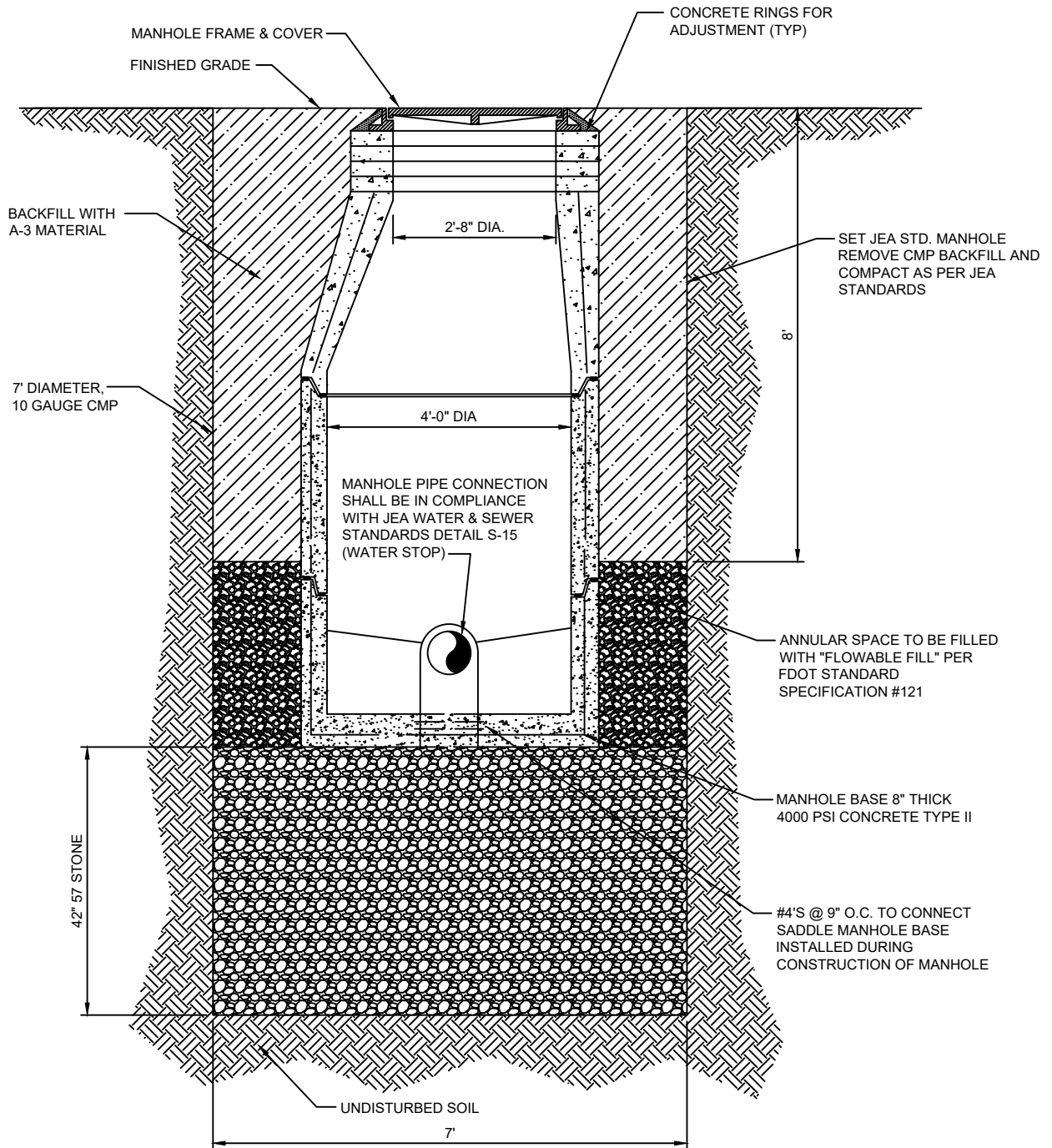

SECTION VIEW

TYPE 'A' MANHOLE PLAN VIEW

PLATE S-3

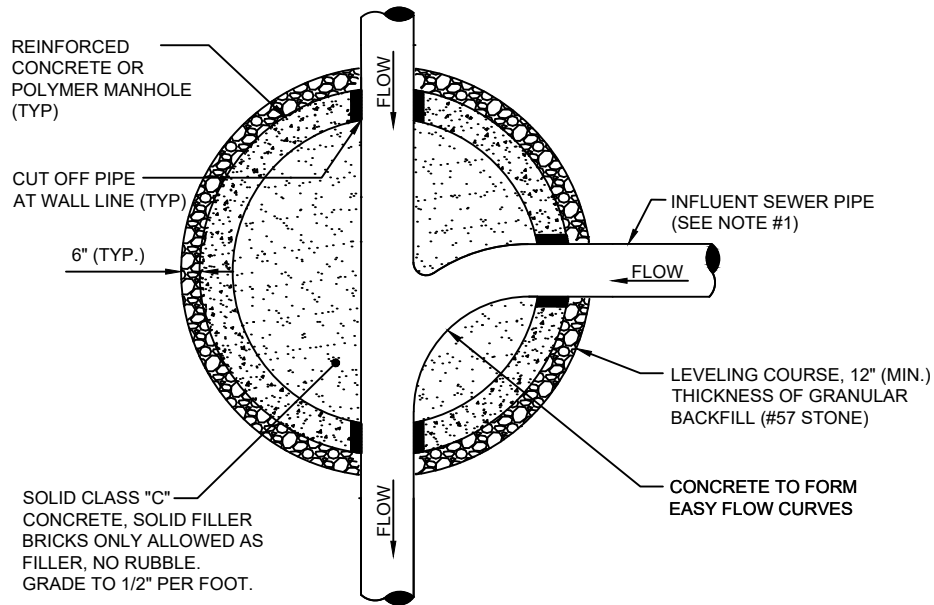

PLAN VIEW (S-3)

(FOR SECTION VIEW SEE S-2, S-2A)

NOTES:

1. THE ANGLE BETWEEN ALL INFLUENT FLOW CHANNELS AND EFFLUENT PIPE SHALL BE BETWEEN 90° - 180° UNLESS OTHERWISE APPROVED BY JEA.

SANITARY SEWER CONCRETE TYPE "B" MANHOLE 8"-10" SEWERS

PLATE S-4, S-5

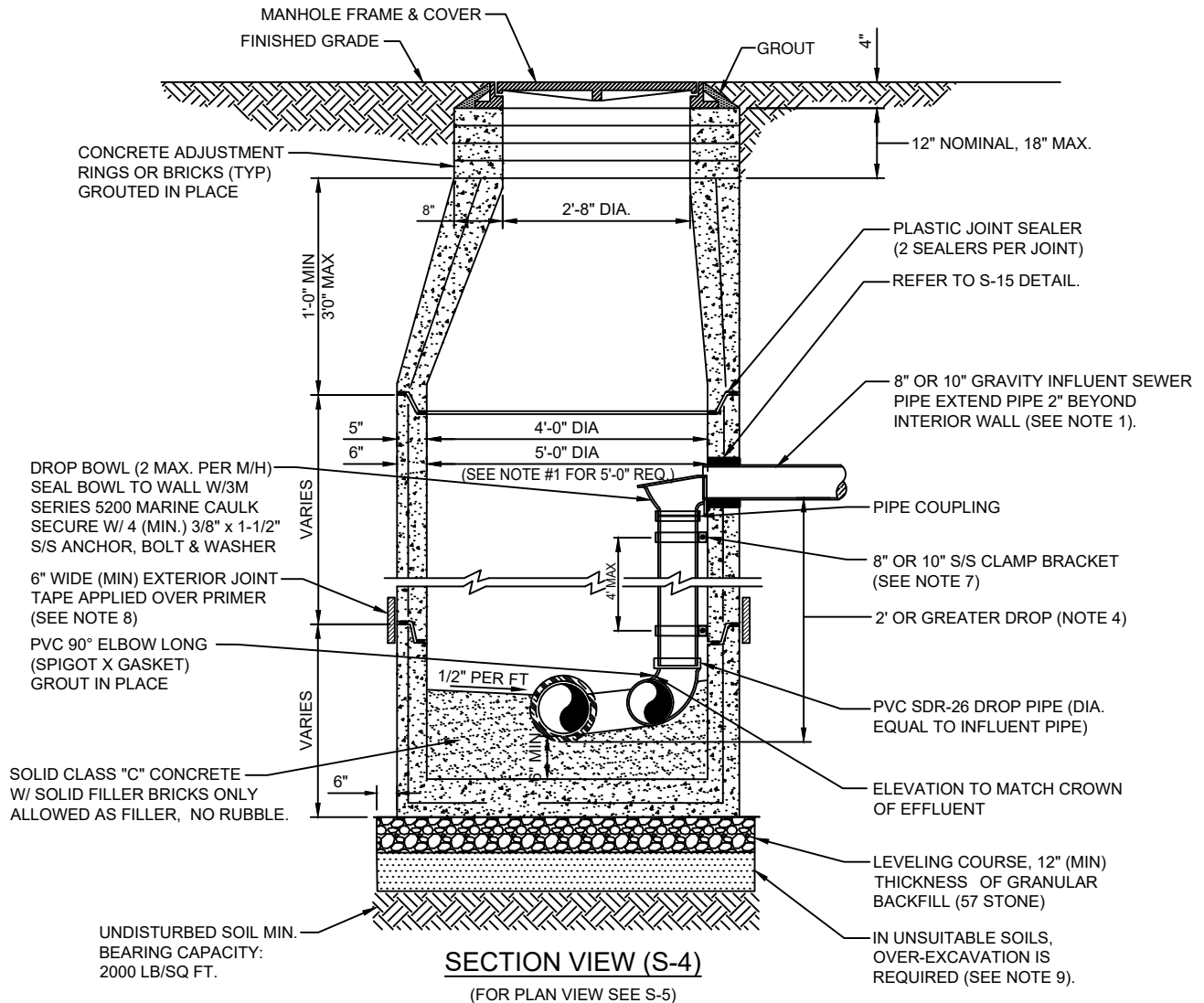

NOTES:

1. THIS ASSEMBLY IS FOR 8" OR 10" GRAVITY INFLUENT LINES ONLY. NEW CONSTRUCTION ONLY NO FORCE MAINS LARGER THAN 6". MAXIMUM OF 2 INSIDE DROP BOWLS PER MANHOLE. A 5'-0" DIA. MANHOLE (6" THICK WALLS) IS REQUIRED IF TWO INSIDE DROPS ARE CONSTRUCTED WITH ONE OR BOTH BEING 10" SIZE. DROP BOWL BY RELINER OR APPROVED EQUAL REQUIRED. THE INSIDE DROP FOR AN 8" HIGH-LINE SHALL BE CONSTRUCTED SIMILAR TO ABOVE (SEE PLATE S-5).
2. PRECAST MANHOLE SECTIONS TO BE MANUFACTURED IN ACCORDANCE WITH THE LATEST EDITIONS OF A.S.T.M. C-478 WITH 4000 LB. CONC., TYPE II CEMENT. ALL LIFTING HOLES AND OUTSIDE INSERTS SHALL BE FILLED WITH NON-SHRINK GROUT AND COATED WITH BITUMINOUS WATERPROOFING MATERIAL.
3. THE INTERIOR AND EXTERIOR OF MANHOLE AND THE INTERIOR OF ADJUSTMENT RINGS SHALL BE GIVEN TWO COATS OF BITUMINOUS WATERPROOFING MATERIAL.
4. TYPE "B" MANHOLE MUST BE USED FOR 2' OR GREATER INFLUENT PIPE DROPS.
5. IN THE EVENT A SPECIALTY LINING IS REQUIRED, THE DROP BOWL ASSEMBLY SHALL BE INSTALLED PRIOR TO LINER APPLICATION.
6. A TYPE "D" MANHOLE SHALL BE UTILIZED WHEN THREE OR MORE (2' OR GREATER) DROPS ARE INVOLVED OR WHEN INFLUENT PIPES AREA LARGER THAN 10" IN SIZE.
7. ADJUSTABLE CLAMPING BRACKET (MIN. 2 PER DROP BOWL ASSY), 1-1/2" WIDE, 11 GA. W/ 3/8" DIA. 18-8 PINCH BOLTS AND NUTS. SECURE TO M/H WALL WITH (2) 3/8" X 1" BOLT, ANCHOR & WASHER PER BRACKET ASSY. ALL 304 OR 316 STAINLESS STEEL MATERIALS.
8. SEAL ALL EXTERIOR JOINTS PER S-17
9. IN SILTS, CLAY OR HIGHLY ORGANIC SOILS (FINE-GRAINED SOILS INCLUDING SOIL GROUPS ML, CL, OL, MH, CH, OH AND PT) THE SOILS SHALL BE OVER-EXCAVATED AN ADDITIONAL 24" (AT A MIN.) AND BACKFILLED WITH AASHTO CLASS A-3 SOIL (COMPACTED TO 98%, ASTM D1557) OR OVER-EXCAVATE AN ADDITIONAL 12" (AT A MIN.) AND BACKFILL WITH GRANULAR BACKFILL (57 STONE).

SANITARY SEWER POLYMER TYPE "B" MANHOLE 8"-10" SEWERS

PLATE S-4A, S-5

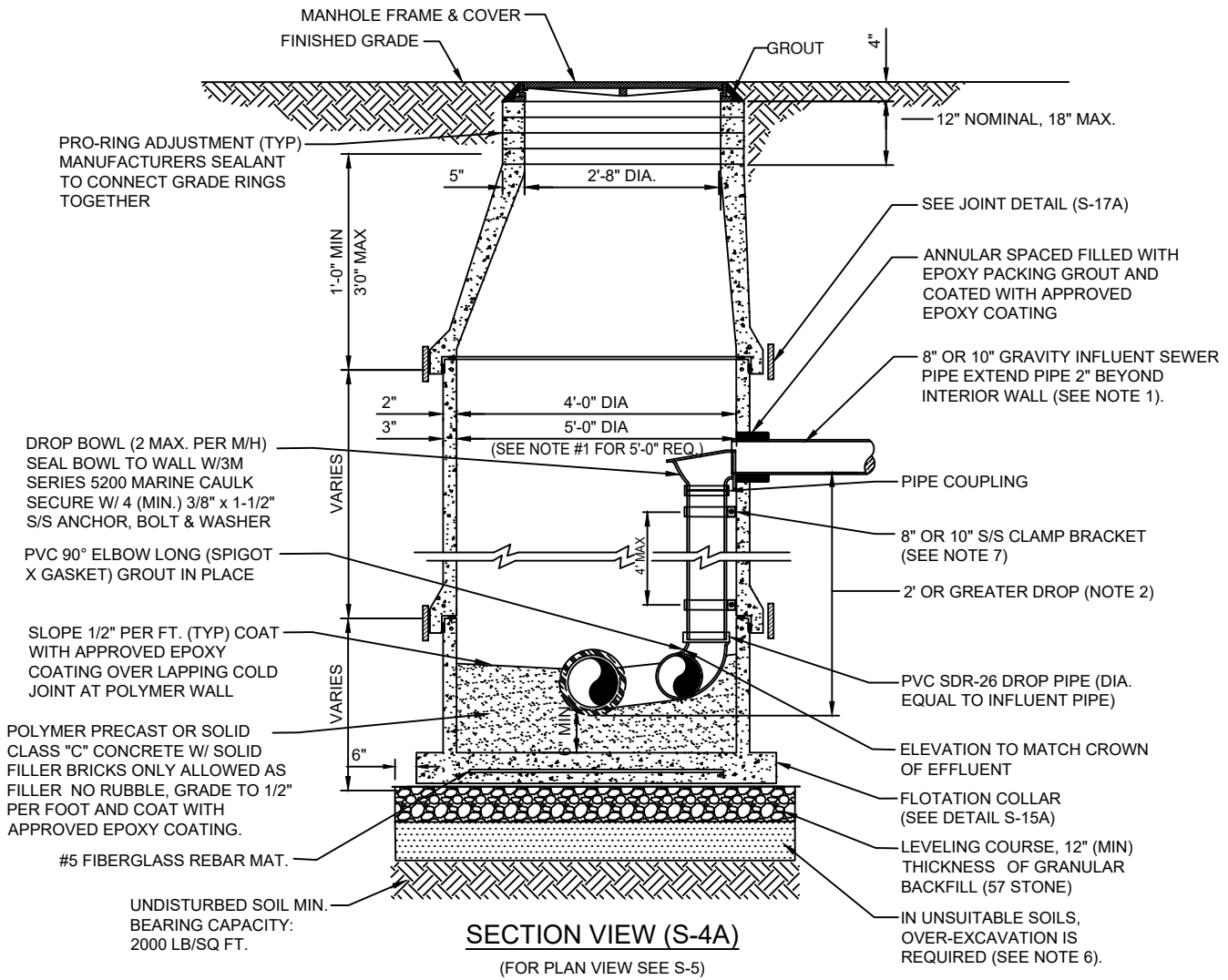

NOTES:

1. THIS ASSEMBLY IS FOR 8" OR 10" GRAVITY INFLUENT LINES ONLY. NEW CONSTRUCTION ONLY NO FORCE MAINS LARGER THAN 6". MAXIMUM OF 2 INSIDE DROP BOWLS PER MANHOLE. A 5'-0" DIA. MANHOLE (6" THICK WALLS) IS REQUIRED IF TWO INSIDE DROPS ARE CONSTRUCTED WITH ONE OR BOTH BEING 10" SIZE. DROP BOWL BY RELINER OR APPROVED EQUAL REQUIRED. THE INSIDE DROP FOR AN 8" HIGH-LINE SHALL BE CONSTRUCTED SIMILAR TO ABOVE (SEE PLATE S-5).
2. TYPE "B" MANHOLE MUST BE USED FOR 2' OR GREATER INFLUENT PIPE DROPS.
3. A TYPE "D" MANHOLE SHALL BE UTILIZED WHEN THREE OR MORE (2' OR GREATER) DROPS ARE INVOLVED OR WHEN INFLUENT PIPES AREA LARGER THAN 10" IN SIZE.
4. ADJUSTABLE CLAMPING BRACKET (MIN. 2 PER DROP BOWL ASSY). 1-1/2" WIDE, 11 GA. W/ 3/8" DIA. 18-8 PINCH BOLTS AND NUTS. SECURE TO M/H WALL WITH (2) 3/8" X 1" BOLT, ANCHOR & WASHER PER BRACKET ASSY. ALL 304 OR 316 STAINLESS STEEL MATERIALS.
5. SEAL ALL EXTERIOR JOINTS PER PLATE S-17A
6. IN SILTS, CLAY OR HIGHLY ORGANIC SOILS (FINE-GRAINED SOILS INCLUDING SOIL GROUPS ML, CL, OL, MH, CH, OH AND PT) THE SOILS SHALL BE OVER-EXCAVATED AN ADDITIONAL 24" (AT A MIN.) AND BACKFILLED WITH AASHTO CLASS A-3 SOIL (COMPACTED TO 98%, ASTM D1557) OR OVER-EXCAVATE AN ADDITIONAL 12" (AT A MIN.) AND BACKFILL WITH GRANULAR BACKFILL (57 STONE).

TYPE 'B' MANHOLE PLAN VIEW

PLATE S-5

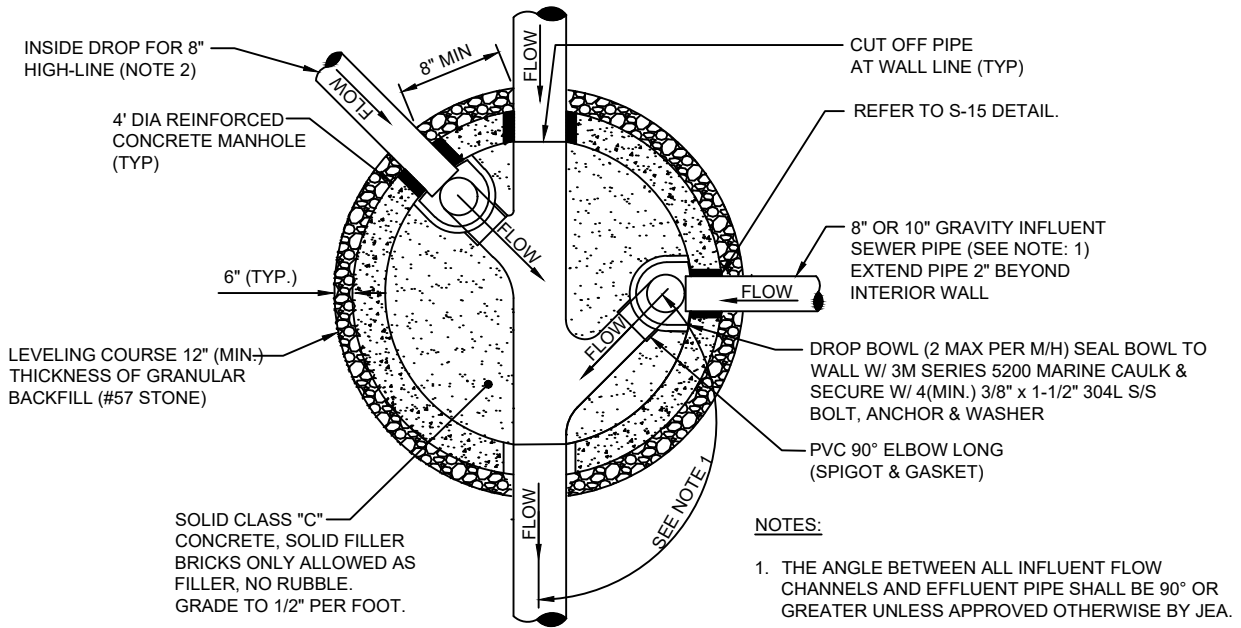

NOTES:

1. THE ANGLE BETWEEN ALL INFLUENT FLOW CHANNELS AND EFFLUENT PIPE SHALL BE 90° OR GREATER UNLESS APPROVED OTHERWISE BY JEA.
2. THE 8" HIGH-LINE, WHERE UTILIZED, SHALL ENTER THE MANHOLE OFF-CENTER AS SHOWN ABOVE.

PLAN VIEW (S-5)

(FOR SECTION VIEW SEE S-4)

SANITARY SEWER CONCRETE TYPE "C" MANHOLE 8"-21" SEWERS

PLATE S-6

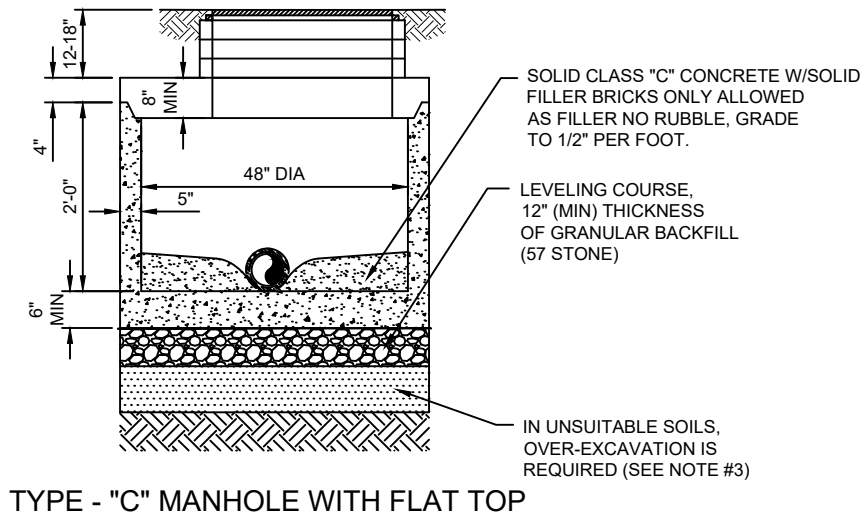
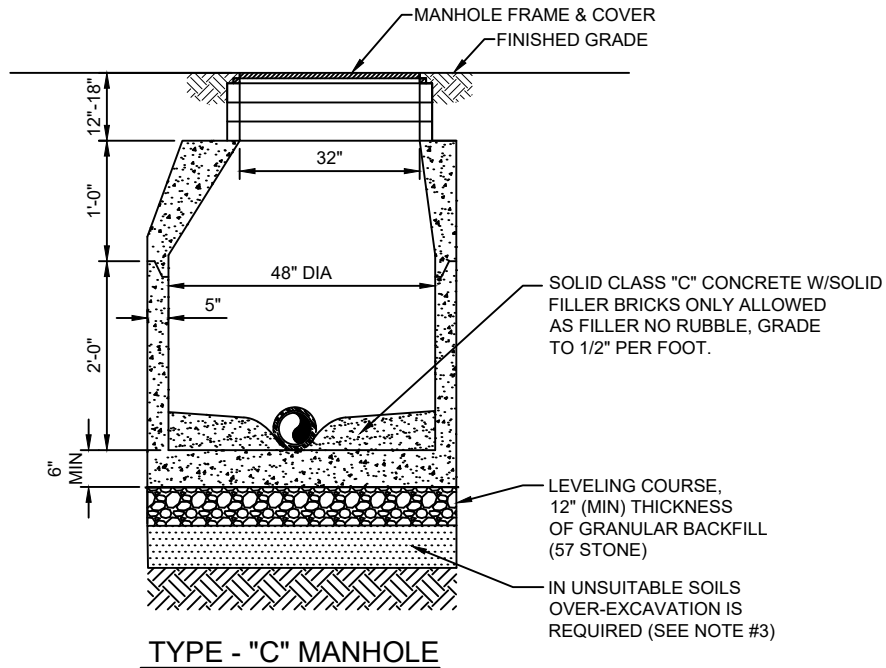

SECTION VIEWS

NOTES:

1. PRECAST MANHOLE SECTIONS TO BE MANUFACTURED IN ACCORDANCE WITH THE LATEST EDITIONS OF A.S.T.M. C-478 WITH 4000 LB. CONC., TYPE II CEMENT. ALL LIFTING HOLES AND OUTSIDE INSERTS SHALL BE FILLED WITH NON-SHRINK GROUT AND COATED WITH BITUMINOUS WATERPROOFING MATERIAL.
2. THE INTERIOR AND EXTERIOR OF MANHOLE AND INTERIOR OF ADJUSTMENT RINGS SHALL BE GIVEN TWO COATS OF BITUMINOUS WATERPROOFING MATERIAL.
3. IN SILTS, CLAY OR HIGHLY ORGANIC SOILS (FINE-GRAINED SOILS INCLUDING SOIL GROUPS ML, CL, OL, MH, CH, OH AND PT) THE SOILS SHALL BE OVER-EXCAVATED AN ADDITIONAL 24" (AT A MIN.) AND BACKFILLED WITH AASHTO CLASS A-3 SOIL (COMPACTED TO 98%, ASTM D1557) OR OVER-EXCAVATE AN ADDITIONAL 12" (AT A MIN.) AND BACKFILL WITH GRANULAR BACKFILL (57 STONE).
4. SEAL ALL EXTERIOR JOINTS PER PLATE S-17

SANITARY SEWER POLYMER TYPE "C" MANHOLE 8"-21" SEWERS

PLATE S-6A

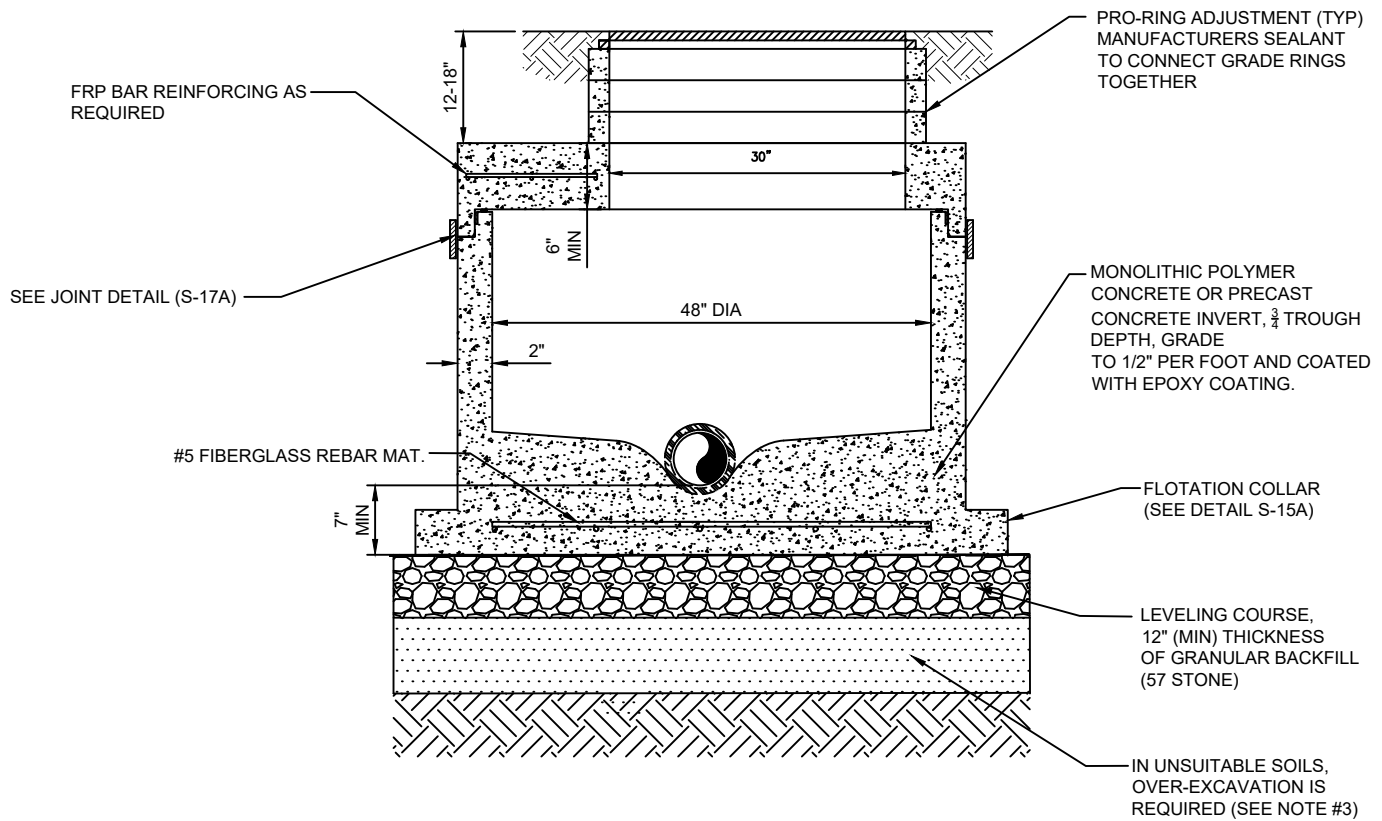

TYPE - "C" MANHOLE WITH FLAT TOP

SECTION VIEWS

NOTES:

1. IN SILTS, CLAY OR HIGHLY ORGANIC SOILS (FINE-GRAINED SOILS INCLUDING SOIL GROUPS ML, CL, OL, MH, CH, OH AND PT) THE SOILS SHALL BE OVER-EXCAVATED AN ADDITIONAL 24" (AT A MIN.) AND BACKFILLED WITH AASHTO CLASS A-3 SOIL (COMPACTED TO 98%, ASTM D1557) OR OVER-EXCAVATE AN ADDITIONAL 12" (AT A MIN.) AND BACKFILL WITH GRANULAR BACKFILL (57 STONE).
2. SEAL ALL EXTERIOR JOINTS PER PLATE S-17A

SANITARY SEWER CONCRETE TYPE "D" MANHOLE 12"-21" SEWERS

PLATE S-7, S-8

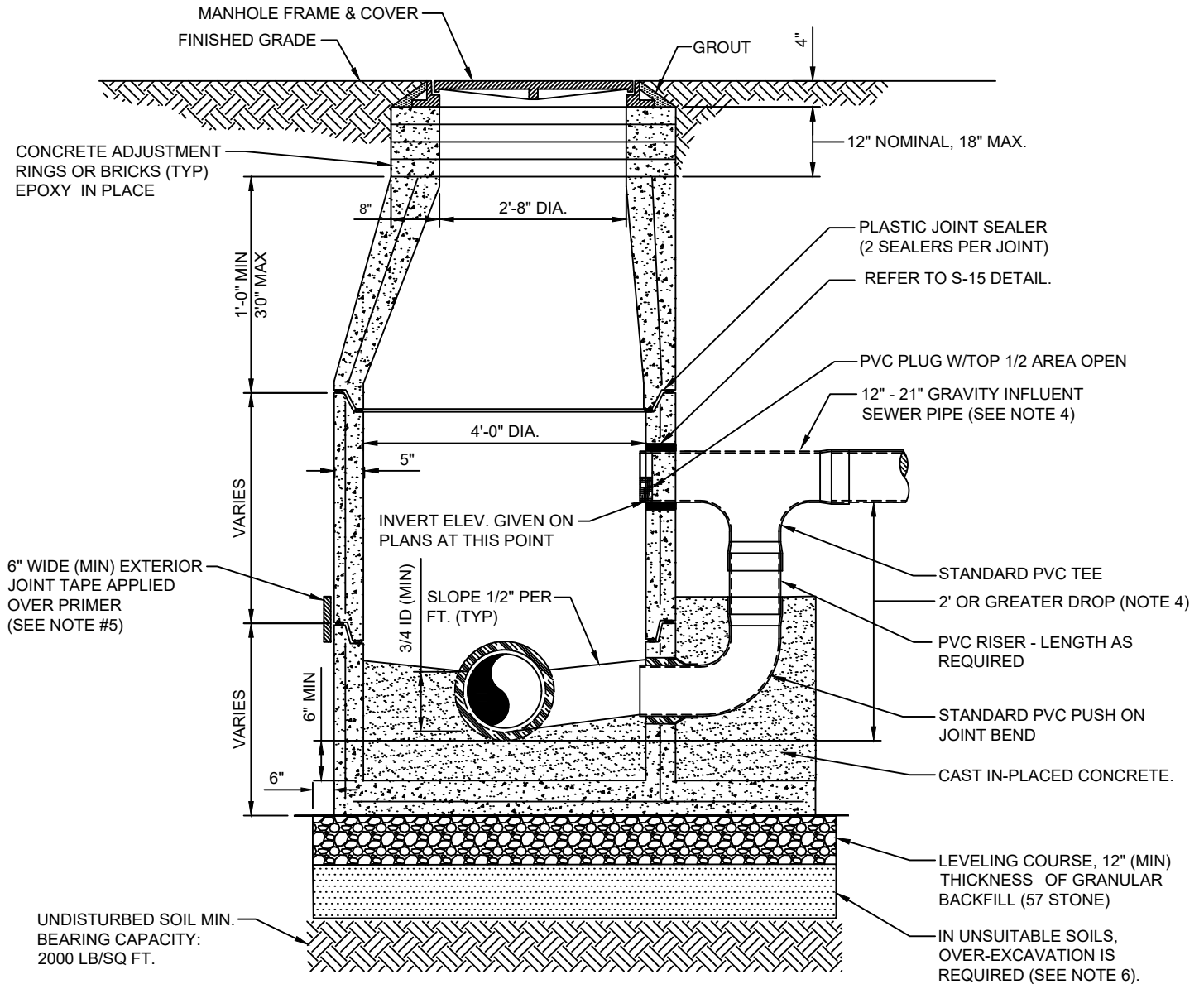

SECTION VIEW (S-7)

(FOR PLAN VIEW SEE S-8)

NOTES:

1. PRECAST MANHOLE SECTIONS TO BE MANUFACTURED IN ACCORDANCE WITH THE LATEST EDITIONS OF A.S.T.M. C-478 WITH 4000 LB. CONC., TYPE II CEMENT. ALL LIFTING HOLES AND OUTSIDE INSERTS SHALL BE FILLED WITH NON-SHRINK GROUT AND COATED WITH BITUMINOUS WATERPROOFING MATERIAL.
2. THE INTERIOR AND EXTERIOR OF MANHOLE AND THE INTERIOR OF THE ADJUSTMENT RINGS SHALL BE GIVEN TWO COATS OF BITUMINOUS WATERPROOFING MATERIAL.
3. IF SPECIALTY LINER IS TO BE INSTALLED ON INSIDE SURFACE OF MANHOLE, THE BITUMINOUS WATERPROOFING SHALL BE, OMITTED ON INSIDE.
4. TYPE "D" MANHOLE SHALL BE USED FOR 12" OR LARGER INFLUENT PIPES W/ 2' OR GREATER INFLUENT DROP.
5. ALL M/H JOINTS BELOW THE TOP CONE SECTION SHALL INCLUDE A 6" WIDE (MIN) EXTERIOR JOINT TAPE (W/PRIMER). TAPE ON THE CONE SECTION IS OPTIONAL.
6. IN SILTS, CLAY OR HIGHLY ORGANIC SOILS (FINE-GRAINED SOILS INCLUDING SOIL GROUPS ML, CL, OL, MH, CH, OH AND PT) THE SOILS SHALL BE OVER-EXCAVATED AN ADDITIONAL 24" (AT A MIN.) AND BACKFILLED WITH AASHTO CLASS A-3 SOIL (COMPACTED TO 98%, ASTM D1557) OR OVER-EXCAVATE AN ADDITIONAL 12" (AT A MIN.) AND BACKFILL WITH GRANULAR BACKFILL (57 STONE).
7. SEAL ALL EXTERIOR JOINTS PER PLATE S-17

SANITARY SEWER POLYMER TYPE "D" MANHOLE 12"-21" SEWERS

PLATE S-7A, S-8

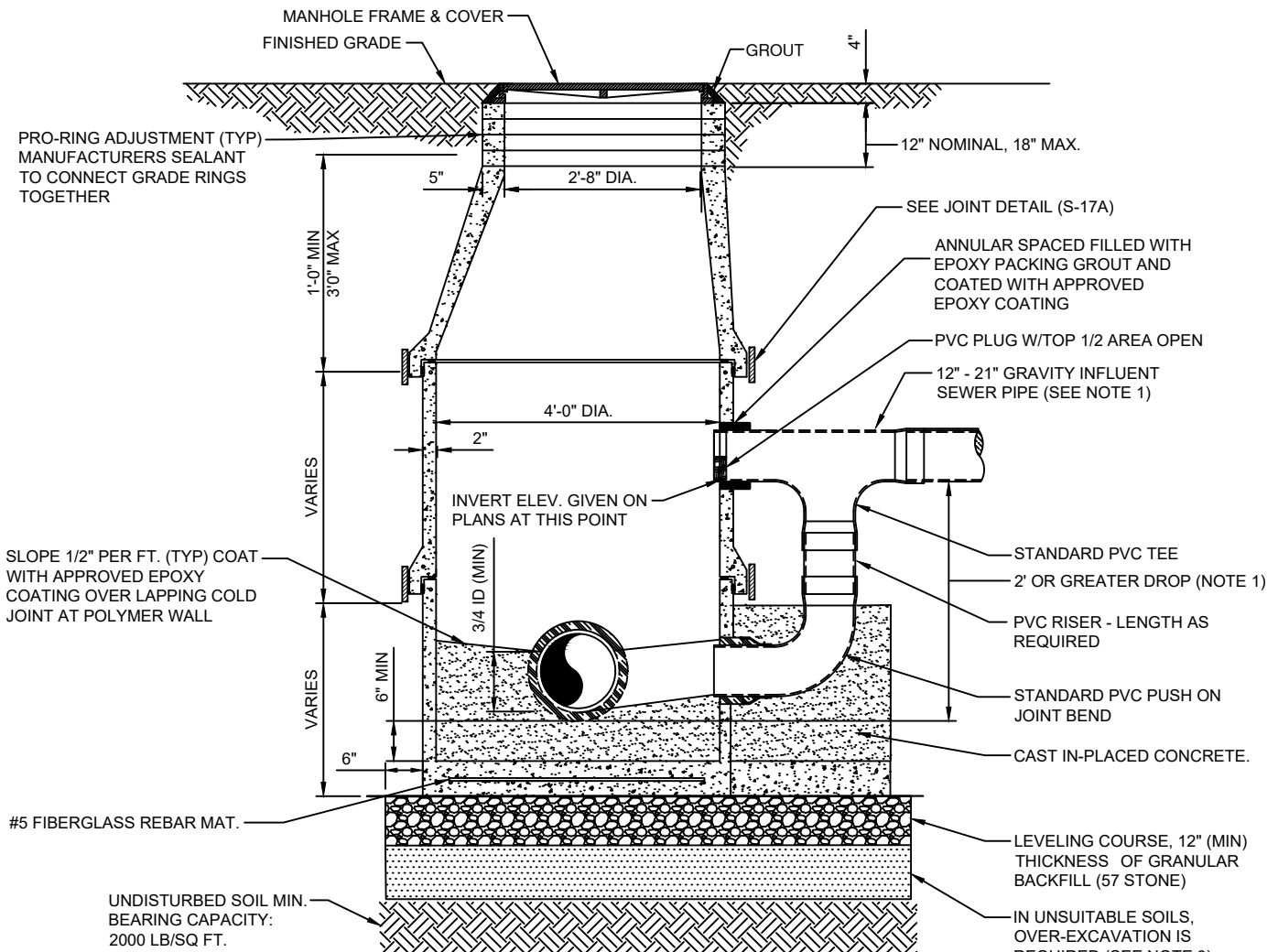

SECTION VIEW (S-7A)
(FOR PLAN VIEW SEE S-8)

NOTES:

1. TYPE "D" MANHOLE SHALL BE USED FOR 10" OR LARGER INFLUENT PIPES W/ 2' OR GREATER INFLUENT DROP.
2. SEAL ALL EXTERIOR JOINTS PER PLATE S-17A
3. IN SILTS, CLAY OR HIGHLY ORGANIC SOILS (FINE-GRAINED SOILS INCLUDING SOIL GROUPS ML, CL, OL, MH, CH, OH AND PT) THE SOILS SHALL BE OVER-EXCAVATED AN ADDITIONAL 24" (AT A MIN.) AND BACKFILLED WITH AASHTO CLASS A-3 SOIL (COMPACTED TO 98%, ASTM D1557) OR OVER-EXCAVATE AN ADDITIONAL 12" (AT A MIN.) AND BACKFILL WITH GRANULAR BACKFILL (57 STONE).

TYPE 'D' MANHOLE PLAN VIEW

PLATE S-8

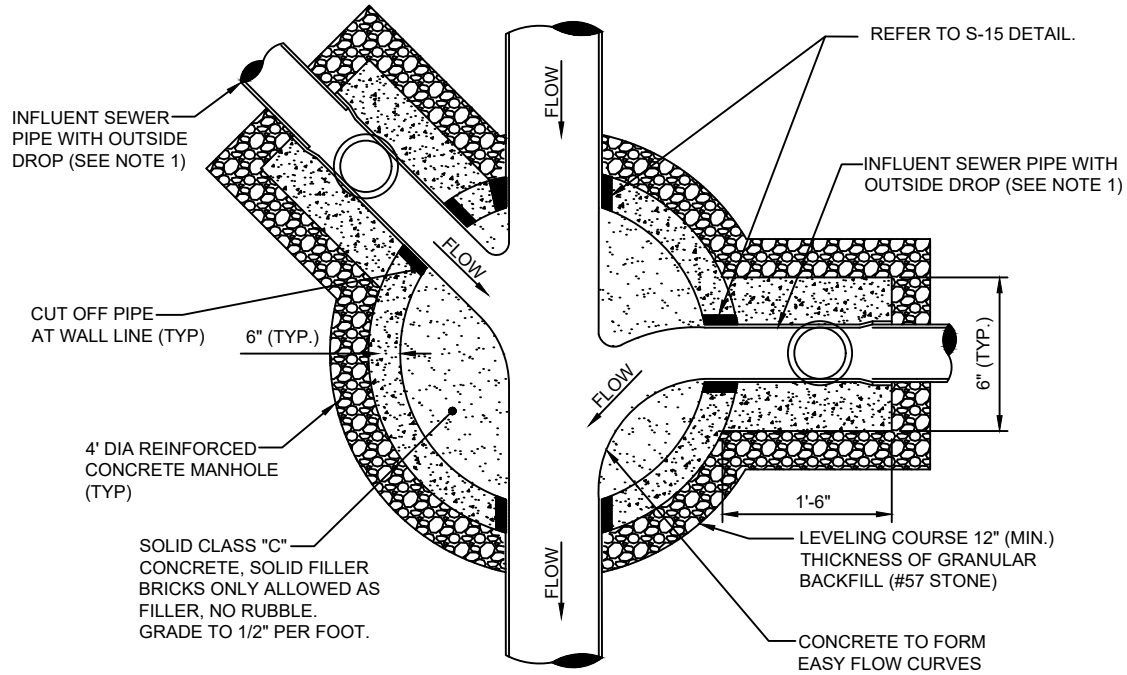

PLAN VIEW (S-8)

(FOR SECTION VIEW SEE S-7)

NOTES:

1. THE ANGLE BETWEEN ALL INFLUENT FLOW CHANNELS AND EFFLUENT PIPE SHALL BE 90° OR GREATER UNLESS APPROVED OTHERWISE BY JEA.
2. THE INTERIOR AND EXTERIOR OF THE MANHOLE AND THE INTERIOR OF THE ADJUSTMENT RINGS SHALL BE GIVEN 2 COATS OF BITUMINOUS WATERPROOFING MATERIAL.
3. IF SPECIALITY LINER IS TO BE INSTALLED ON INSIDE OF MANHOLE, THE BITUMINOUS WATERPROOFING MATERIAL SHALL BE OMITTED ON THE INSIDE.
4. TYPE "D" MANHOLES SHALL BE USED FOR 12" OR LARGER INFLUENT PIPES W/ 2' OR GREATER INFLUENT DROP.

CONCRETE STORM WATER CONFLICT MANHOLE

PLATE S-9

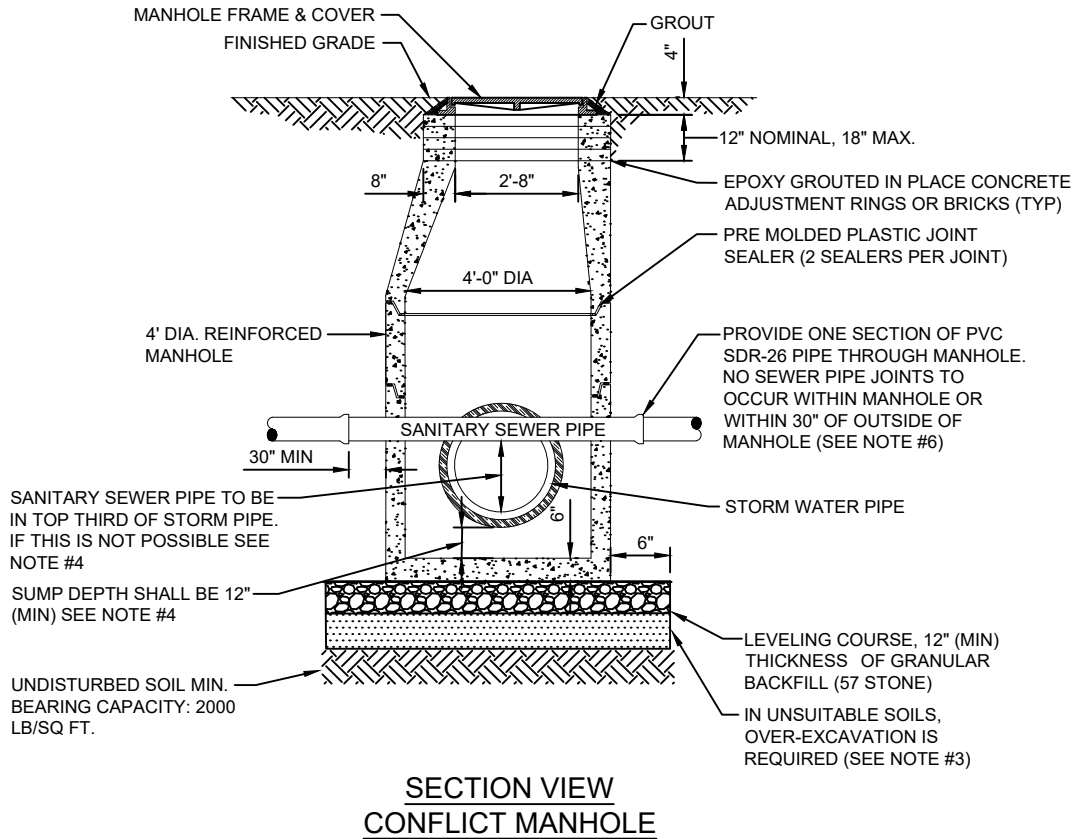

NOTES:

1. PRECAST MANHOLE SECTIONS TO BE MANUFACTURED IN ACCORDANCE WITH THE LATEST EDITIONS OF A.S.T.M. C-478 WITH 4000 LB. CONC., TYPE II CEMENT. ALL LIFTING HOLES AND OUTSIDE INSERTS SHALL BE FILLED WITH NON-SHRINK GROUT AND COATED WITH BITUMINOUS WATERPROOFING MATERIAL.
2. TYPE "E" MANHOLES ARE TO BE UTILIZED WHERE CONFLICT EXISTS BETWEEN STORM WATER PIPE AND SANITARY SEWER PIPES. THE USE OF THIS STYLE OF MANHOLE SHALL BE MINIMIZED WHERE POSSIBLE.
3. IN SILTS, CLAY OR HIGHLY ORGANIC SOILS (FINE-GRAINED SOILS INCLUDING SOIL GROUPS ML, CL, OL, MH, CH, OH AND PT) THE SOILS SHALL BE OVER-EXCAVATED AN ADDITIONAL 24" (AT A MIN.) AND BACKFILLED WITH AASHTO CLASS A-3 SOIL (COMPACTED TO 98%, ASTM D1557) OR OVER-EXCAVATE AN ADDITIONAL 12" (AT A MIN.) AND BACKFILL WITH GRANULAR BACKFILL (57 STONE).
4. IF THE GRAVITY SEWER PIPE IS LOCATED BELOW THE TOP THIRD OF THE STORM WATER PIPE, THEN THE SUMP DEPTH SHALL BE AS FOLLOWS:
 - a) FOR STORM PIPES 36" AND SMALLER, A 24" DEEP SUMP IS REQUIRED.
 - b) FOR STORM PIPES LARGER THAN 36", A 36" DEEP SUMP IS REQUIRED.
5. NO WATER MAIN, RECLAIMED WATER MAIN OR SEWER FORCE MAIN SHALL BE ALLOWED TO PENETRATE A STORM WATER STRUCTURE.
6. SPECIAL APPROVAL IS REQUIRED FOR GRAVITY SEWER PIPES 12" AND LARGER AND WILL BE CONSIDERED ON A CASE BY CASE BASIS. IF APPROVED, CONSTRUCTION DETAILS MAY BE REQUIRED.
7. SEAL ALL EXTERIOR JOINTS PER PLATE S-17

POLYMER STORM WATER CONFLICT MANHOLE PLATE S-9A

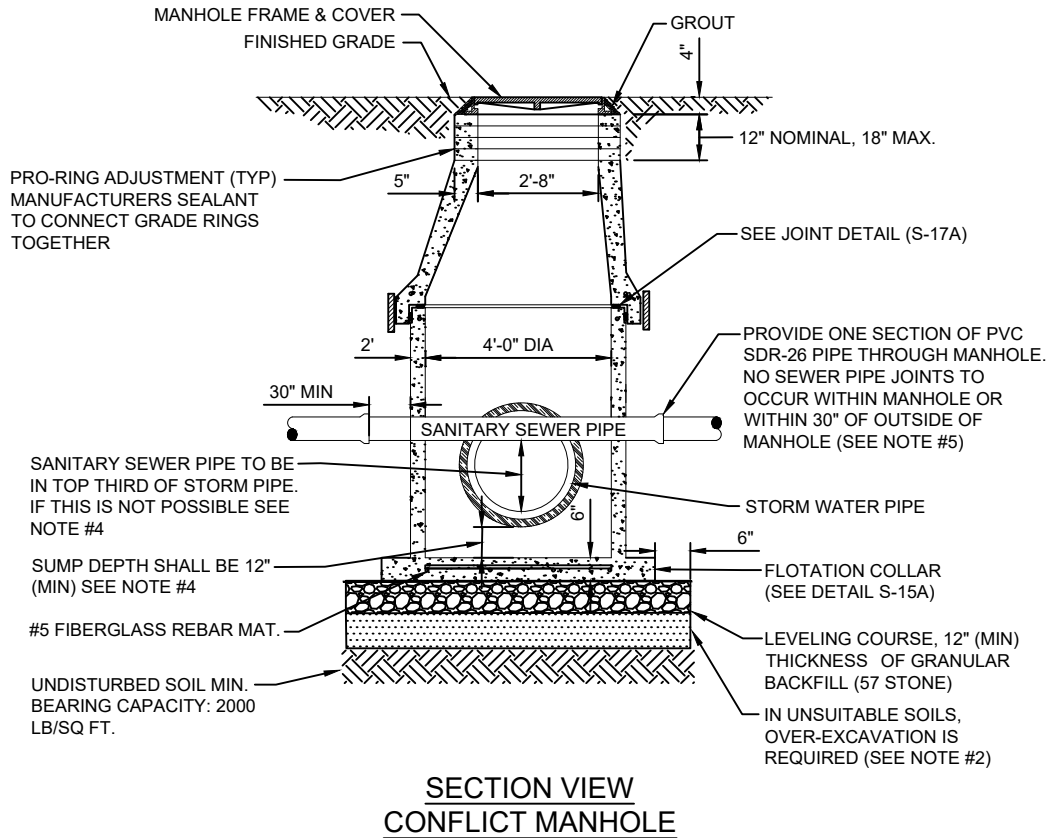

NOTES:

1. TYPE "E" MANHOLES ARE TO BE UTILIZED WHERE CONFLICT EXISTS BETWEEN STORM WATER PIPE AND SANITARY SEWER PIPES. THE USE OF THIS STYLE OF MANHOLE SHALL BE MINIMIZED WHERE POSSIBLE.
2. IN SILTS, CLAY OR HIGHLY ORGANIC SOILS (FINE-GRAINED SOILS INCLUDING SOIL GROUPS ML, CL, OL, MH, CH, OH AND PT) THE SOILS SHALL BE OVER-EXCAVATED AN ADDITIONAL 24" (AT A MIN.) AND BACKFILLED WITH AASHTO CLASS A-3 SOIL (COMPACTED TO 98%, ASTM D1557) OR OVER-EXCAVATE AN ADDITIONAL 12" (AT A MIN.) AND BACKFILL WITH GRANULAR BACKFILL (57 STONE).
3. IF THE GRAVITY SEWER PIPE IS LOCATED BELOW THE TOP THIRD OF THE STORM WATER PIPE, THEN THE SUMP DEPTH SHALL BE AS FOLLOWS:
 - a) FOR STORM PIPES 36" AND SMALLER, A 24" DEEP SUMP IS REQUIRED.
 - b) FOR STORM PIPES LARGER THAN 36", A 36" DEEP SUMP IS REQUIRED.
4. NO WATER MAIN, RECLAIMED WATER MAIN OR SEWER FORCE MAIN SHALL BE ALLOWED TO PENETRATE A STORM WATER STRUCTURE.
5. SPECIAL APPROVAL IS REQUIRED FOR GRAVITY SEWER PIPES 12" AND LARGER AND WILL BE CONSIDERED ON A CASE BY CASE BASIS. IF APPROVED, CONSTRUCTION DETAILS MAY BE REQUIRED.
6. SEAL ALL EXTERIOR JOINTS PER PLATE S-17A

SANITARY SEWER POLYMER TYPE "F" MANHOLE 12"-21" SEWERS

PLATE S-10A

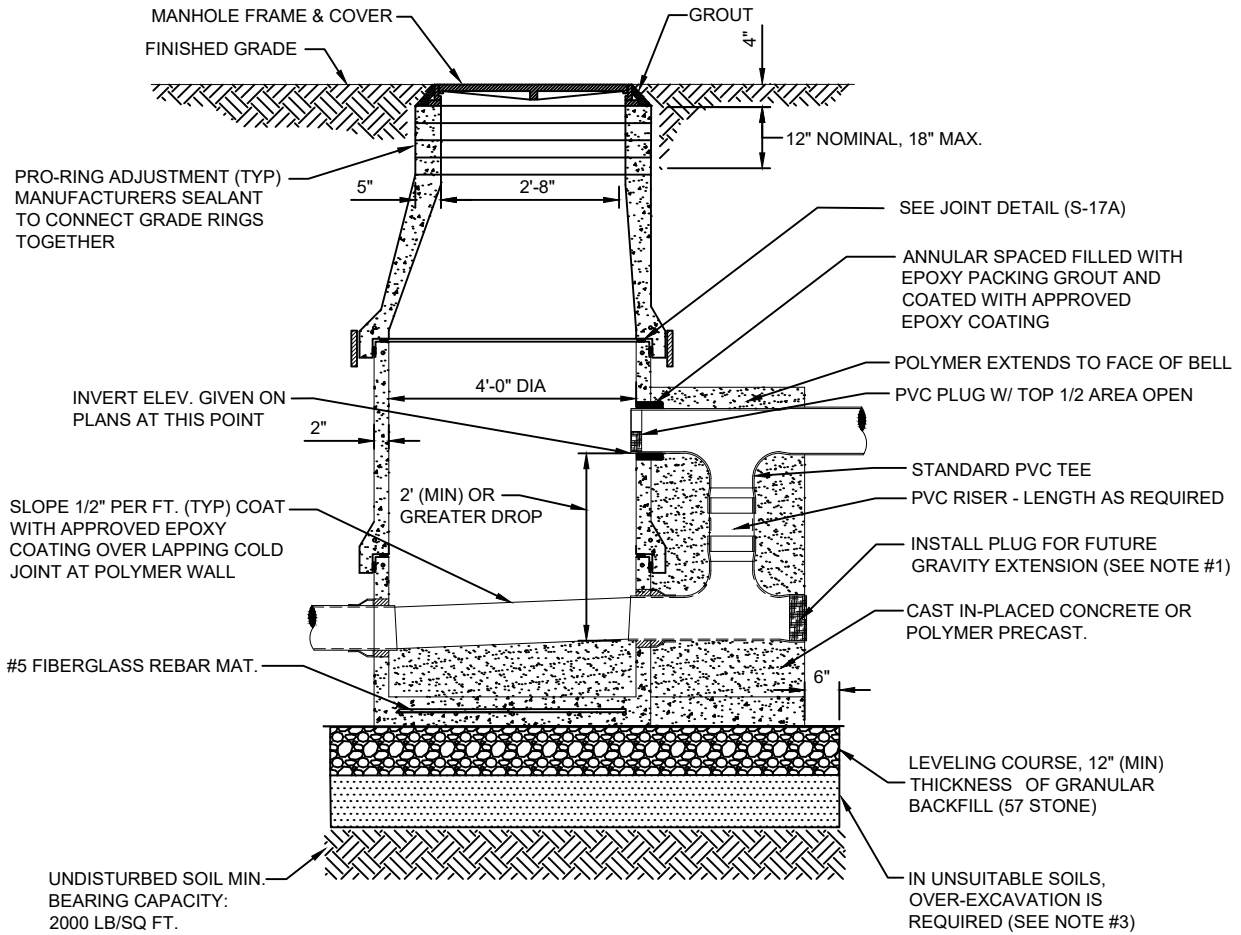

NOTES:

1. TYPE "F" MANHOLE SHALL BE USED FOR 12" OR LARGER INFLUENT PIPES W/ 2' OR GREATER INFLUENT DROP THIS MANHOLE IS TO BE USED WHERE THE INFLUENT GRAVITY LINE IS TO BE EXTENDED IN THE FUTURE (SEE DETAIL).
2. SEAL ALL EXTERIOR JOINTS PER PLATE S-17A
3. IN SILTS, CLAY OR HIGHLY ORGANIC SOILS (FINE-GRAINED SOILS INCLUDING SOIL GROUPS ML, CL, OL, MH, CH, OH AND PT) THE SOILS SHALL BE OVER-EXCAVATED AN ADDITIONAL 24" (AT A MIN.) AND BACKFILLED WITH AASHTO CLASS A-3 SOIL (COMPACTED TO 98%, ASTM D1557) OR OVER-EXCAVATE AN ADDITIONAL 12" (AT A MIN.) AND BACKFILL WITH GRANULAR BACKFILL (57 STONE).

SANITARY SEWER CONCRETE TYPE "G" MANHOLE 24" - 60" SEWERS

PLATE S-11

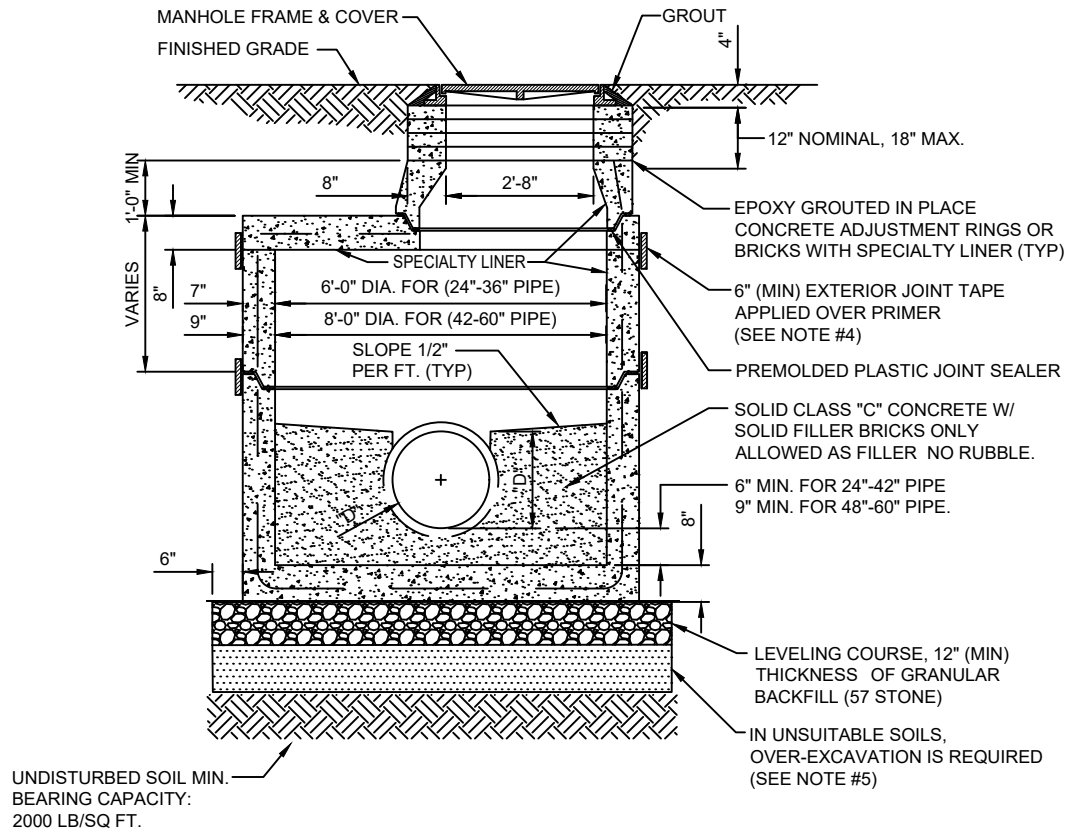

NOTES:

1. PRECAST MANHOLE SECTIONS TO BE MANUFACTURED IN ACCORDANCE WITH THE LATEST EDITIONS OF A.S.T.M. C-478 WITH 4000 LB. CONC., TYPE II CEMENT. ALL LIFTING HOLES AND OUTSIDE INSERTS SHALL BE FILLED WITH NON-SHRINK GROUT AND COATED WITH BITUMINOUS WATERPROOFING MATERIAL.
2. THE EXTERIOR ONLY OF MANHOLE SHALL BE GIVEN TWO COATS OF BITUMINOUS WATERPROOFING MATERIAL.
3. SPECIALTY LINER IS TO BE INSTALLED ON INSIDE SURFACE OF MANHOLE IN ACCORDANCE WITH AS-602, THEREFORE, THE BITUMINOUS WATERPROOFING SHALL BE OMITTED ON INSIDE.
4. SEAL ALL EXTERIOR JOINTS PER PLATE S-17
5. IN SILTS, CLAY OR HIGHLY ORGANIC SOILS (FINE-GRAINED SOILS INCLUDING SOIL GROUPS ML, CL, OL, MH, CH, OH AND PT) THE SOILS SHALL BE OVER-EXCAVATED AN ADDITIONAL 24" (AT A MIN.) AND BACKFILLED WITH AASHTO CLASS A-3 SOIL (COMPACTED TO 98%, ASTM D1557) OR OVER-EXCAVATE AN ADDITIONAL 12" (AT A MIN.) AND BACKFILL WITH GRANULAR BACKFILL (57 STONE).

SANITARY SEWER CONCRETE TYPE "H" MANHOLE 24" - 60" SEWERS

PLATE S-12

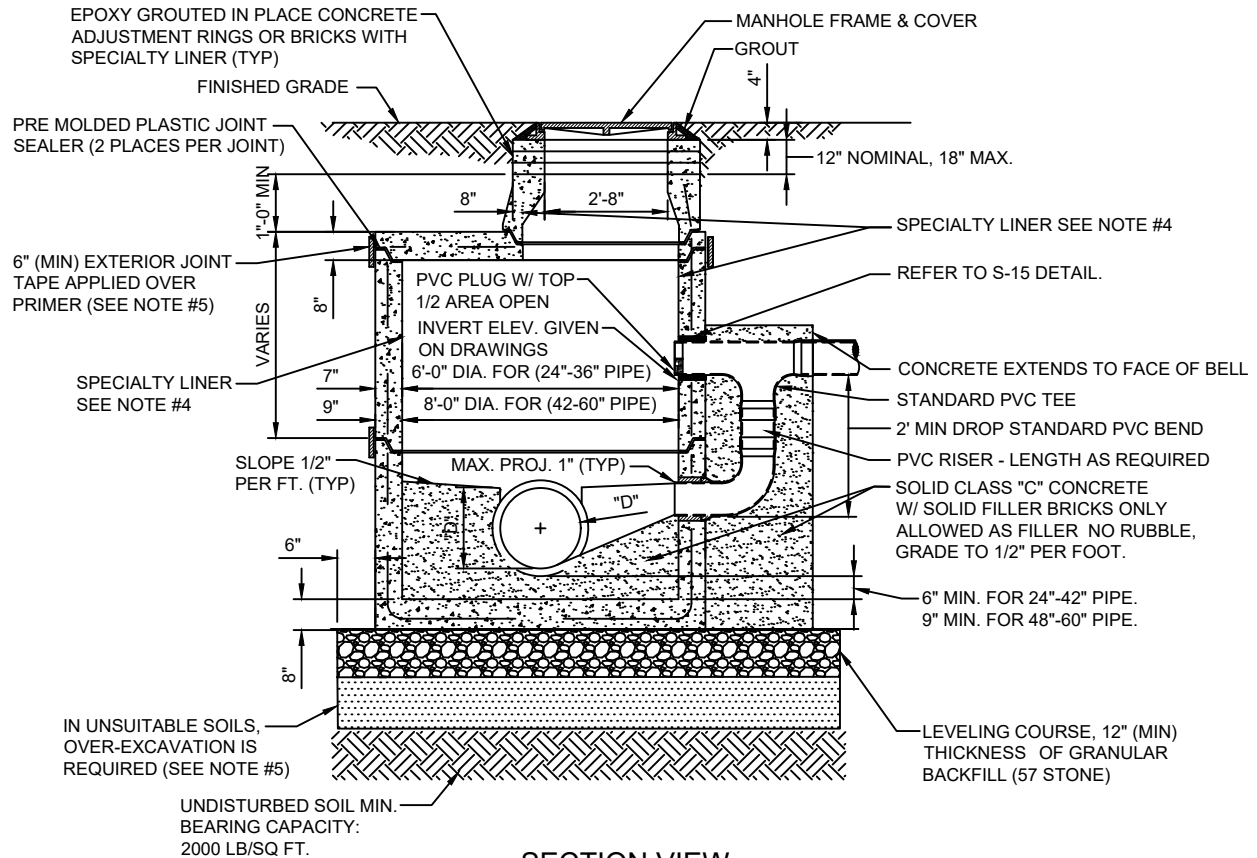

SECTION VIEW

NOTES:

1. PRECAST MANHOLE SECTIONS TO BE MANUFACTURED IN ACCORDANCE WITH THE LATEST EDITIONS OF A.S.T.M. C-478 WITH 4000 LB. CONC., TYPE II CEMENT. ALL LIFTING HOLES AND OUTSIDE INSERTS SHALL BE FILLED WITH NON-SHRINK GROUT AND COATED WITH BITUMINOUS WATERPROOFING MATERIAL.
2. THE EXTERIOR OF MANHOLE SHALL BE GIVEN TWO COATS OF BITUMINOUS WATERPROOFING MATERIAL.
3. OUTSIDE DROPS REQUIRED IF DROPS ARE 2' OR GREATER.
4. SPECIALTY LINER IS TO BE INSTALLED ON INSIDE SURFACE OF MANHOLE IN ACCORDANCE WITH AS-602, THEREFORE, THE BITUMINOUS WATERPROOFING SHALL BE OMITTED ON INSIDE. SEE SPECIFICATIONS FOR APPROVED SPECIALTY LINERS.
5. SEAL ALL EXTERIOR JOINTS PER PLATE S-17
6. IN SILTS, CLAY OR HIGHLY ORGANIC SOILS (FINE-GRAINED SOILS INCLUDING SOIL GROUPS ML, CL, OL, MH, CH, OH AND PT) THE SOILS SHALL BE OVER-EXCAVATED AN ADDITIONAL 24" (AT A MIN.) AND BACKFILLED WITH AASHTO CLASS A-3 SOIL (COMPACTED TO 98%, ASTM D1557) OR OVER-EXCAVATE AN ADDITIONAL 12" (AT A MIN.) AND BACKFILL WITH GRANULAR BACKFILL (57 STONE).

SANITARY SEWER CONCRETE TYPE "I" MANHOLE 24" - 60" SEWERS

PLATE S-13

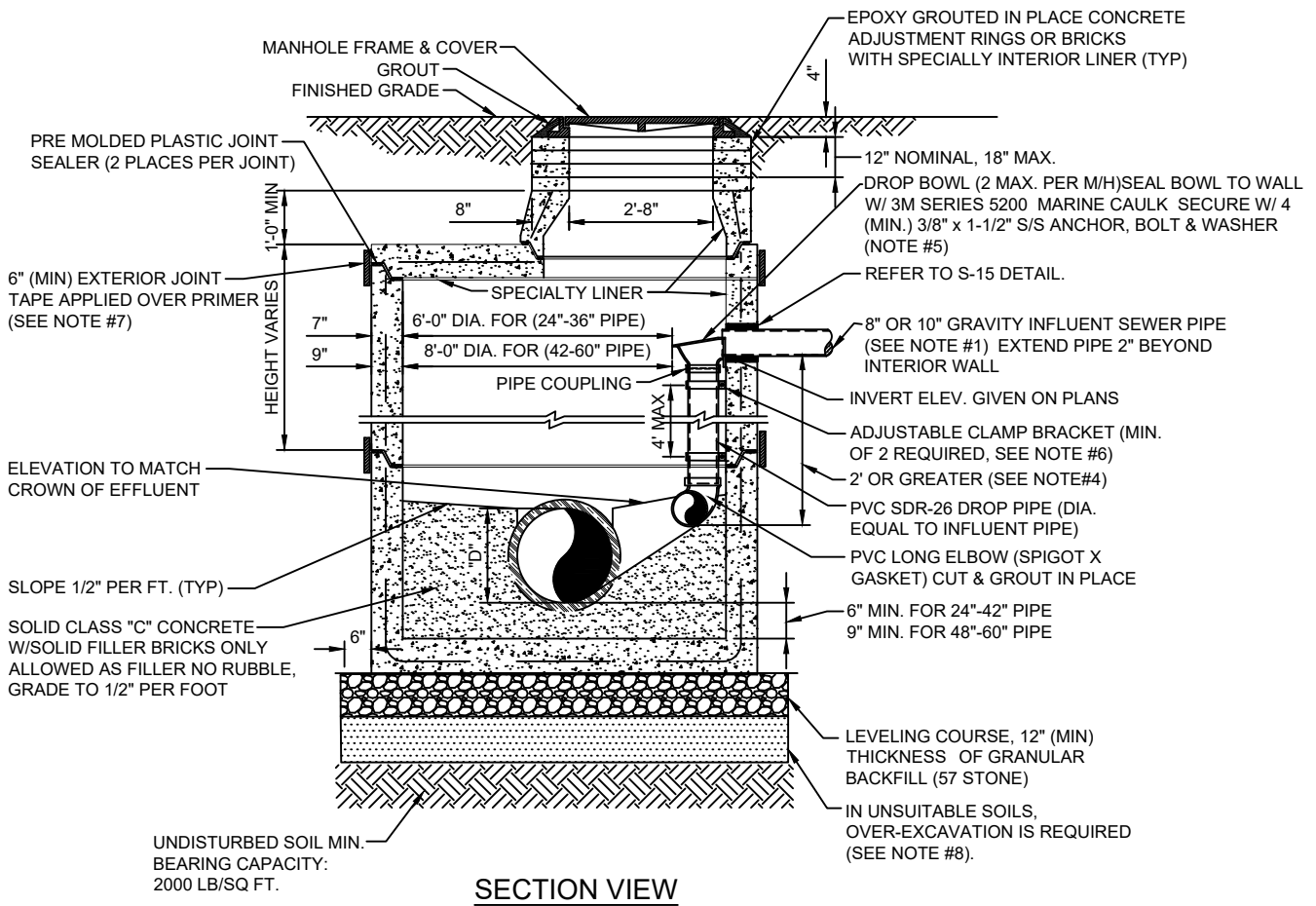

NOTES:

1. THIS ASSEMBLY IS FOR 8" OR 10" GRAVITY INFLUENT LINES ONLY. NO DROPS ALLOWED FOR FORCE MAINS. DROP BOWL BY RELINER OR APPROVED EQUAL REQUIRED.
2. PRECAST MANHOLE SECTIONS TO BE MANUFACTURED IN ACCORDANCE WITH THE LATEST EDITIONS OF A.S.T.M. C-478 WITH 4000 LB. CONC., TYPE II CEMENT. ALL LIFTING HOLES AND OUTSIDE INSERTS SHALL BE FILLED WITH NON-SHRINK GROUT AND COATED WITH BITUMINOUS WATERPROOFING MATERIAL.
3. THE EXTERIOR OF THE MANHOLE AND INTERIOR OF ADJUSTMENT RINGS SHALL BE GIVEN TWO COATS OF BITUMINOUS WATERPROOFING MATERIAL.
4. THIS DETAIL FOR 2' OR GREATER ELEVATIONS DIFFERENCE BETWEEN INVERT OF INCOMING PIPE AND ELBOW OUTLET.
5. THE DROP BOWL ASSEMBLY SHALL BE INSTALLED PRIOR TO APPLICATION OF SPECIALTY LINING MATERIAL IN ACCORDANCE WITH AS-602, THEREFORE, BITUMINOUS WATERPROOFING MATERIAL SHALL BE OMITTED FROM THE INSIDE OF MANHOLE. SEE SPECIFICATIONS FOR THE INSTALLATION OF SPECIALTY LINING MATERIAL SECTION 446.
6. ADJUSTABLE CLAMPING BRACKET (MIN. 2 PER DROP BOWL ASSY). 1-1/2" WIDE, 11 GA. W/ 3/8" DIA. 18-8 PINCH BOLTS AND NUTS. SECURE TO M/H WALL WITH (2) 3/8" X 1" BOLT, ANCHOR & WASHER PER BRACKET ASSY. ALL 304 OR 316 STAINLESS STEEL MATERIALS.
7. SEAL ALL EXTERIOR JOINTS PER PLATE S-17
8. IN SILTS, CLAY OR HIGHLY ORGANIC SOILS (FINE-GRAINED SOILS INCLUDING SOIL GROUPS ML, CL, OL, MH, CH, OH AND PT) THE SOILS SHALL BE OVER-EXCAVATED AN ADDITIONAL 24" (AT A MIN.) AND BACKFILLED WITH AASHTO CLASS A-3 SOIL (COMPACTED TO 98%, ASTM D1557) OR OVER-EXCAVATE AN ADDITIONAL 12" (AT A MIN.) AND BACKFILL WITH GRANULAR BACKFILL (57 STONE).

SANITARY SEWER POLYMER TYPE "I" MANHOLE 24" - 60" SEWERS

PLATE S-13A

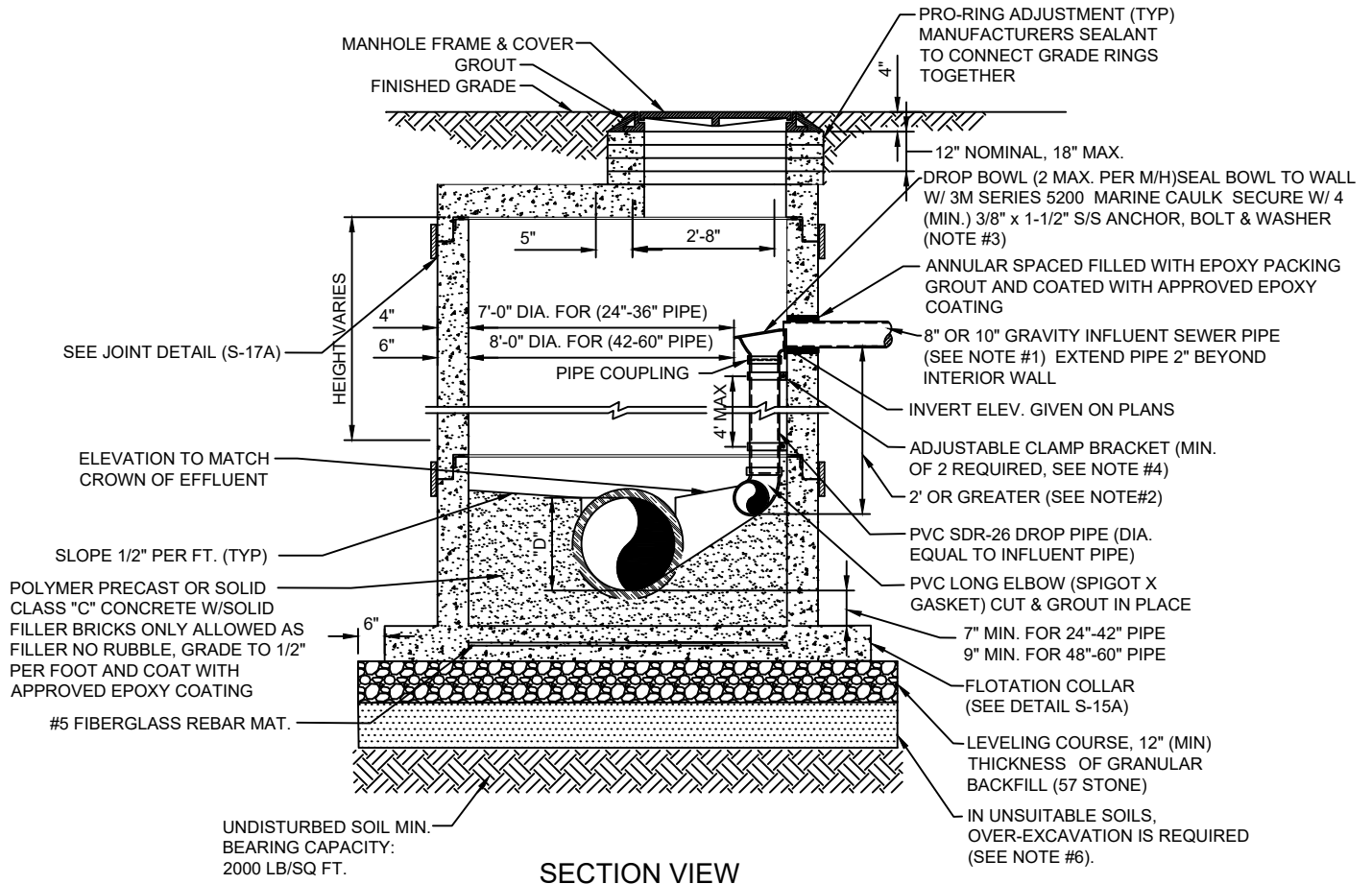

NOTES:

1. THIS ASSEMBLY IS FOR 8" OR 10" GRAVITY INFLUENT LINES ONLY. NO DROPS ALLOWED FOR FORCE MAINS. DROP BOWL BY RELINER OR APPROVED EQUAL REQUIRED.
2. THIS DETAIL FOR 2' OR GREATER ELEVATIONS DIFFERENCE BETWEEN INVERT OF INCOMING PIPE AND ELBOW OUTLET.
3. ADJUSTABLE CLAMPING BRACKET (MIN. 2 PER DROP BOWL ASSY). 1-1/2" WIDE, 11 GA. W/ 3/8" DIA. 18-8 PINCH BOLTS AND NUTS. SECURE TO M/H WALL WITH (2) 3/8" X 1" BOLT, ANCHOR & WASHER PER BRACKET ASSY. ALL 304 OR 316 STAINLESS STEEL MATERIALS.
4. SEAL ALL EXTERIOR JOINTS PER PLATE S-17A
5. IN SILTS, CLAY OR HIGHLY ORGANIC SOILS (FINE-GRAINED SOILS INCLUDING SOIL GROUPS ML, CL, OL, MH, CH, OH AND PT) THE SOILS SHALL BE OVER-EXCAVATED AN ADDITIONAL 24" (AT A MIN.) AND BACKFILLED WITH AASHTO CLASS A-3 SOIL (COMPACTED TO 98%, ASTM D1557) OR OVER-EXCAVATE AN ADDITIONAL 12" (AT A MIN.) AND BACKFILL WITH GRANULAR BACKFILL (57 STONE).

FIBERGLASS MANHOLE

PLATE S-14

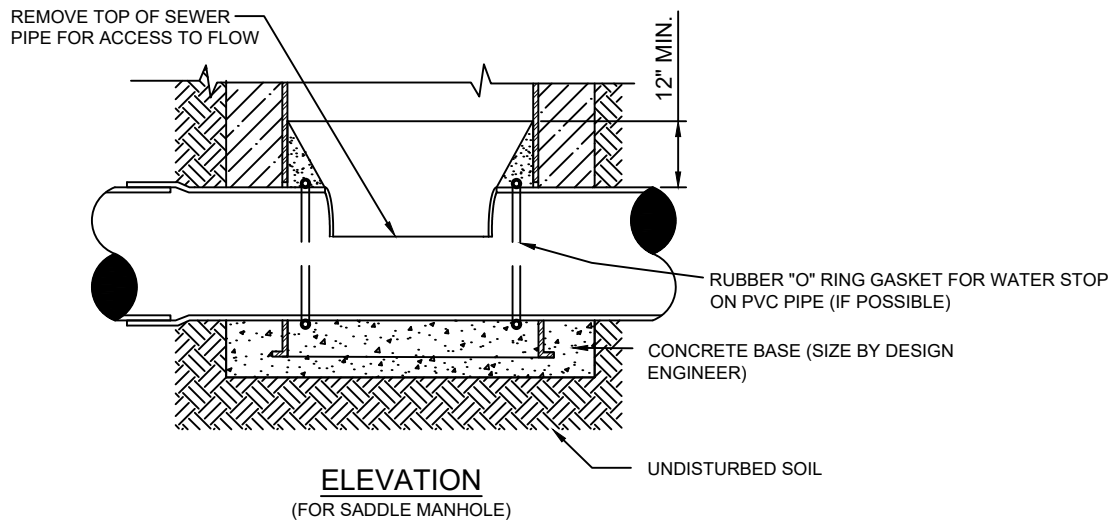
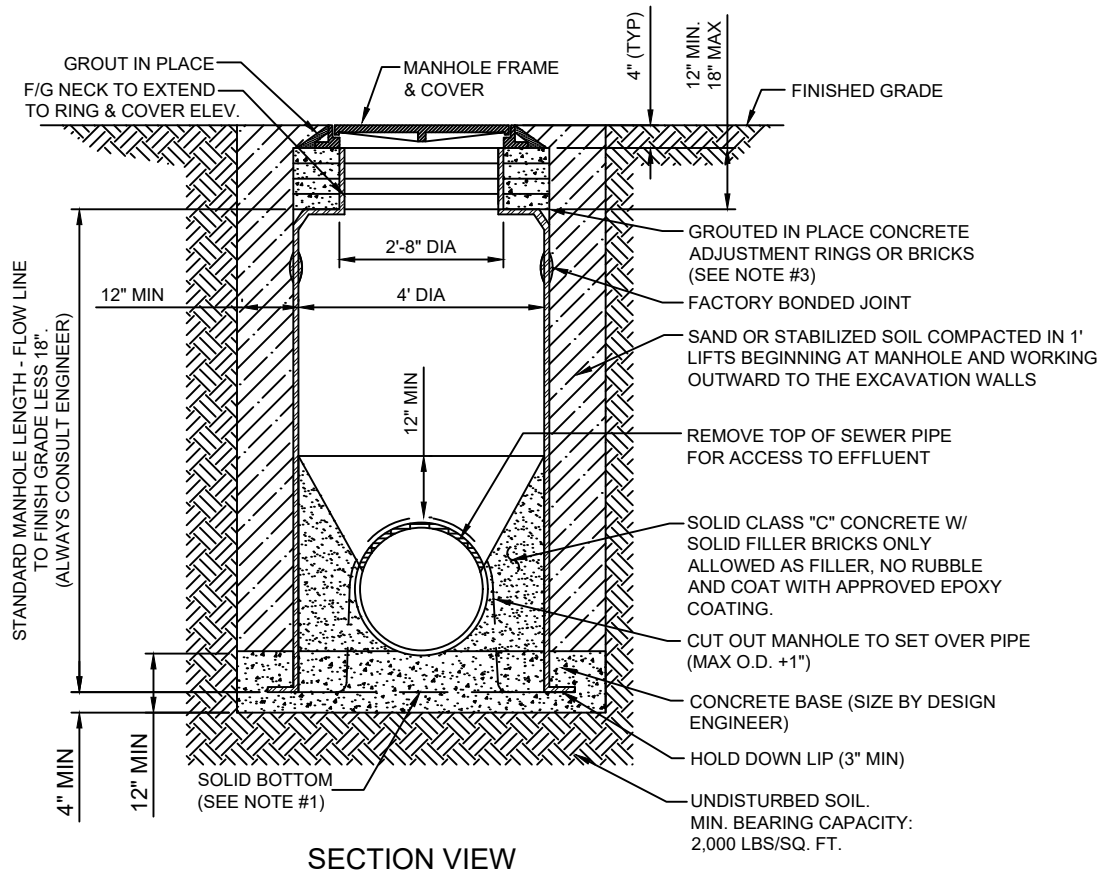

NOTES:

1. A STANDARD TYPE "A" MANHOLE SHALL INCLUDE A SOLID BOTTOM WITH 3" HOLD DOWN FLANGE.
2. CONCRETE BASE TO BE SIZE BY ENGINEER. THE MINIMUM SIZE IS SHOWN ABOVE.
3. IF EXPOSED, THE INTERIOR OF CONCRETE ADJUSTING RINGS WILL BE GIVEN 2 COATS OF BITUMINOUS WATERPROOFING MATERIAL.
4. SEAL ALL EXTERIOR JOINTS PER PLATE S-17

POLYMER "DOG HOUSE" MANHOLE

PLATE S-14A

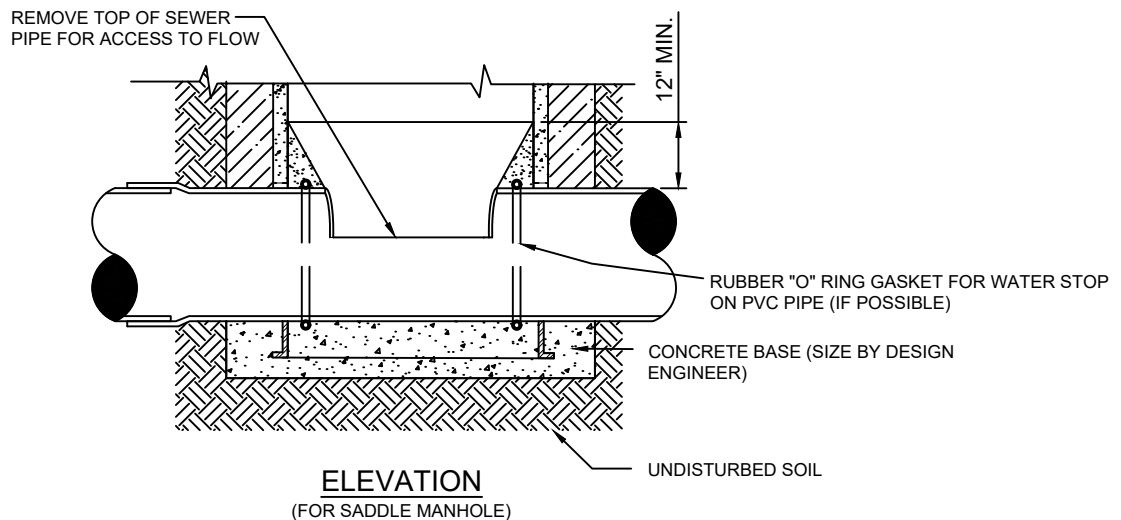
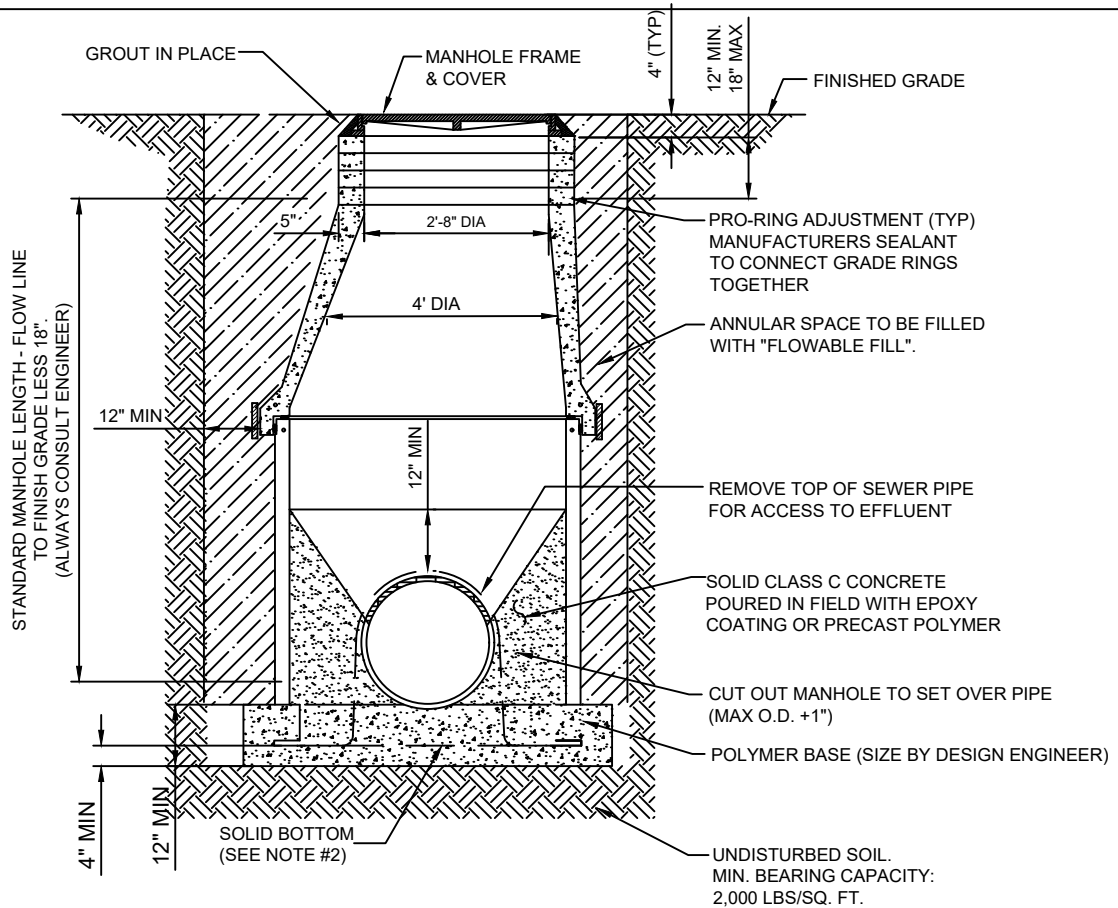

NOTES:

1. TO BE USED IN LIMITED SCENARIOS WITH SPECIAL APPROVAL FROM JEA.
2. A STANDARD TYPE "A" MANHOLE SHALL INCLUDE A SOLID BOTTOM WITH 3" HOLD DOWN FLANGE.
3. CONCRETE BASE TO BE SIZE BY ENGINEER. THE MINIMUM SIZE IS SHOWN ABOVE.
4. SEAL ALL EXTERIOR JOINTS PER PLATE S-17A

POLYMER REHAB BASE AND RISER MANHOLE

PLATE S-14B

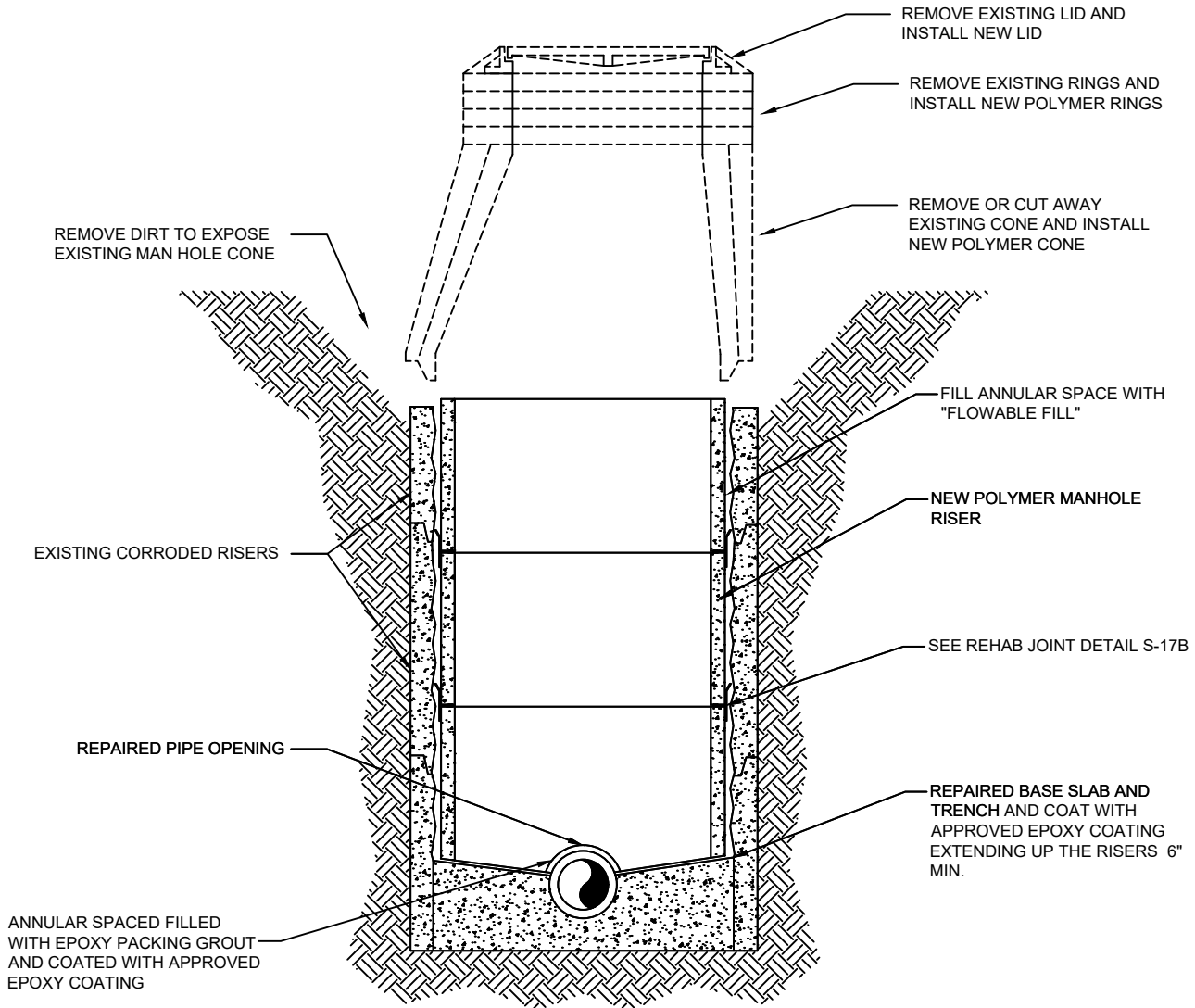

SECTION VIEW

NOTES:

1. AFTER INSTALLING THE BASE POLYMER BASE AND RISER ATTACHED GUIDE AND ADD ADDITIONAL RISERS AS REQUIRED.
2. CONTRACTOR SHALL FOLLOW ALL CONFINED SPACE REGULATIONS AND PROSECUTES.
3. FILL ANNULAR SPACE BETWEEN THE OLD AND NEW MANHOLE WITH "FLOWABLE FILL" AND BACK FILL AS REQUIRED TO EXISTING GRADE.
4. SEAL ALL EXTERIOR JOINTS PER PLATE S-17A

CONCRETE AND POLYMER MANHOLE PIPE CONNECTION DETAILS

PLATE S-15

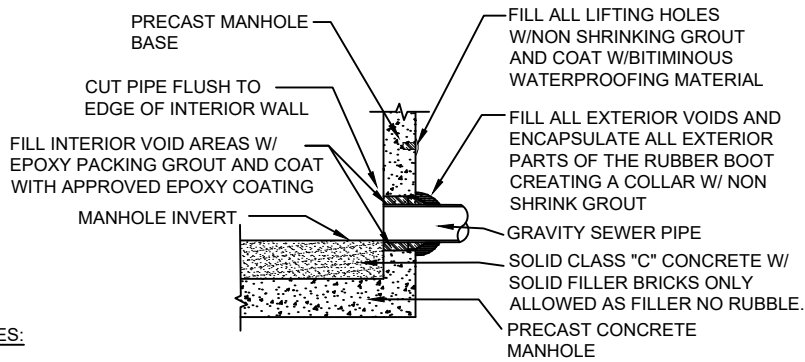

NOTES:

1. RUBBER BOOT, DOUBLE BANDED, 316 S/S CLAMPS, MEETING THE ASTM C923 STANDARD.
2. SEE RUBBER BOOT DETAIL BELOW.

RUBBER BOOT

(FOR NEW M/H CONSTRUCTION ONLY, MAXIMUM DEPTH 15FT)

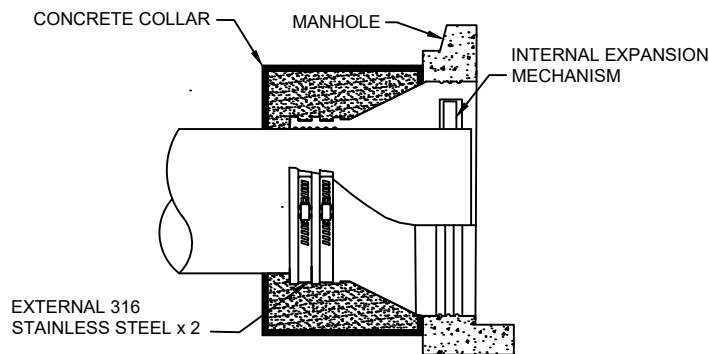

RUBBER BOOT DETAIL

(FOR EXISTING AND NEW M/H CONSTRUCTION)

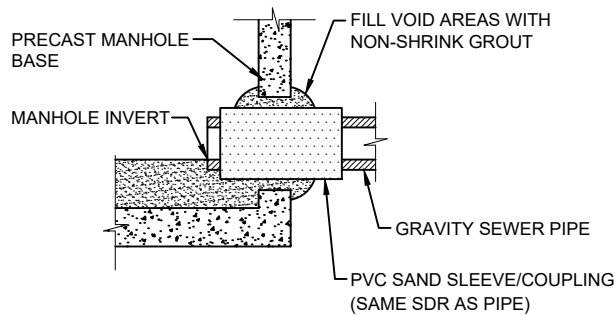

PVC SAND SLEEVE

(FOR EXISTING AND NEW M/H CONSTRUCTION)

MANHOLE BOTTOM DETAILS

PLATE S-15A

POLYMER CONCRETE FLOATATION COLLARS						
	DEPTH 0-10FT		DEPTH 11-15FT		DEPTH 16-20FT	
DIAMETER	MINIMUM BASE EXTENDER (IN)	MINIMUM WEIGHT OF TOTAL STRUCTURE (LBS)	MINIMUM BASE EXTENDER (IN)	MINIMUM WEIGHT OF TOTAL STRUCTURE (LBS)	MINIMUM BASE EXTENDER (IN)	MINIMUM WEIGHT OF TOTAL STRUCTURE (LBS)
48	2	7801	-	6101	-	7701
60	2	10000	1	11500	-	10400
72	3	16500	3	17300	1	18900
84	3	24700	3	27000	2	30600
96	3	35600	3	37600	2	46600

NOTES:

1. BUOYANCY FACTOR OF SAFETY = 1.2
2. ASSUMED LID THICKNESS = 8IN
3. MANHOLES ASSUMED TO BE STRAIGHT WITH NO REDUCER
4. GROUND WATER LEVEL ASSUMED TO BE AT SURFACE

FLOTATION COLLAR

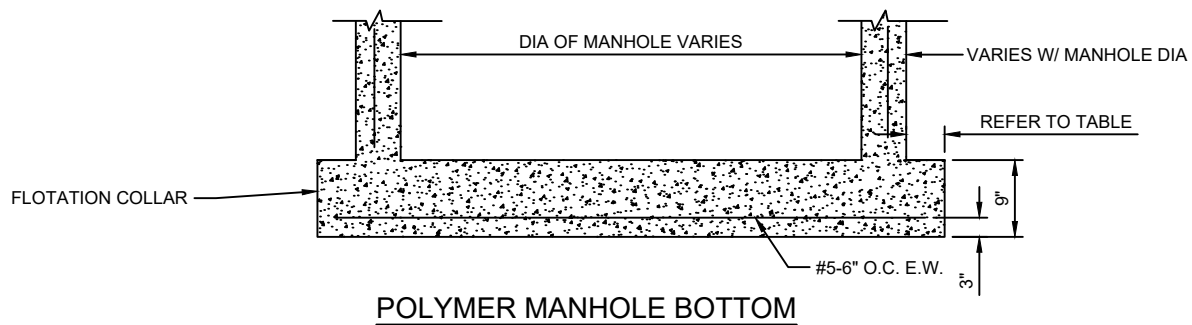

POLYMER MANHOLE BOTTOM

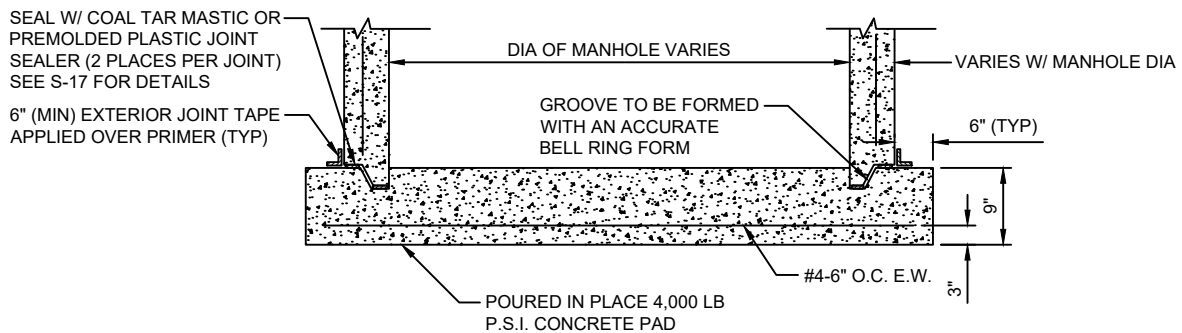

NOTES:

THE USE OF THE POURED IN PLACE MANHOLE BOTTOM SHALL BE MINIMIZED AND SHALL BE SPECIFICALLY APPROVED BY JEA PRIOR TO CONSTRUCTION.

CONCRETE MANHOLE BOTTOM

MISCELLANEOUS MANHOLE CONNECTIONS

PLATE S-16

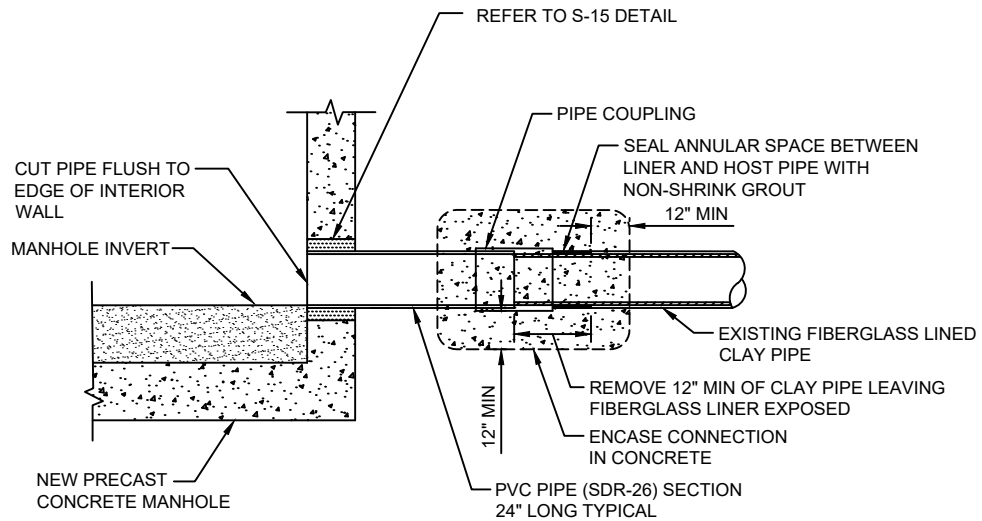

EXISTING CLAY PIPE WITH LINER

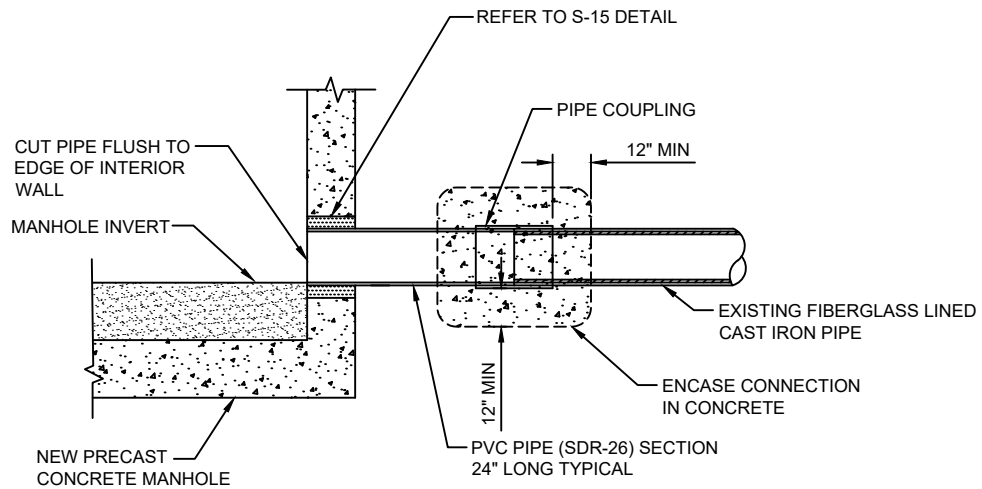

EXISTING CAST IRON PIPE WITH LINER

PRECAST CONCRETE SEWER MANHOLE JOINT DETAIL

PLATE S-17

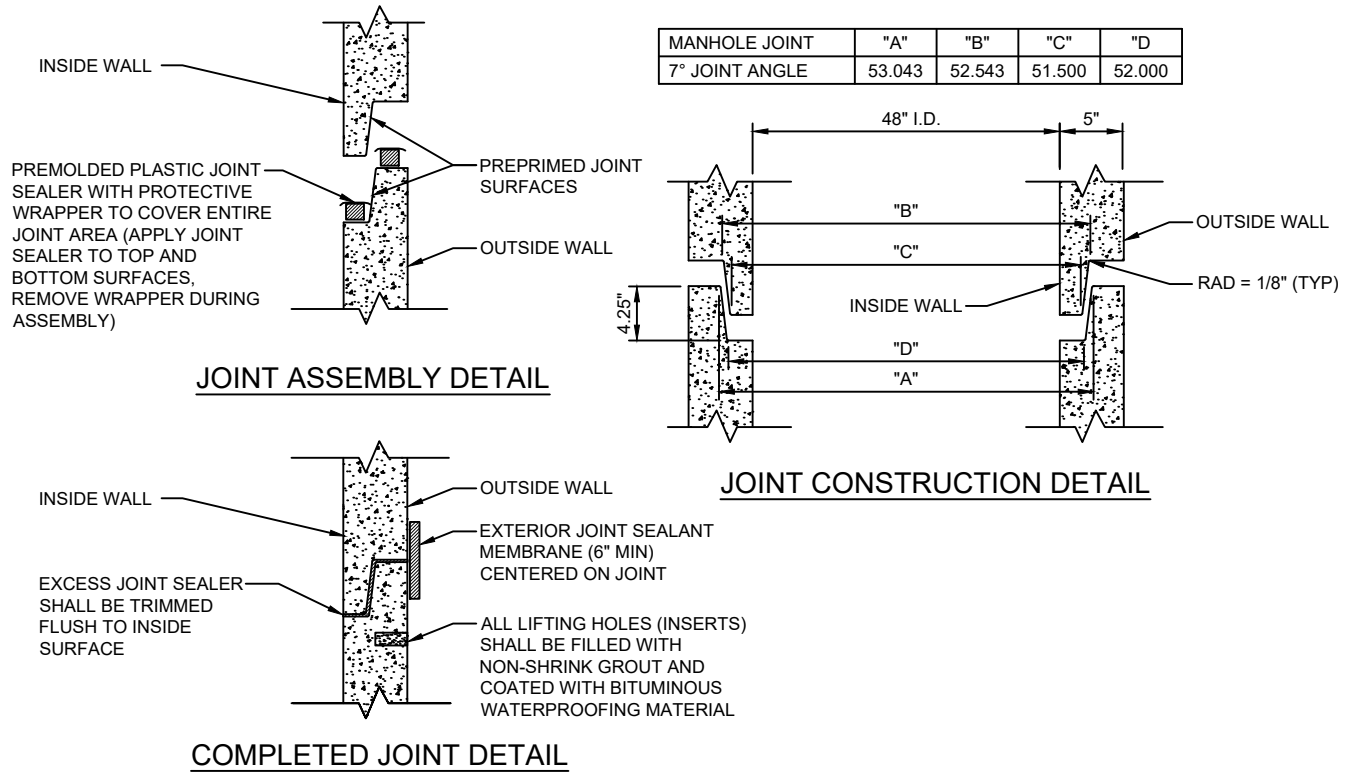

NOTES

ALL EXTERIOR MANHOLE JOINTS, INCLUDING BASE, RISER, AND CONE SECTIONS, AS WELL AS ADJUSTING RINGS TO BE SEALED IN ACCORDANCE WITH WATER AND WASTEWATER STANDARDS, SECTION 427 - WASTEWATER MANHOLES

PRECAST POLYMER SEWER MANHOLE JOINT DETAIL

PLATE S-17A

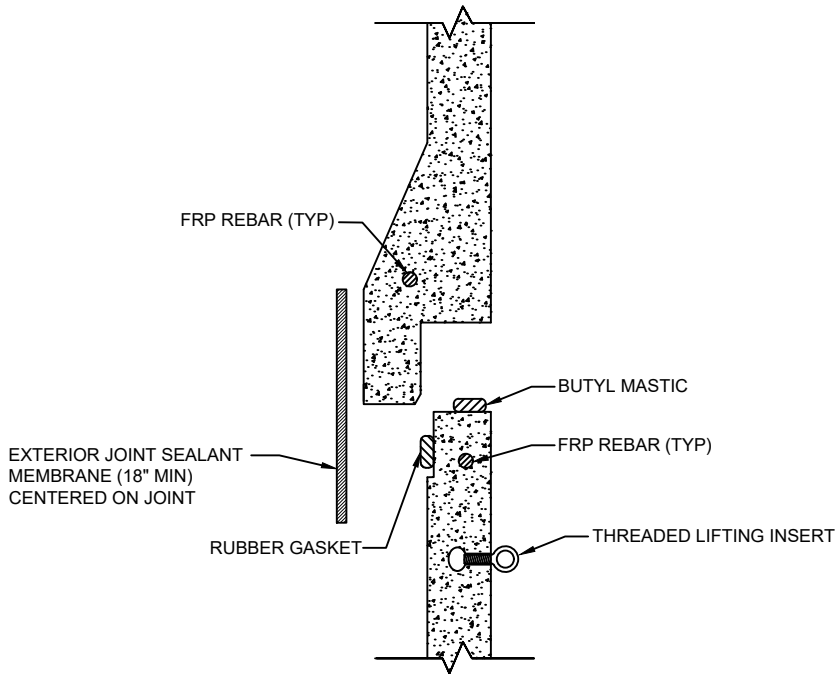

48"-72" JOINT DETAIL

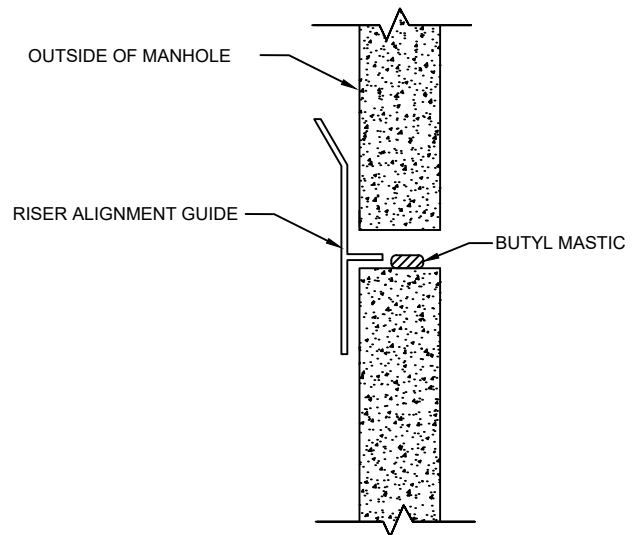

REHAB JOINT DETAIL

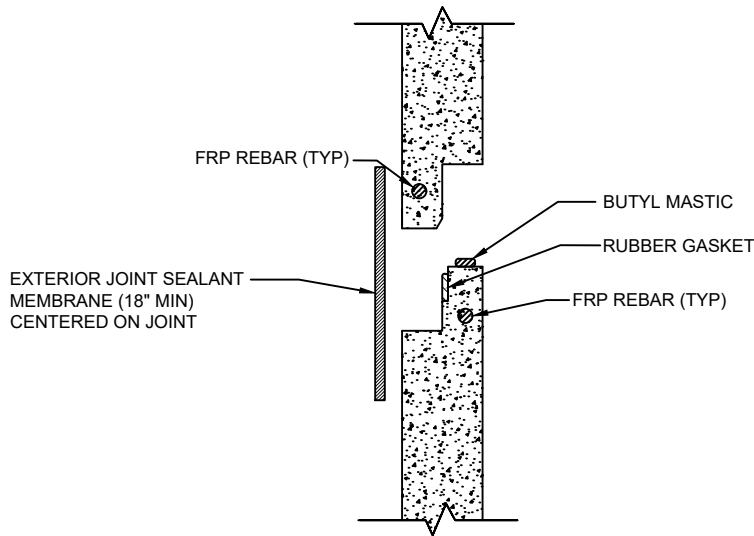

84"-144" JOINT DETAIL

NOTES

ALL EXTERIOR MANHOLE JOINTS, INCLUDING BASE, RISER, AND CONE SECTIONS, AS WELL AS ADJUSTING RINGS TO BE SEALED IN ACCORDANCE WITH WATER AND WASTEWATER STANDARDS, SECTION 427 - WASTEWATER MANHOLES

TYPICAL FORCE MAIN CONNECTION TO MANHOLE

PLATE S-18

NOTE:
ANGLE BETWEEN INFLUENT FORCE
MAIN AND GRAVITY EFFLUENT PIPE
SHALL BE BETWEEN 135° - 225° UNLESS
APPROVED OTHERWISE BY JEA.

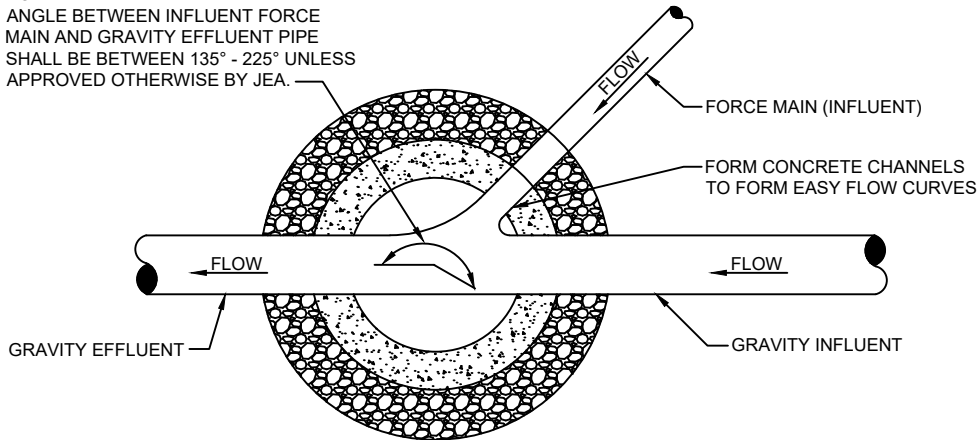

PLAN

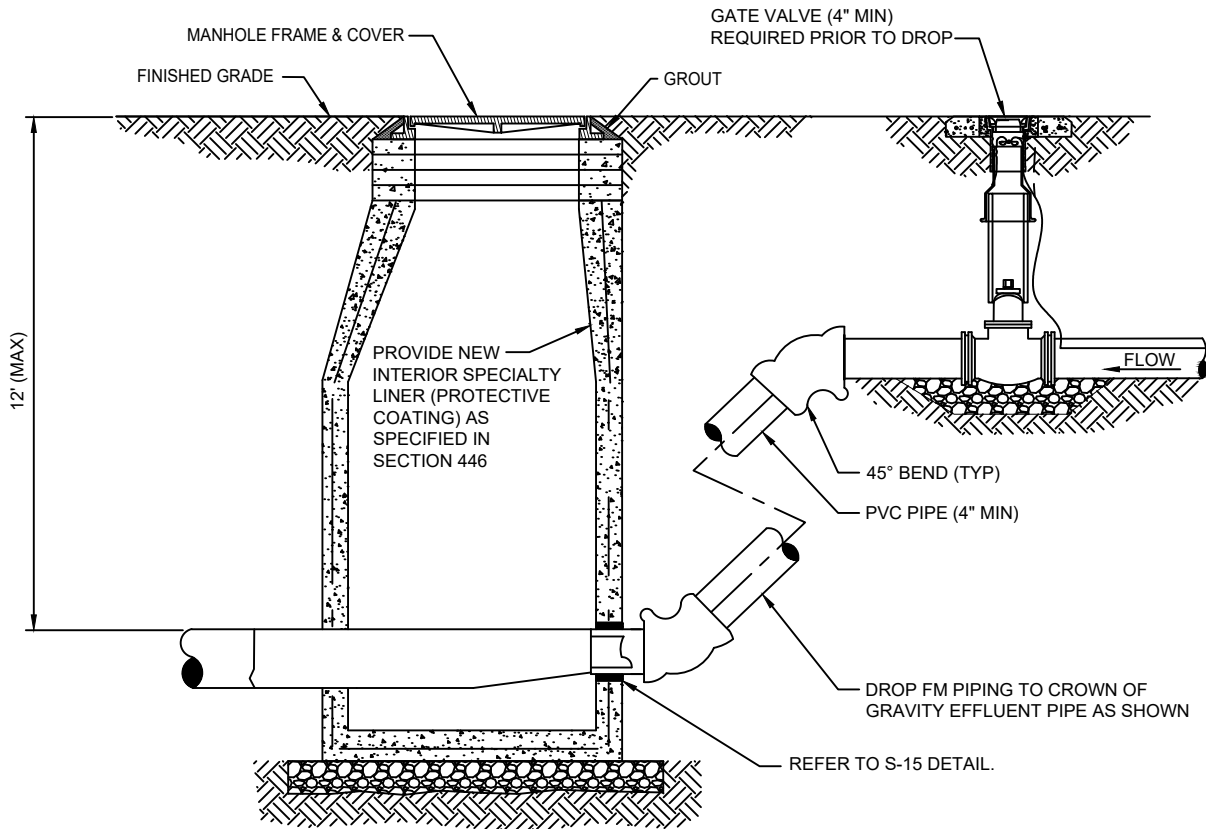

SECTION

MANHOLE FRAME AND COVER ADJUSTMENT
AFTER ROADWAY RE-SURFACING
PLATE S-34

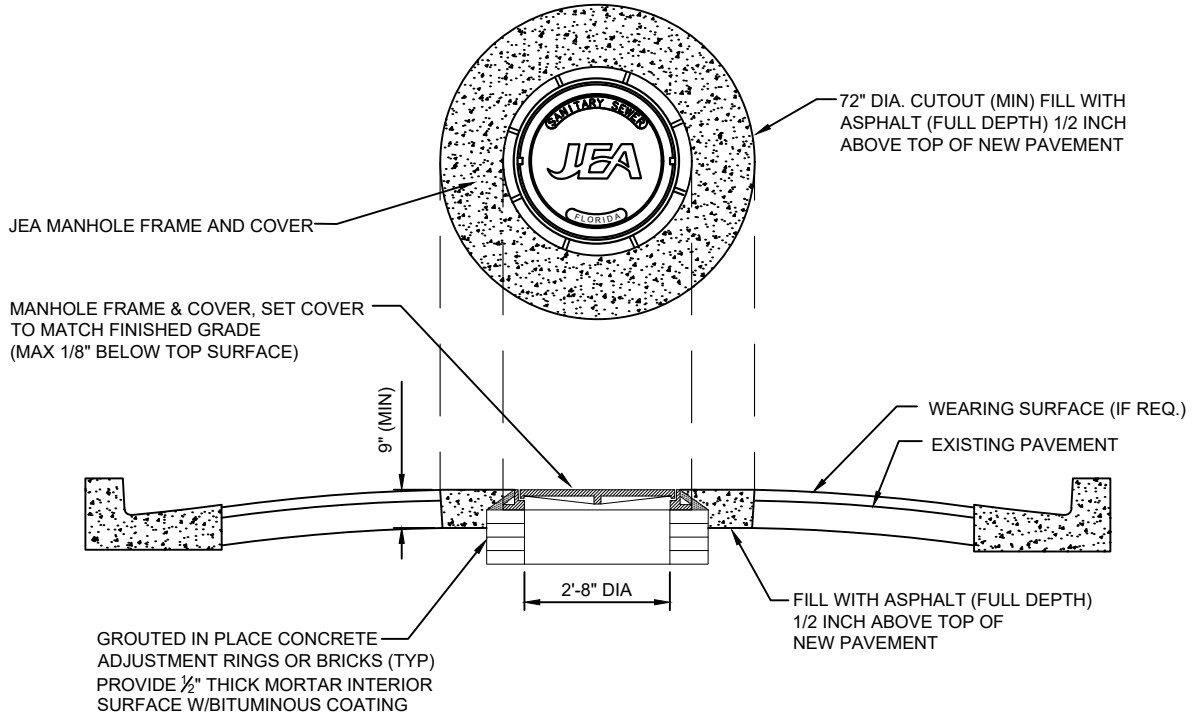

NOTES :

1. PROVIDE FULL DEPTH ASPHALT 1/2 INCH ABOVE TOP OF NEW PAVEMENT LEVEL, TO ALLOW FOR FUTURE ASPHALT MATERIAL COMPACTION. PLACE AND COMPACT ASPHALT IN 2" (MAX) LIFTS.

OPEN CUT TRENCH FOR PRESSURE PIPE IN CITY RIGHT -OF-WAY

PLATE S-55

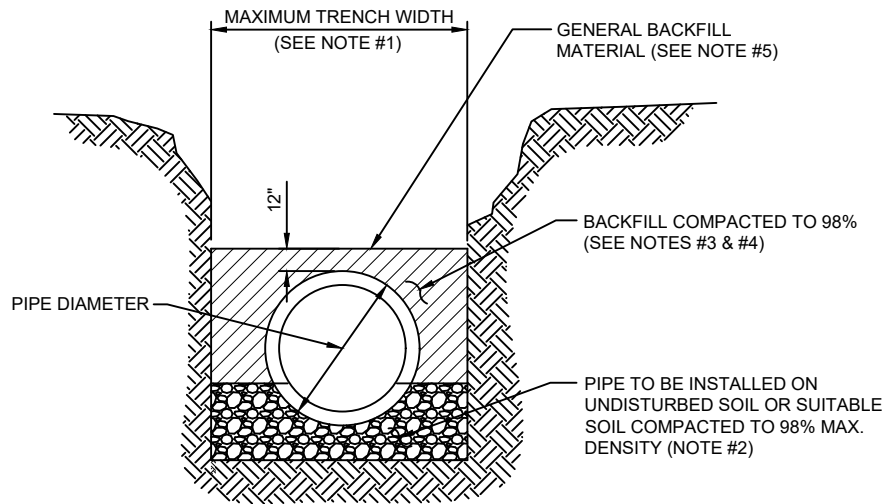

TYPICAL TRENCH

NOTES:

1. TRENCH SIDES SHALL BE APPROXIMATELY VERTICAL BETWEEN AN ELEVATION OF 1 FOOT ABOVE THE TOP OF THE PIPE AND THE CENTER LINE OF THE PIPE; OTHERWISE, TRENCH SIDES SHALL BE AS VERTICAL AS POSSIBLE OR AS REQUIRED BY OSHA STANDARDS. REFER TO THE MEASUREMENT AND PAYMENT SECTION (SECTION #801, PARAGRAPH #4)) TO DETERMINE MAXIMUM PAYLINE WIDTHS.
2. BELL HOLE SHALL BE DUG TO PERMIT THE ENTIRE STRAIGHT BARREL OF THE PIPE TO REST ON THE UNDISTURBED TRENCH BOTTOM. BOULDERS OR LOOSE ROCKS LARGER THAN 3/4 INCH IN SIZE WILL NOT BE PERMITTED IN BACKFILL UP TO 1 FOOT ABOVE THE TOP OF THE PIPE.
3. BACK FILL MATERIAL UP TO A LEVEL OF 1 FOOT OVER THE PIPE SHALL CONSIST OF AASHTO CLASS A-3 SOIL (SUITABLE SOIL) AND SHALL EXCLUDE CLAY MATERIALS AND LOOSE ROCKS LARGER THAN 3/4 INCH SIZE.
4. BACKFILL MATERIAL UP TO A LEVEL 1 FOOT OVER THE TOP OF PIPE OR BOTTOM OF STRUCTURES SHALL BE PLACED IN 6 INCH COMPACTED THICKNESS LAYERS AND SHALL BE COMPACTED TO 98% OF IT'S MAXIMUM DENSITY AS DETERMINED BY THE LABORATORY MODIFIED PROCTOR TEST, ASTM D1557.
5. SEE " EXCAVATION AND EARTHWORK", SECTION 408 FOR ADDITIONAL REQUIREMENTS INCLUDING REMOVAL AND REPLACEMENT OF UNSUITABLE SOILS, DEWATERING, COMPACTION REQUIREMENTS AND DENSITY TESTING OF COMPACTED SOILS.

OPEN CUT TRENCH FOR PRESSURE PIPE IN STATE ROAD RIGHT -OF-WAY

PLATE S-56

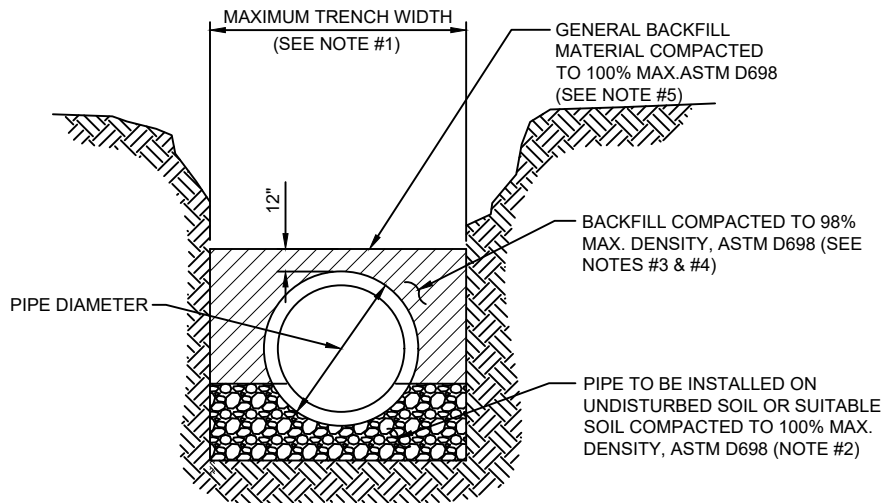

TYPICAL TRENCH

NOTES:

1. TRENCH SIDES SHALL BE APPROXIMATELY VERTICAL BETWEEN AN ELEVATION OF 1 FOOT ABOVE THE TOP OF THE PIPE AND THE CENTER LINE OF THE PIPE; OTHERWISE, TRENCH SIDES SHALL BE AS VERTICAL AS POSSIBLE OR AS REQUIRED BY OSHA STANDARDS. REFER TO THE MEASUREMENT AND PAYMENT SECTION (SECTION #801, PARAGRAPH #4)) TO DETERMINE MAXIMUM PAYLINE WIDTHS.
2. BELL HOLE SHALL BE DUG TO PERMIT THE ENTIRE STRAIGHT BARREL OF THE PIPE TO REST ON THE UNDISTURBED TRENCH BOTTOM. BOULDERS OR LOOSE ROCKS LARGER THAN 3/4 INCH IN SIZE WILL NOT BE PERMITTED IN BACKFILL UP TO 1 FOOT ABOVE THE TOP OF THE PIPE.
3. BACK FILL MATERIAL UP TO A LEVEL OF 1 FOOT OVER THE PIPE SHALL CONSIST OF AASHTO CLASS A-3 SOIL (SUITABLE SOIL) AND SHALL EXCLUDE CLAY MATERIALS AND LOOSE ROCKS LARGER THAN 3/4 INCH SIZE.
4. BACKFILL MATERIAL UP TO A LEVEL 1 FOOT OVER THE TOP OF PIPE OR BOTTOM OF STRUCTURES SHALL BE PLACED IN 6 INCH COMPACTED THICKNESS LAYERS AND SHALL BE COMPACTED TO 100% OF IT'S MAXIMUM DENSITY AS DETERMINED BY THE LABORATORY MODIFIED PROCTOR TEST, ASTM D698.
5. SEE " EXCAVATION AND EARTHWORK", SECTION 408 FOR ADDITIONAL REQUIREMENTS AND EXCEPTIONS INCLUDING REMOVAL AND REPLACEMENT OF UNSUITABLE SOILS, DEWATERING, COMPACTION REQUIREMENTS AND DENSITY TESTING OF COMPACTED SOILS.

HOUSE LATERAL - PLAN VIEW

PLATE S-19

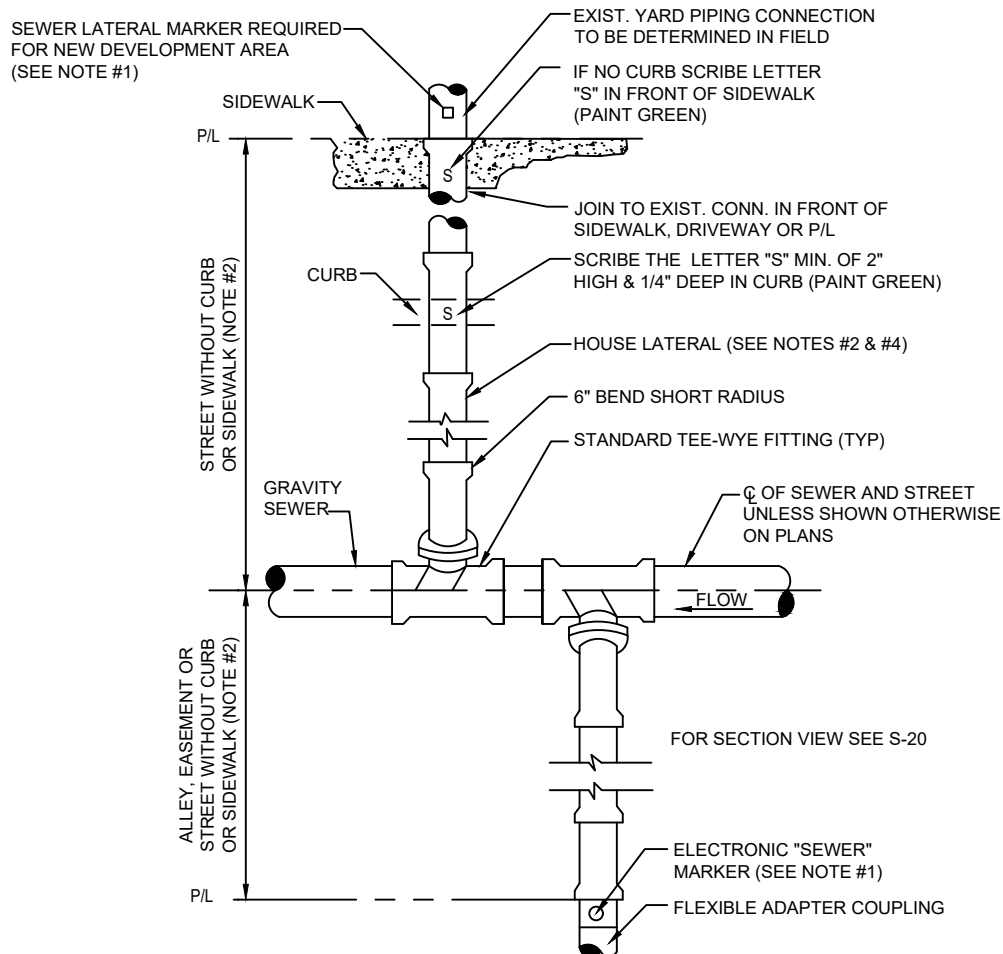

NOTES:

1. TO MARK THE LOCATION OF THE 6" PLUG FOR NEW SERVICE: FOR PROJECTS WHERE NO CONCRETE CURB EXIST, AN ELECTRONIC "SEWER" MARKER IS REQUIRED FOR ALL LATERALS WHICH ARE BEING INSTALL FOR FUTURE USE AT A MAX DEPTH OF 3' AT FINISH GRADE. FOR NEW DEVELOPMENT AREAS WHERE THE SEWER LATERAL IS "NOT IN USE", A LANDSCAPE TIMBER OR 3x3 MIN. P.T. POST (TOP PAINTED GREEN) SHALL BE INSTALLED. WHERE REQUIRED BY JEA OR NO CONCRETE CURB EXIST, AN ELECTRONIC "SEWER" MARKER SHALL BE INSTALLED TO MARKER SHALL ALSO BE INSTALLED..
2. THE MINIMUM SIZE OF ALL HOUSE LATERALS SHALL BE 6 INCHES. THE MAXIMUM LENGTH OF A HOUSE LATERAL SHALL BE 60 FEET (LENGTH BETWEEN SEWER MAIN OR MANHOLE TO CUSTOMERS PROPERTY LINE).
3. NO SEWER SERVICE CONNECTIONS PERMITTED ON GRAVITY SEWER PIPE WHICH ARE 16" AND LARGER.
4. ALL GRAVITY SEWER MAINS AND ASSOCIATED SEWER LATERAL PIPE AND FITTINGS (INCLUDING THE TEE-WYE FITTING) SHALL BE PVC SDR-26.

HOUSE LATERAL - SECTION VIEW

PLATE S-20

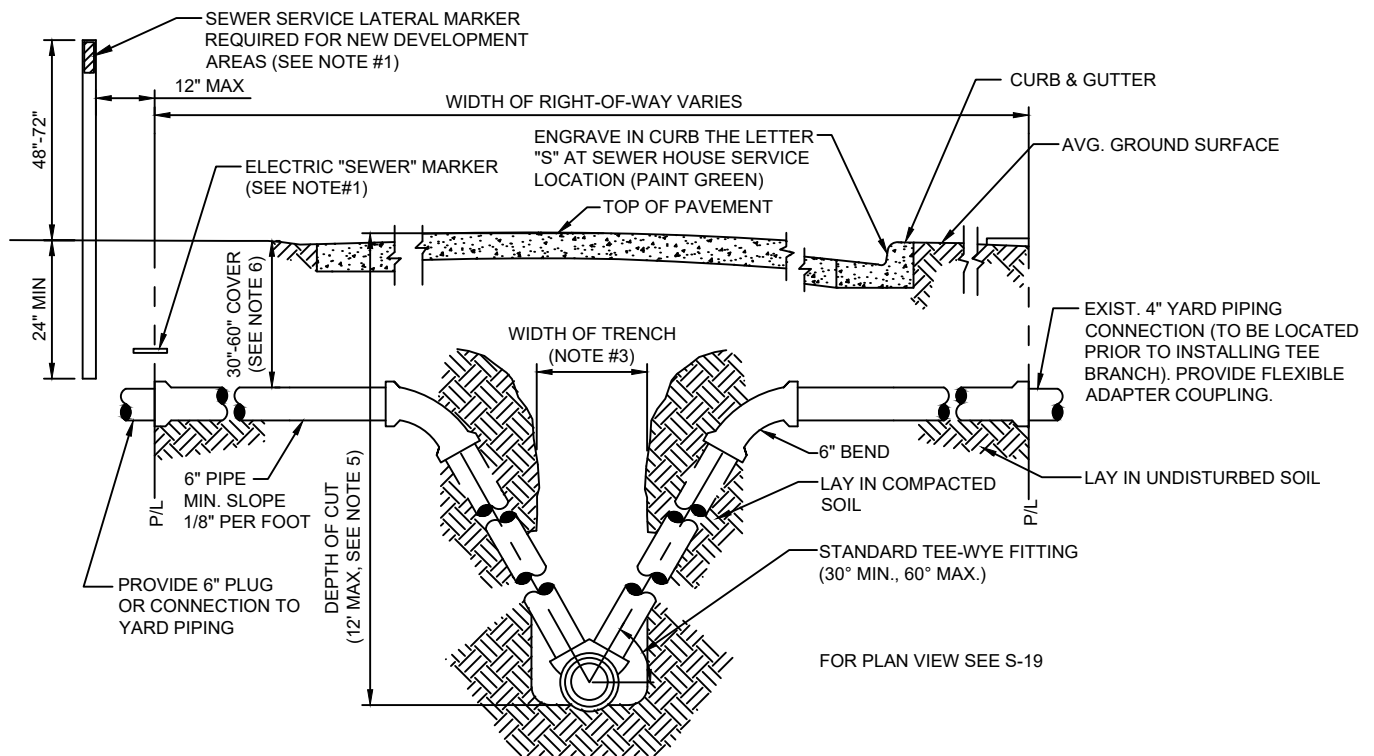

NOTES :

1. TO MARK THE LOCATION OF THE 6" PLUG FOR NEW SERVICE: FOR PROJECTS WHERE NO CONCRETE CURB EXIST, AN ELECTRONIC "SEWER" MARKER IS REQUIRED FOR ALL LATERALS WHICH ARE BEING INSTALL FOR FUTURE USE AT A MAX DEPTH OF 3' AT FINISH GRADE. FOR NEW DEVELOPMENT AREAS WHERE THE SEWER LATERAL IS "NOT IN USE", A LANDSCAPE TIMBER OR 3x3 MIN. P.T. POST (TOP PAINTED GREEN) SHALL BE INSTALLED. WHERE REQUIRED BY JEA OR NO CONCRETE CURB EXIST, AN ELECTRONIC "SEWER" MARKER SHALL BE INSTALLED TO MARKER SHALL ALSO BE INSTALLED.
2. THE MINIMUM SIZE OF ALL HOUSE LATERALS SHALL BE 6 INCHES. THE MAXIMUM LENGTH OF A HOUSE LATERAL SHALL BE 60 FEET (LENGTH BETWEEN SEWER MAIN OR MANHOLE TO CUSTOMERS PROPERTY LINE).
3. SEE MEASUREMENT AND PAYMENT SECTION FOR MAXIMUM PAYMENT WIDTHS.
4. ALL GRAVITY SEWER MAINS AND ASSOCIATED SEWER LATERAL PIPE AND FITTINGS (INCLUDING THE TEE-WYE FITTINGS) SHALL BE PVC SDR-26.
5. UNLESS APPROVED OTHERWISE BY A JEA O&M MANAGER, NO GRAVITY SEWER MAIN WITH SEWER SERVICE LATERALS SHALL BE CONSTRUCTED WITH A "DEPTH OF CUT" GREATER THAN 12 FEET.
6. SEWER SERVICE LATERALS ASSOCIATED WITH GRAVITY SEWER MAINS WHICH ARE DEEPER THAN 12 FEET, MUST BE ROUTED TO A GRAVITY SEWER HIGH-LINE, A MANHOLE OR OTHER JEA APPROVED METHOD.
7. THE SEWER SERVICE LATERAL SHALL BE CONSTRUCTED AT A DEPTH TO ALLOW A GRAVITY CONNECTION BY THE CUSTOMER, WHERE POSSIBLE (CONTINGENT UPON MEETING THE CUSTOMER'S ON-SITE CONDITIONS AND LOCAL CONSTRUCTION STANDARDS), A LATERAL REQUIRING MORE THAN 60" OF COVER MUST BE APPROVED, PRIOR TO CONSTRUCTION, BY JEA.

HOUSE LATERAL OVER CONFLICT PIPE

PLATE S-23

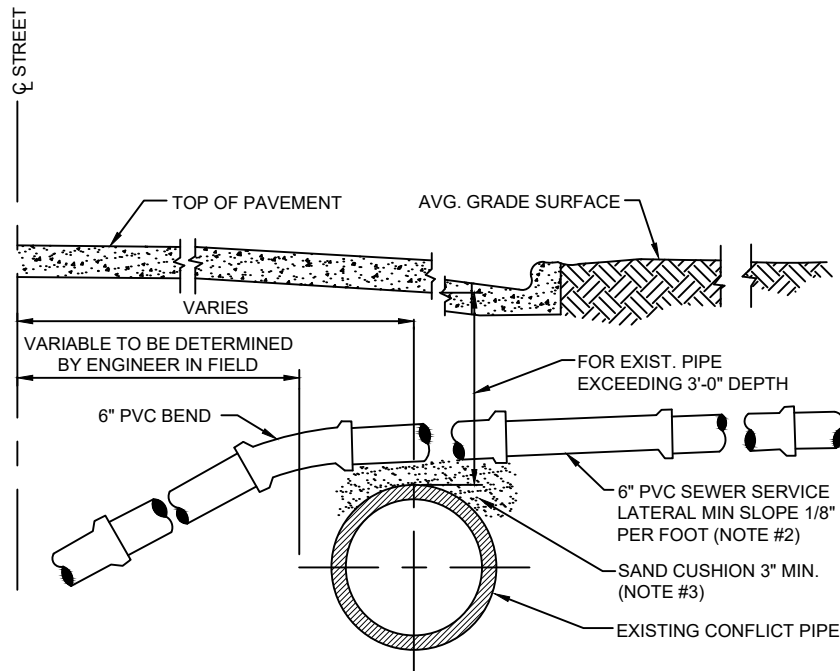

NOTES:

1. ALTERNATE GRADIENT FOR 6 INCH LATERAL SEWERS AT CONFLICTS WITH EXISTING UTILITIES.
2. FLATTER SLOPES MUST BE PRE-APPROVED BY JEA O&M MANAGER (ONLY) PRIOR TO CONSTRUCTION.
3. THE SOILS BETWEEN THE NEW MAIN AND THE CONFLICT PIPE SHALL BE COMPACTED TO 98% OF THE MAXIMUM DENSITY AS DETERMINED BY THE LABORATORY MODIFIED PROCTOR TEST, ASTM D 1557.

HOUSE LATERAL UNDER CONFLICT PIPE

PLATE S-24

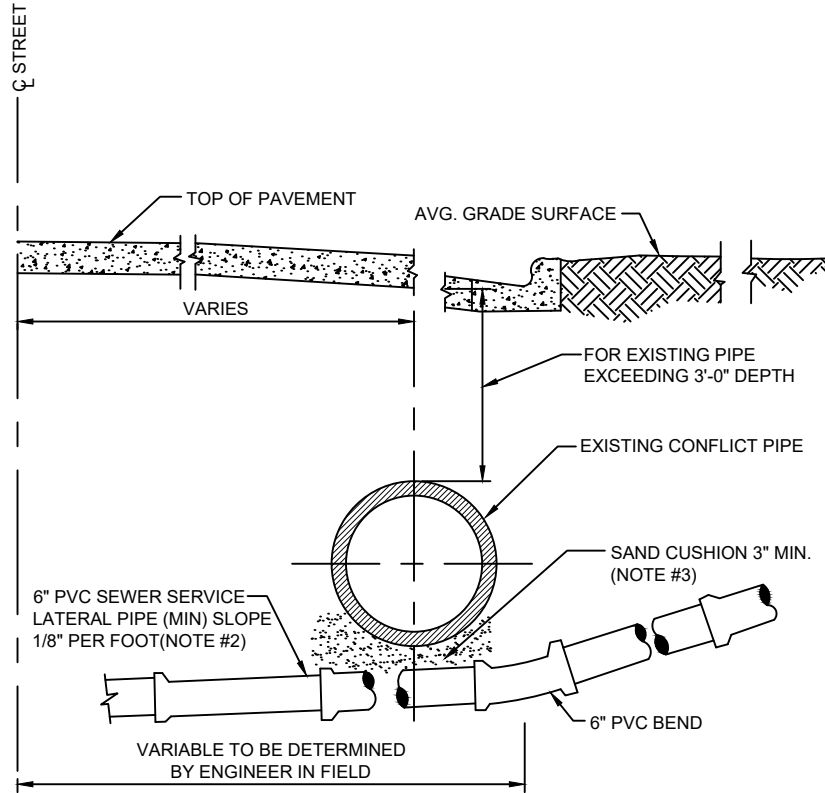

NOTES:

1. ALTERNATE GRADIENT FOR 6 INCH LATERAL SEWERS AT CONFLICTS WITH EXISTING UTILITIES.
2. FLATTER SLOPE MUST BE PRE-APPROVED BY JEA O&M MANAGER (ONLY) PRIOR TO CONSTRUCTION
3. THE SOILS BETWEEN THE NEW MAIN AND THE CONFLICT PIPE SHALL BE COMPACTED TO 98% OF THE MAXIMUM DENSITY AS DETERMINED BY THE LABORATORY MODIFIED PROCTOR TEST, ASTM D 1557.

LOW PRESSURE RESIDENTIAL SEWER FORCE MAIN CONNECTIONS

PLATE S-50

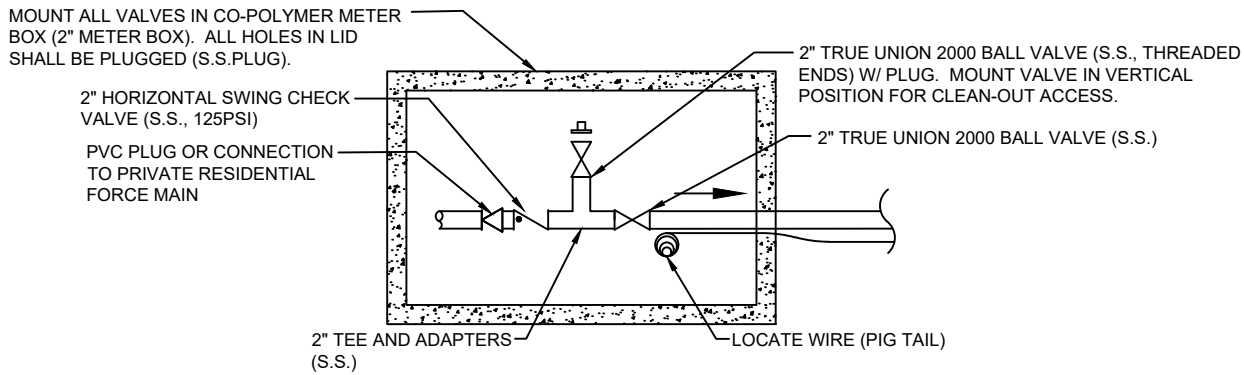

LOW PRESSURE SERVICE CONNECTION POINT

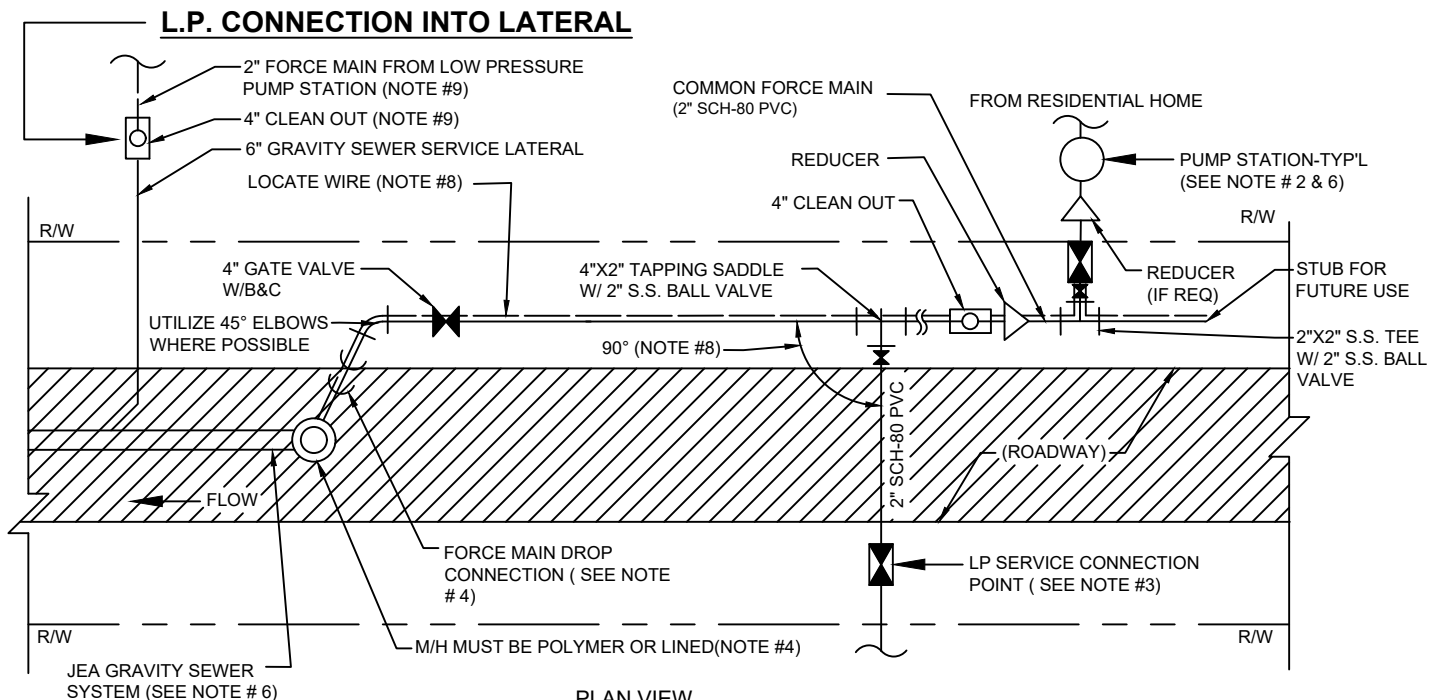

PLAN VIEW

LOW PRESSURE MANIFOLD SYSTEM

NOTES:

1. THIS LOW PRESSURE (LP) SEWER SERVICE ARRANGEMENT IS FOR " SPECIAL CASES ONLY " AND MUST FIRST BE APPROVED BY JEA PRIOR TO DESIGN OR CONSTRUCTION. THIS LOW PRESSURE SEWER MANIFOLD ARRANGEMENT MAY BE UTILIZED TO SERVE UP TO 80 EQUIVALENT RESIDENTIAL UNITS (ERU) AND SHALL BE PERMITTED SIMILAR TO A GRAVITY SEWER MAIN. THIS STANDARD SHALL APPLY TO RESIDENTIAL CUSTOMERS ONLY.
2. RESIDENTIAL PUMP STATION (PS) SHALL BE MAINTAINED BY THE CUSTOMER AND SHALL MEET EPB RULE No.3 (DUVAL COUNTY). THE CUSTOMER IS RESPONSIBLE FOR FINAL PUMP DESIGN AND SELECTION. A CHECK VALVE AND BALL VALVE SHALL BE PROVIDED AT THE PS AND MAINTAINED BY THE CUSTOMER.
3. EACH CUSTOMER SHALL HAVE A SEPARATE "LOW PRESSURE SERVICE CONNECTION POINT" (SEE ABOVE DETAIL). THE CHECK VALVE LOCATED IN THE BOX SHALL DEFINE THE "POINT OF SERVICE". THIS BOX (2" METER BOX WITH PVC PLUG IN TOP) SHALL BE APPROXIMATELY 7 FEET INSIDE THE R/W AND A MINIMUM OF 6 FEET FROM THE WATER METER BOX (IN FRONT OF CUSTOMER HOME).
4. LOW PRESSURE FORCE MAIN DROP CONNECTION AT M/H SHALL INCLUDE A 4" GATE VALVE AND BE IN ACCORDANCE WITH JEA STANDARD PLATE No. S-18. FOR OTHER LOCATION LIMITATIONS SEE DETAIL (W-10 & W-11).
5. ALL PUMP STATIONS, PIPES (W/LOCATE WIRE), VALVES AND FITTINGS WHICH ARE MAINTAINED BY JEA SHALL BE OF JEA APPROVED MATERIALS AND SHALL BE CONSTRUCTED IN ACCORDANCE WITH JEA W&S STANDARD
6. PER DEP RULES AND EPB RULE No.3, A LOW PRESSURE PUMP STATION CONNECTION INTO A JEA FORCE MAIN IS NOT ALLOWED. (NO EXCEPTIONS).
7. AS BUILTS FOR ALL UTILITIES WITHIN THE R/W SHALL BE PROVIDED TO JEA IN ACCORDANCE WITH JEA STANDARDS.
8. LOCATE WIRE IS REQUIRED ALONG THE MAIN PIPING AND SERVICE LATERALS TO THE LAST CUSTOMER CONNECTION BOX. (AS SHOWN IN DETAIL)
9. FOR RESIDENTIAL CUSTOMERS LOCATED IN AREAS OF LOW ELEVATION, THE CUSTOMER MAY BE REQUIRED TO OPERATE AND MAINTAIN A LOW PRESSURE PUMP STATION (SEE NOTE #2) WHICH MAY DISCHARGE INTO A 6 INCH GRAVITY SEWER SERVICE LATERAL. IN THESE CASES, THE CUSTOMER SHALL PROVIDE AND MAINTAIN A 4 INCH CLEAN-OUT LOCATED AT THE CONNECTION POINT (AT R/W LINE).

GANG SEWER SERVICES FOR CONDOS AND TOWNHOMES

PLATE S-51

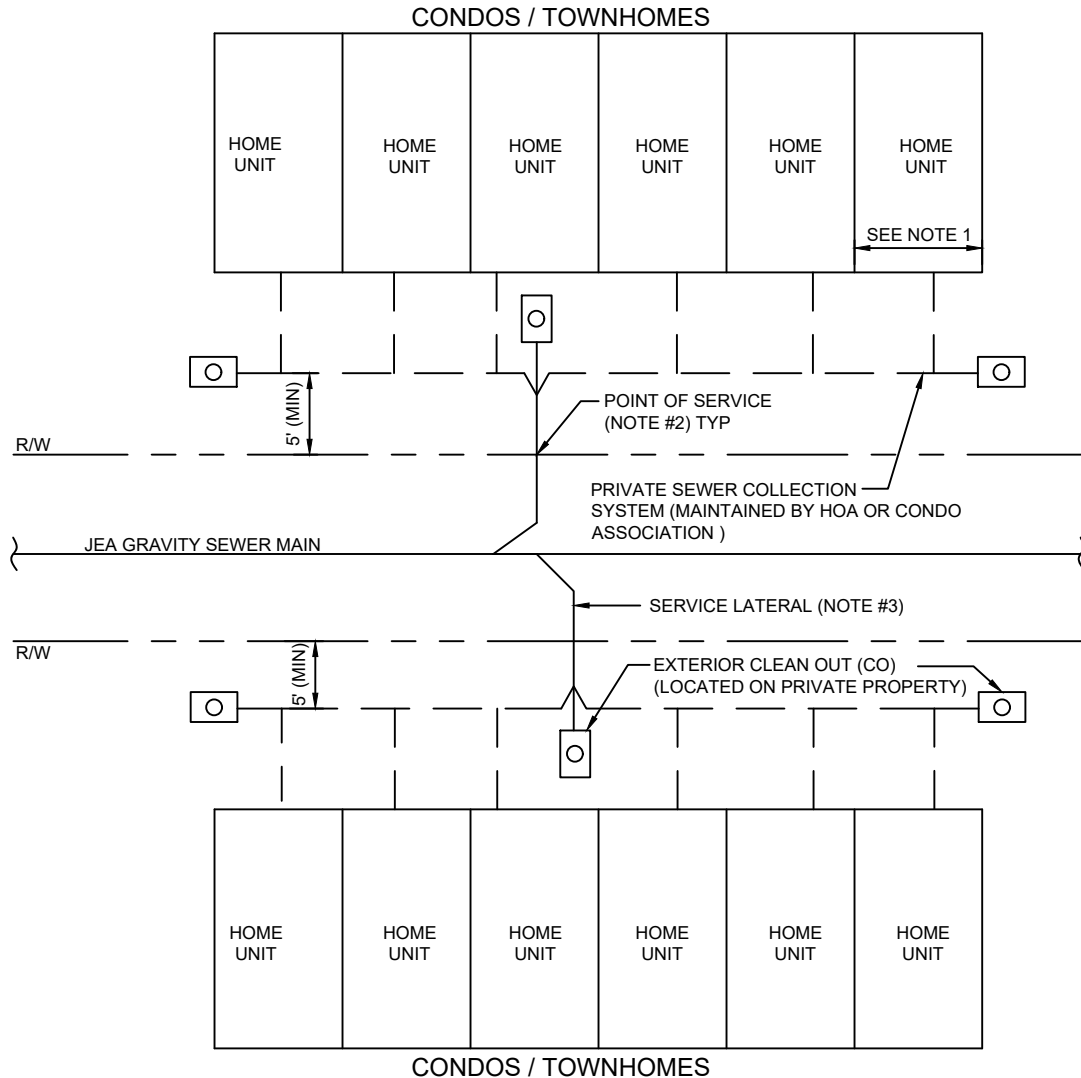

GANG SEWER SERVICES

NOTES:

1. THIS STANDARD MAY APPLY TO CONDOS AND/OR TOWNHOMES WITH PRIVATE LOT LINES LESS THAN 40 FEET WIDE.
2. THE " POINT OF SERVICE " (POS) SHALL BE DEFINED AT THE R/W LINE FOR ALL LATERALS. JEA WILL ONLY BE RESPONSIBLE FOR O&M (EXCLUDING STOPPAGES) BEGINNING AT THE P.O.S. TO THE MAIN (60 FEET MAX). THEREFORE, O&M RESPONSIBILITY BETWEEN THE P.O.S. AND THE CUSTOMER IS BY OTHER (HOME OWNER ASSOCIATION OR OTHER). CUSTOMER WILL CONTINUE TO BE RESPONSIBLE FOR FREE FLOW OF SEWAGE BETWEEN CUSTOMER TO MAIN.
3. SERVICE LATERALS BETWEEN MAIN AND R/W SHALL BE 6" SDR-26 (PVC) AT 1/4" SLOPE, AT A MINIMUM, AND SERVE A MAXIMUM OF 6 HOME UNITS. ENGRAVE AN "S" IN CURB TO SHOW LOCATION OF LATERAL. MANHOLE SHALL BE REQUIRED AT THE MAIN IF THE LATERAL IS LARGER THAN 6 INCH SIZE. LARGER LATERALS SHALL BE SIZED BY DESIGN ENGINEER. ALL PIPING ON PRIVATE PROPERTY SHALL MEET LOCAL PLUMBING CODE REQUIREMENTS AND BE MAINTAINED BY OWNER. ALL CLEANOUTS LOCATED IN PAVED AREAS SHALL BE CAST IRON FRAME AND TOP.

SEWER LATERAL VACUUM SYSTEM

PLATE S-52

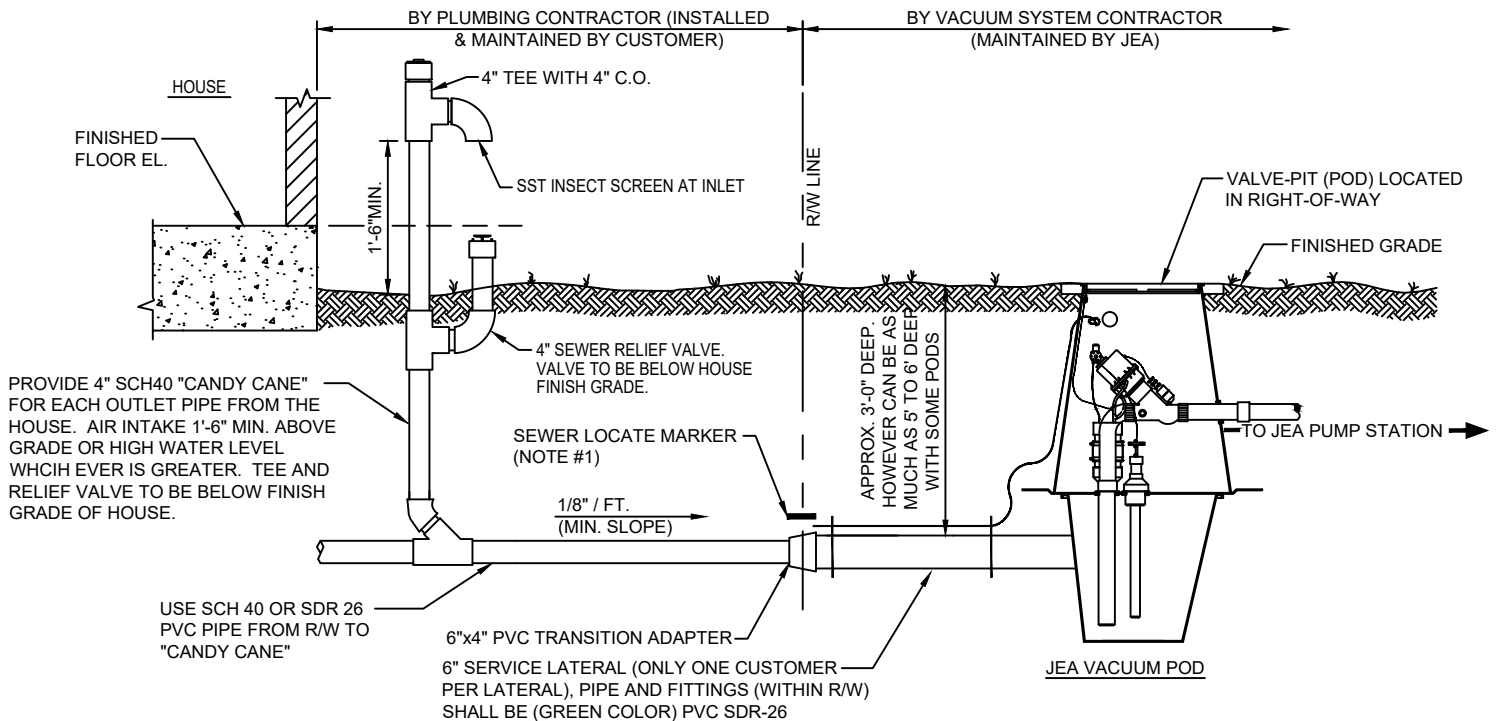

NOTES:

1. AN "S" SHALL BE SCRIBED IN THE CURB (PAINTED GREEN) TO INDICATE LOCATION OF LATERAL AT THE R/W. FOR SEPTIC TANK PHASE-OUT PROJECTS AN ELECTRONIC "SEWER" MARKER IS REQUIRED FOR ALL LATERALS WHICH ARE "NOT" IN USE. FOR NEW DEVELOPMENT AREAS WHERE THE SEWER LATERAL IS "NOT IN USE", A LANDSCAPE TIMBER OR 3x3 MIN. P.T. POST (TOP PAINTED GREEN) SHALL BE INSTALLED TO MARK THE LOCATION OF THE 6" PLUG.
2. THE MINIMUM SIZE OF ALL HOUSE LATERALS SHALL BE 6 INCHES AND SHALL BE 6 FEET LONG, AT A MINIMUM. THE MAXIMUM LENGTH OF A HOUSE LATERAL SHALL BE 60 FEET (LENGTH BETWEEN VALVE PIT OR MANHOLE TO CUSTOMERS PROPERTY LINE).
3. LOCATE WIRE SHALL BE INSTALLED ALONG THE 6" GRAVITY SEWER LATERALS BEGINNING INSIDE THE POD (PROVIDE A 2" DIA. x 1/8" THICK BRASS TAG INDICATING THE HOME SERVICE ADDRESS OR APPROVED PROPERTY I.D. (EMBOSSED) AND ATTACH TO THE END OF THE WIRE) TO THE R/W. WIRE END SHALL BE TAPED WATER TIGHT AND SECURED TO THE PIPE, BELOW GROUND. THE END OF THE LOCATE WIRE AT THE R/W DOES NOT HAVE TO BE EXPOSED. LOCATE WIRE SHALL BE 10 GAGE, SINGLE STRAND, UF RATED (DIRECT BURIAL), COPPER WIRE WITH 30 MIL (MIN.) INSULATION WITH EITHER WHITE OR YELLOW COLOR. THE CONTRACTOR SHALL PROVIDE FIELD LOCATE WIRE TESTING AS PART OF THE FINAL PROJECT INSPECTION.
4. REMOVE THE VALVE OUT OF PODS WHICH SERVE NOT IN USE PODS (NO ACTIVE LATERALS) AFTER DRY FIT HAS BEEN CONFIRMED AND PROVIDE 3" PVC SPOOL PIECE AS SHOWN ABOVE. FOR THESE CASES, DELIVER THE NEW UNUSED VALVE TO JEA OEM DEPARTMENT FOR FUTURE INSTALLATION.
5. VACUUM SEWER MAINS (PIPE AND FITTINGS) SHALL BE GREEN PVC DR-25 MEETING ASTM D-3139. THE USE OF WYE FITTINGS (PVC OR D.I.P. WITH EPOXY COATINGS) SHALL BE UTILIZED (NO TEE FITTING).
6. VACUUM SEWER (POD) SHALL NOT BE PLACED IN DRIVEWAY, REFERENCE RULES AND REGULATIONS FOR WATER, SEWER AND RECLAIM SERVICES.

SANITARY FORCE MAIN CONNECTION FOR 16" AND LARGER PIPING FOR PRIVATE PUMPING STATIONS PLATE S-22

COMMON SANITARY STUB-OUT ALONG
CONTINUOUS RIGHT-OF-WAY

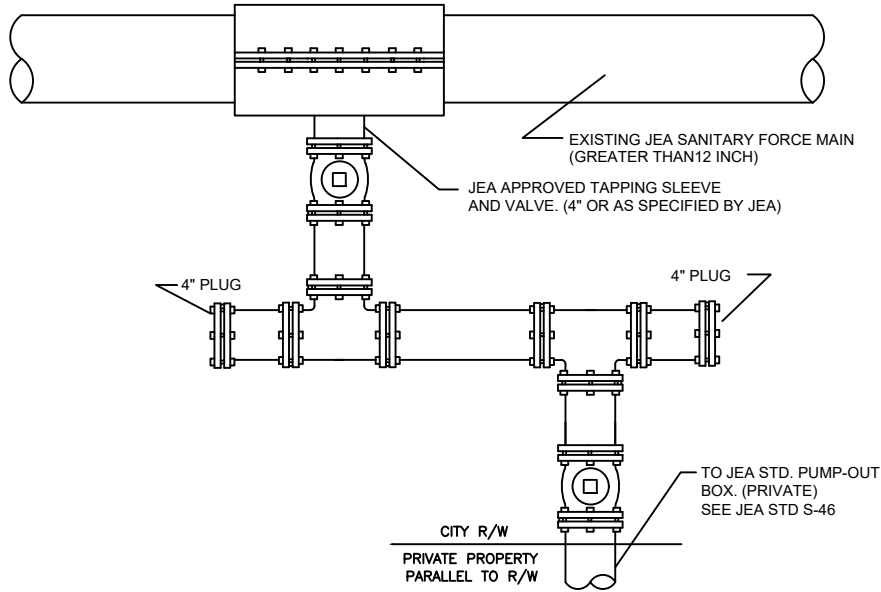

FORCE MAIN
SERVICE STUB FOR
16" AND LARGER PIPING

FORCE MAIN SIZE	DISTANCE BETWEEN TAPS
16"	300LF
20"	500LF
24"	1000LF
30"	1000LF

PRIVATE PUMP OUT ASSEMBLY

PLATE S-46

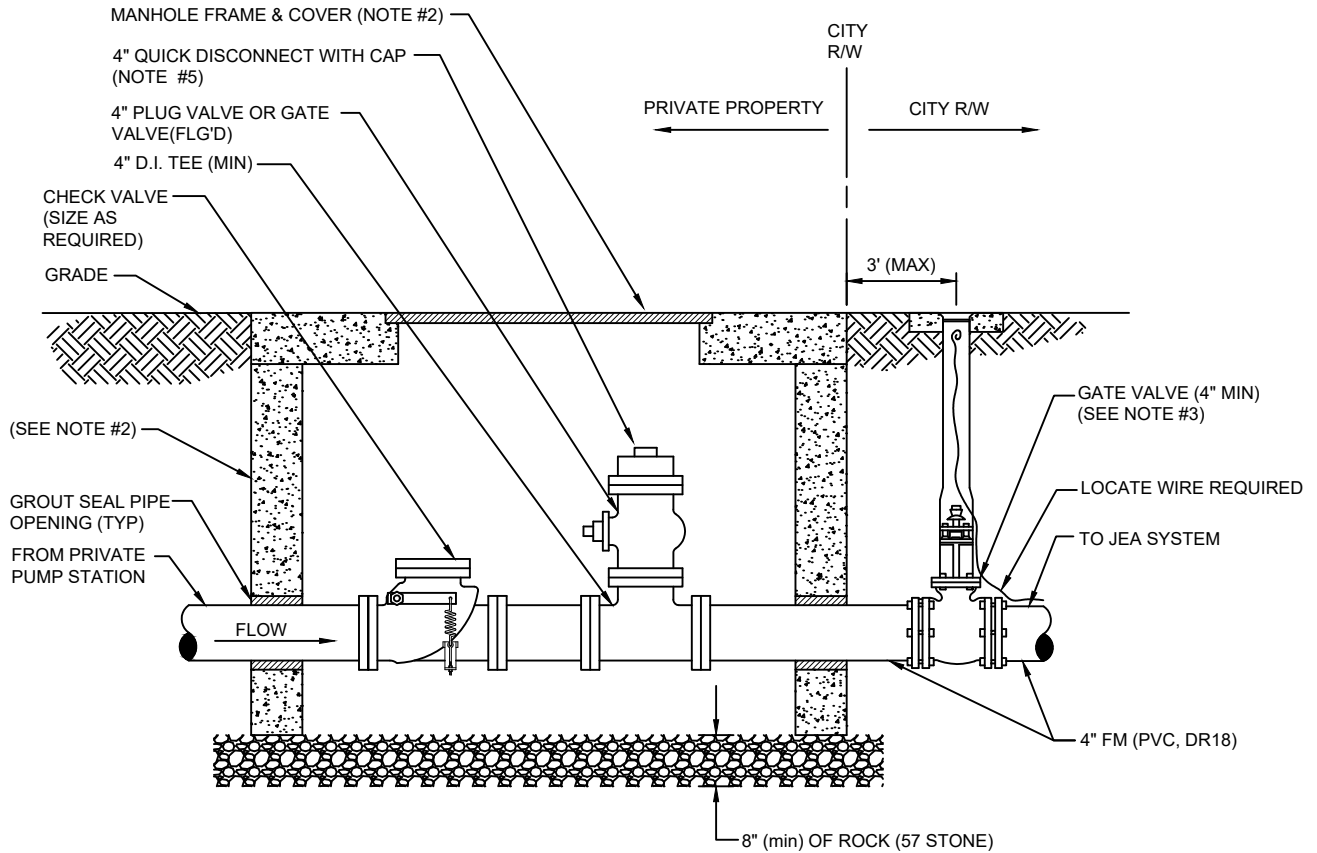

NOTES :

1. SEWER PUMP-OUT BOX SHALL BE CONSTRUCTED ON PRIVATE PROPERTY AND LOCATED AT THE R/W LINE. THE PREFERRED CONSTRUCTION LAYOUT IS SHOWN ABOVE.
2. ASSEMBLY TO BE ENCLOSED WITHIN A 48"x48" (MIN) PRECAST CONCRETE BOX WITH OPEN BOTTOM W/H-20 TRAFFIC LOADING COVER OR TYPE "C" MANHOLE OPEN BOTTOM WITH FRAME AND COVER (NON-JEA LOGO TYPE COVER).
3. A JEA APPROVED GATE VALVE (4" MIN) SHALL BE PROVIDED AT THE R/W LINE FOR ALL FORCE MAIN PIPING WHICH EXCEEDS 15' LINEAR FEET WITHIN THE CITY R/W AREA. THE GATE VALVE AT THE R/W LINE IS NOT REQUIRED WHERE THE CONNECTION (CONNECTION AT JEA MAIN) IS LOCATED ON THE SAME SIDE OF THE STREET AS THE PUMP-OUT BOX (SHORT-SIDE SERVICE) AND CONSIST OF 15 LINEAR FEET OR LESS WITHIN THE CITY R/W AREA.
4. NO CONNECTIONS PERMITTED INTO JEA FORCE MAINS WHICH ARE GREATER THAN 12" WITHOUT PRIOR JEA APPROVAL.
5. QUICK DISCONNECT WITH CAP SHALL BE ALUMINUM AND BE POSITIONED DIRECTLY UNDER MANHOLE LID FOR ACCESS.

FUSIBLE PVC PIPE ALLOWABLE BEND RADIUS AND PULLING FORCE

PLATE S-21

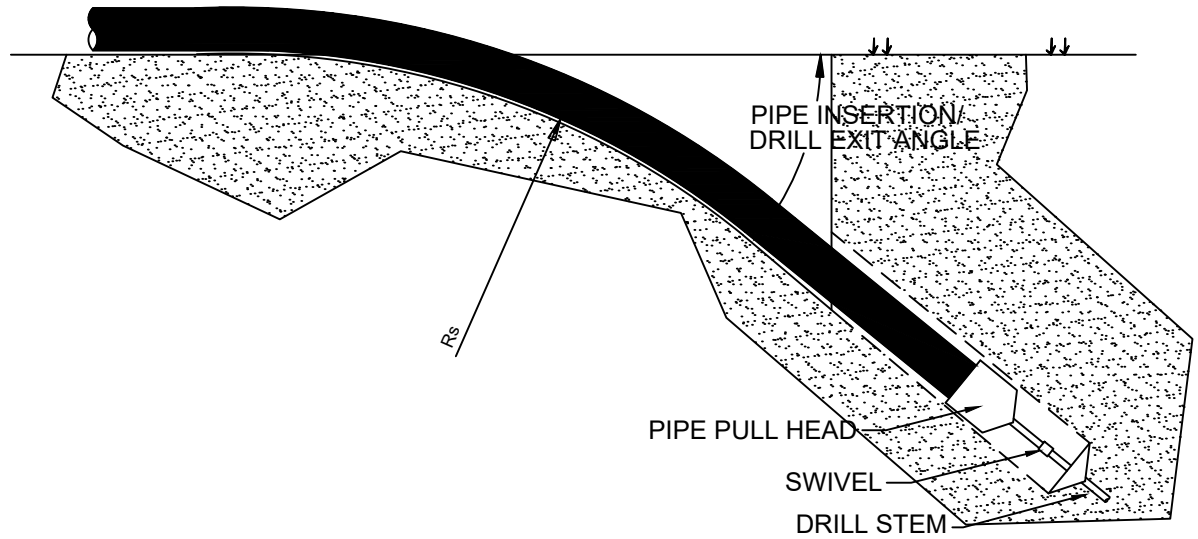

PIPE SIZE	MINIMUM ALLOWABLE BENDING RADIUS - R_s (FT)	MAXIMUM ALLOWABLE PULLING FORCE (DR18) (K-LBS)
4"	100	10
6"	144	21
8"	189	37
10"	231	56
12"	275	80

- PIPE SIZES GREATER THAN 12" SHALL BE HIGH DENSITY POLYETHYLENE (HDPE), CALCULATIONS SUPPLIED BY THE DESIGNED ENGINEER

DUAL DIRECTIONAL DRILLING

PLATE S-21A

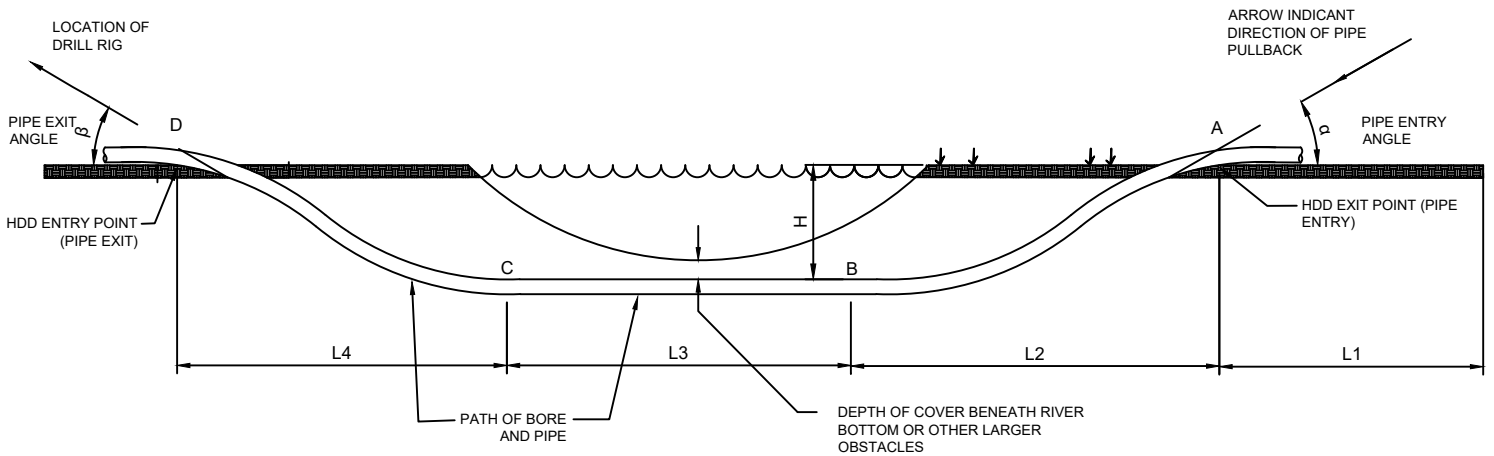
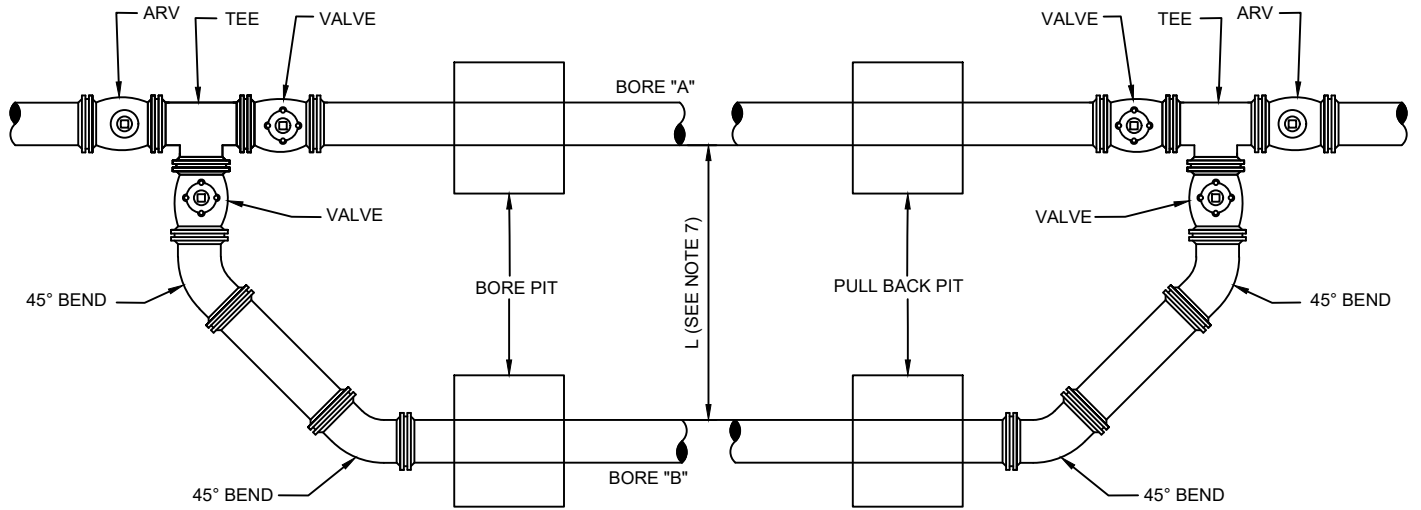

NOTES:

1. POINTS A, B, C, & D PULL FORCE ON PIPE.
2. L1-ADDITIONAL LENGTH OF PIPE REQUIRED FOR HANDLING AND THERMAL CONTRACTION
3. L2-HORIZONTAL DISTANCE TO ACHIEVE DESIRED DEPTH
4. L3-ADDITIONAL DISTANCE TO TRAVERSE AT DESIRED DEPTH
5. L-4 HORIZONTAL DISTANCE TO RISE TO SURFACE
6. H-DEPTH OFF BORE HOLE FROM GROUND SURFACE
7. HORIZONTAL AND VERTICAL DISTANCE BETWEEN BORE "A" TO BORE "B"

PVC PIPE RESTRAINT JOINT SCHEDULE

PLATE S-38A

LENGTH (L) TO BE RESTRAINED

(SEE PLATE Nos. 38C & 38D FOR ADDITIONAL DETAILS)

NOMINAL PIPE SIZE (IN.)	HORIZONTAL BENDS				VERTICAL OFFSETS 45° BENDS (SEE NOTE 4)		VALVES OR DEAD ENDS L (FT.)
	90° BENDS L (FT.)	45° BENDS L (FT.)	22.5° BENDS L (FT.)	11.25° BENDS L (FT.)	UPPER	LOWER	
					L (FT.)	L (FT.)	
4	21	9	5	3	17	3	47
6	30	13	6	3	23	4	66
8	38	16	8	4	30	6	86
10	45	19	9	5	36	7	103
12	53	22	11	6	43	8	121
14	61	26	13	6	50	9	140
16	66	28	14	7	55	10	154
18	73	30	15	8	60	11	170
20	79	33	16	8	66	12	186
24	79	33	16	8	77	15	185
30	93	39	19	10	97	17	222
36	106	39	21	11	107	20	257
42	117	49	24	12	120	24	289
48	144	53	26	13	133	26	321

REDUCERS	
SIZE (IN.)	L (FT.)
6x4	34
8x6	36
8x4	62
10x8	35
10x6	63
12x10	36
12x8	64
16x12	66
16x10	92
20x18	35
20x16	66
20x12	117
24x20	56
24x18	80
24x16	101
30x24	78
30x20	121
36x30	78
36x24	141
42x36	75
42x30	140
48x42	75
48x36	139

TEES SEE NOTE 5		
RUN SIZE (IN.)	BRANCH SIZE (IN.)	L (FT.)
4	4	F.O.
4	6	10
	4 < LESS	F.O.
8	8	29
	6 < LESS	F.O.
10	10	45
	8	13
	6 < LESS	F.O.
12	12	62
	10	32
	8 < LESS	F.O.
16	16	94
	12	39
	10	5
	10 < LESS	F.O.
20	20	125
	16	76
	12	14
	10 < LESS	F.O.
24	24	124
	20	84
	16	36
	12 < LESS	F.O.
30	30	159
	24	104
	20	60
	16	5
	16 < LESS	F.O.
36	36	192
	30	142
	24	83
	20	33
	16 < LESS	F.O.
42	42	223
	36	178
	30	124
	24	59
	20	5
	16 < LESS	F.O.
48	48	253
	42	209
	36	162
	30	104
	24	34
	20 < LESS	F.O.

F.O. = FITTING ONLY

PVC PIPE RESTRAINT NOTES:

- THIS SCHEDULE SHALL BE UTILIZED ON ALL WATER, SEWER FORCE MAIN OR RECLAIMED WATER SYSTEMS. ALL FITTINGS SHALL BE RESTRAINED TO LENGTHS INDICATED ON THE ABOVE SCHEDULE, AT A MINIMUM.
- ASSUMPTIONS: PVC PIPE, SAFETY FACTOR=1.5, TEST PRESSURE=150PSI, SOIL=GM OR SM, TRENCH TYPE 3, DEPTH OF COVER=30 INCHES FOR 20" AND SMALLER PIPE SIZE OR 36 INCHES FOR 24" AND LARGER PIPE SIZE.
- BENDS AND VALVES: SHALL BE RESTRAINED ON EACH SIDE OF FITTING.
- VERTICAL OFFSETS: ARE APPROX. 3 FEET COVER ON TOP AND APPROX. 8 FEET COVER ON BOTTOM. PER THE DETAILS, Lu IS THE RESTRAINED LENGTH FOR THE UPPER (TOP) LEVEL. Li IS THE RESTRAINED LENGTH FOR THE LOWER (DEEPER) LEVEL. ASSUME 45 DEGREE BENDS.
- TEES: TOTAL LENGTH BETWEEN FIRST JOINTS OR RESTRAINED LENGTH ON EITHER SIDE OF TEE (RUN) SHALL BE A TOTAL DISTANCE OF 30 FEET (MIN). SEE SCHEDULE ABOVE FOR RESTRAINT LENGTH ON TEE "BRANCH" LINE.
- HDPE TO PVC TRANSITIONS: THE PVC PIPE SIDE SHALL BE RESTRAINED 35 FT (MIN).
- THE INSTALLATION OF BELL HARNESS RESTRAINTS AT PVC JOINTS (DR-18 & 25 PIPE) SHALL BE COMPLETED PER THE MANUFACTURERS RECOMMENDATION, WHICH INCLUDES NOT OVER TIGHTENING THE PARALLEL RODS/NUTS. THESE NUTS SHOULD ONLY BE SNUG TIGHT. THE HOME MARKS ON THE PIPE SHOULD ALWAYS BE VISIBLE AFTER THE RESTRAINT IS INSTALLED. OVERHOMING THE JOINT MAY CAUSE A FAILURE AT THE BELL RESULTING IN A SERVICE OUTAGE.

MECHANICAL RESTRAINT DETAILS - I

PLATE S-38C

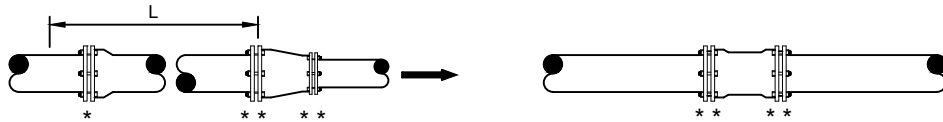
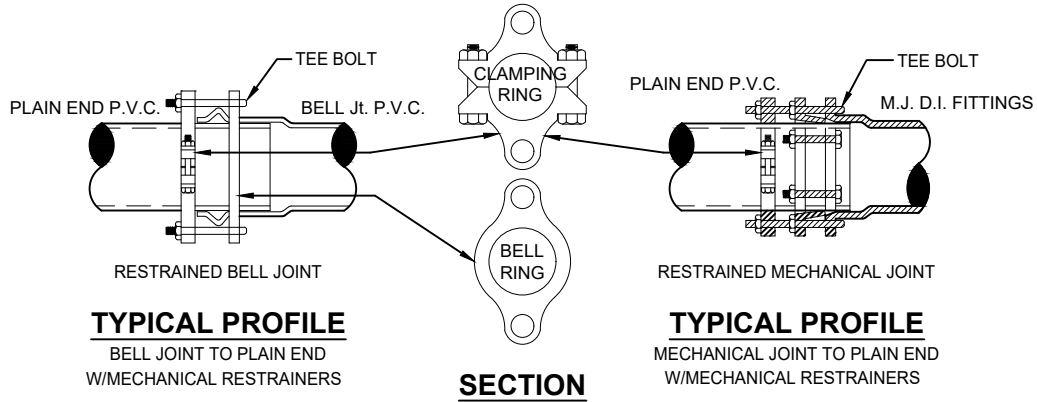

REDUCER

MECHANICAL JOINT SLEEVES

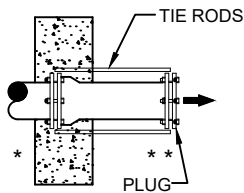

NO. OF TIE RODS REQUIRED

3" - 8"	DIAMETER MAIN - 2 TIE RODS REQUIRED PER JOINT (3/4" ROD)
10" - 12"	DIAMETER MAIN - 4 TIE RODS REQUIRED PER JOINT (3/4" ROD)
14" - 16"	DIAMETER MAIN - 6 TIE RODS REQUIRED PER JOINT (3/4" ROD)
18" - 20"	DIAMETER MAIN - 8 TIE RODS REQUIRED PER JOINT (3/4" ROD)
24"	DIAMETER MAIN - 12 TIE RODS REQUIRED PER JOINT (3/4" ROD)
30" - 36"	DIAMETER MAIN - 14 TIE RODS REQUIRED PER JOINT (1" ROD)
42" - 48"	DIAMETER MAIN - 16 TIE RODS REQUIRED PER JOINT (1 1/4" ROD)
54"	DIAMETER MAIN - 18 TIE RODS REQUIRED PER JOINT (1 1/4" ROD)

DEAD - END THRUST COLLAR ANCHOR

TO BE USED INSTEAD OF TOTAL RESTRAINED LENGTH (OPTIONAL) SIZE AS PER THRUST BLOCK DETAIL (W-38). SEE DETAILS W-36 & W-37.

GENERAL NOTE:

1. PAY ITEM " * " DENOTES A RESTRAINT WHICH IS PAID FOR ON A PER EACH BASIS.
2. PAY ITEM " ** " DENOTES A RESTRAINT WHICH IS INCLUDED IN THE UNIT PRICE BID FOR FITTING OR VALVE.
3. INDICATES DIRECTION OF THRUST FORCE.
4. THE USE OF THRUST BLOCKS IS PROHIBITED UNLESS SPECIFICALLY APPROVED BY JEA.

MECHANICAL RESTRAINT DETAILS - II

PLATE S-38D

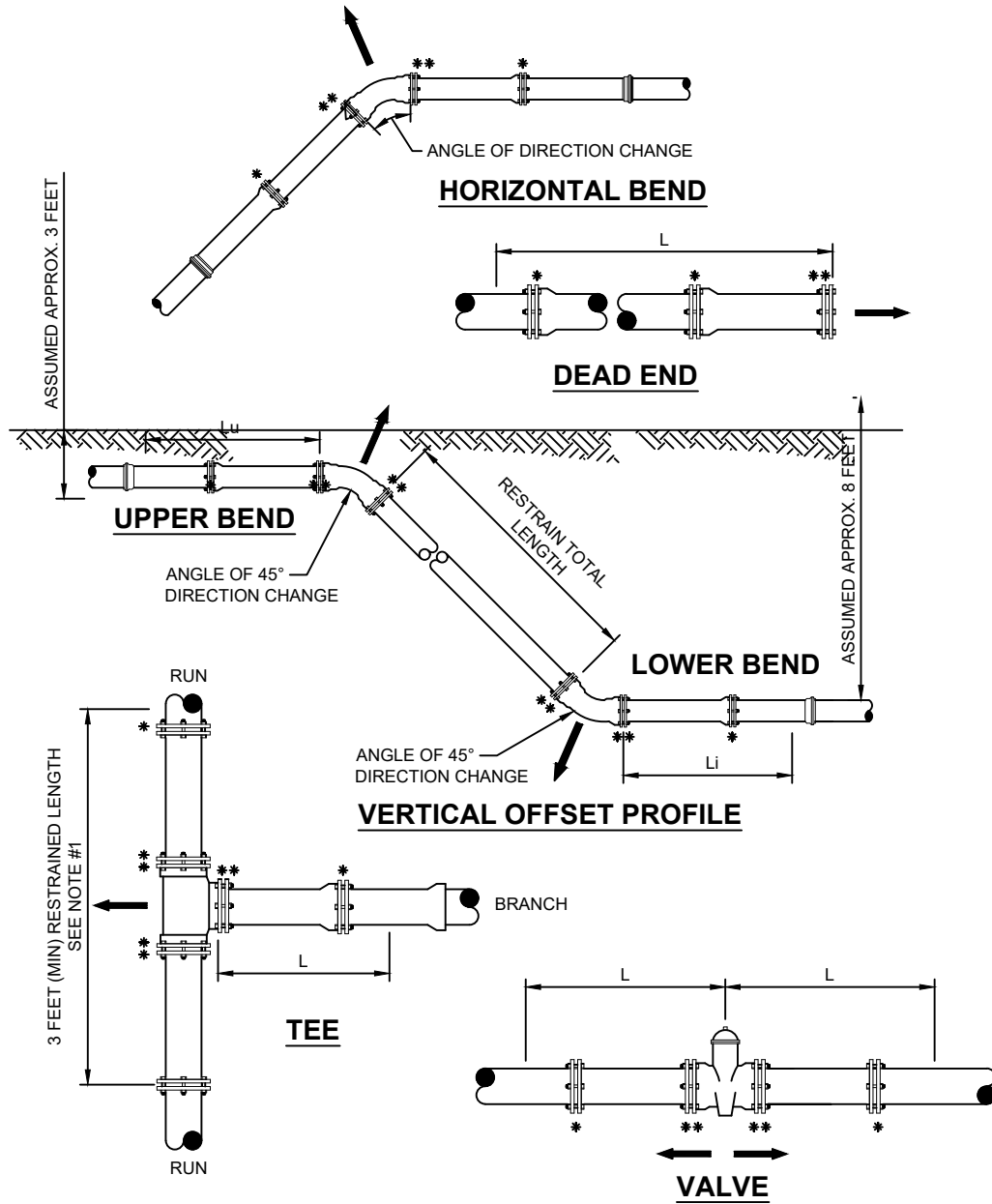

NOTES:

1. TOTAL LENGTH BETWEEN FIRST JOINTS OR RESTRAINED LENGTH ON EITHER SIDE OF TEE (RUN) SHALL BE A TOTAL DISTANCE OF 6 FEET (MIN.). THE PROJECT ENGINEER CAN INCREASE THIS LENGTH TO REDUCE THE NUMBER OF RESTRAINS REQUIRED. ANY CHANGES TO THIS TABLE MUST BE SUBMITTED TO JEA FOR APPROVAL.
2. PAY ITEM **** DENOTES A RESTRAINT WHICH IS PAID FOR ON A PER EACH BASIC.
3. PAY ITEM ***** DENOTES A RESTRAINT WHICH IS INCLUDED IN THE UNIT PRICE BID FOR FITTING OR VALVE.

PLUGGED DEAD END USING TIE RODS

PLATE S-43

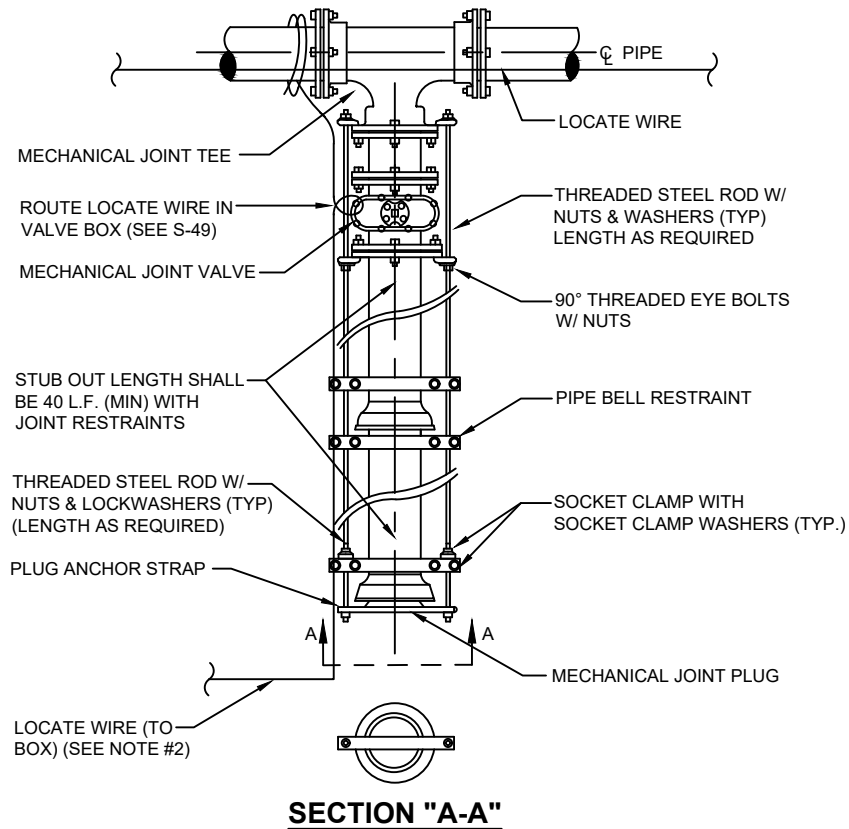

NOTES:

1. IN LIEU OF BELL/ROD RESTRAINTS, MECHANICAL JOINT RESTRAINTS MAY BE USED.
2. LOCATING WIRE REQUIRED, UTILIZING A LOCATE WIRE BOX INSTALLED AT PLUG LOCATION.
3. NUMBER OF TIE RODS REQUIRED IS AS FOLLOWS:

3" - 8"	DIAMETER MAIN - 2 TIE RODS REQUIRED PER JOINT (3/4" ROD)
10" - 12"	DIAMETER MAIN - 4 TIE RODS REQUIRED PER JOINT (3/4" ROD)
14" - 16"	DIAMETER MAIN - 6 TIE RODS REQUIRED PER JOINT (3/4" ROD)
18" - 20"	DIAMETER MAIN - 8 TIE RODS REQUIRED PER JOINT (3/4" ROD)
24"	DIAMETER MAIN - 12 TIE RODS REQUIRED PER JOINT (3/4" ROD)
30" - 36"	DIAMETER MAIN - 14 TIE RODS REQUIRED PER JOINT (1" ROD)
42" - 48"	DIAMETER MAIN - 16 TIE RODS REQUIRED PER JOINT (1 1/4" ROD)
54"	DIAMETER MAIN - 18 TIE RODS REQUIRED PER JOINT (1 1/4" ROD)
4. THE LOCATION OF THE DEAD END PLUG SHALL NOT BE UNDER PAVEMENT, IF POSSIBLE. THE STUB OUT SHALL EXTEND BEYOND THE INTERSECTION AREAS OR ROAD CROSSING BY 10 FEET (MIN.) WHERE POSSIBLE.

PLUGGED DEAD END USING MECHANICAL RESTRAINTS

PLATE S-44

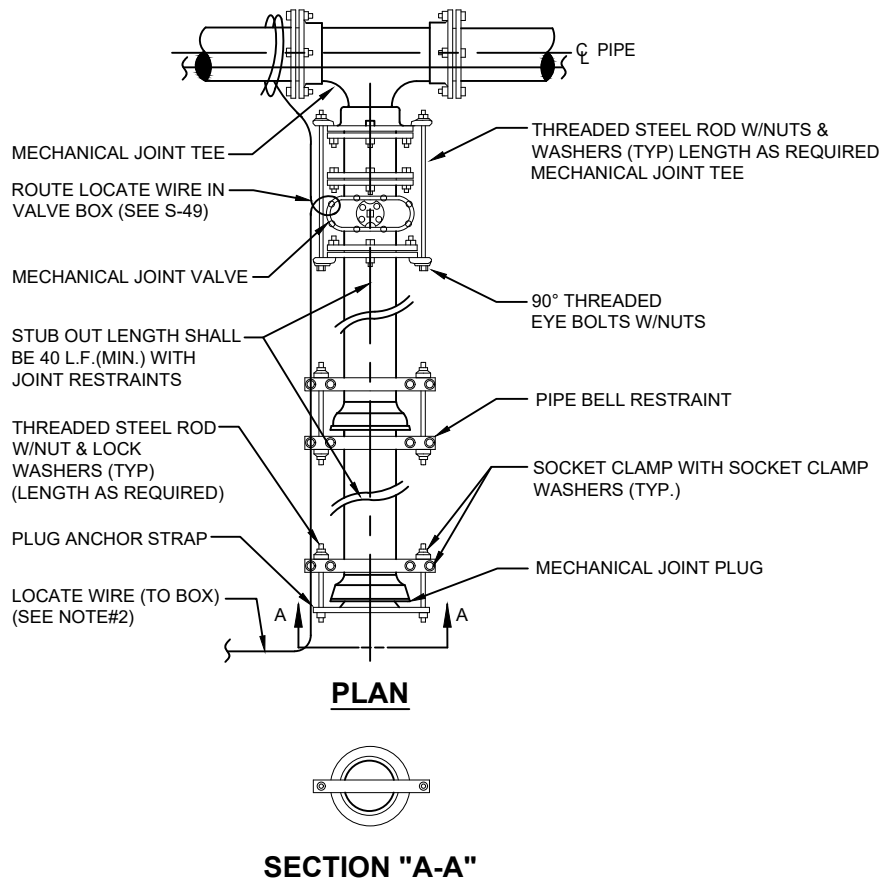

NOTES:

1. IN LIEU OF BELL/ROD RESTRAINTS, MECHANICAL JOINT RESTRAINTS MAY BE USED.
2. LOCATING WIRE REQUIRED, UTILIZING A LOCATE WIRE BOX INSTALLED AT PLUG LOCATION.
3. NUMBER OF TIE RODS REQUIRED IS AS FOLLOWS:

3" - 8"	DIAMETER MAIN - 2 TIE RODS REQUIRED PER JOINT (3/4" ROD)
10" - 12"	DIAMETER MAIN - 4 TIE RODS REQUIRED PER JOINT (3/4" ROD)
14" - 16"	DIAMETER MAIN - 6 TIE RODS REQUIRED PER JOINT (3/4" ROD)
18" - 20"	DIAMETER MAIN - 8 TIE RODS REQUIRED PER JOINT (3/4" ROD)
24"	DIAMETER MAIN - 12 TIE RODS REQUIRED PER JOINT (3/4" ROD)
30" - 36"	DIAMETER MAIN - 14 TIE RODS REQUIRED PER JOINT (1" ROD)
42" - 48"	DIAMETER MAIN - 16 TIE RODS REQUIRED PER JOINT (1 1/4" ROD)
54"	DIAMETER MAIN - 18 TIE RODS REQUIRED PER JOINT (1 1/4" ROD)
4. THE LOCATION OF THE DEAD END PLUG SHALL NOT BE UNDER PAVEMENT, IF POSSIBLE. THE STUB OUT SHALL EXTEND BEYOND THE INTERSECTION AREAS OR ROAD CROSSING BY 10 FEET (MIN.) WHERE POSSIBLE.

THRUST BLOCK SIZE CHART

PLATE S-45

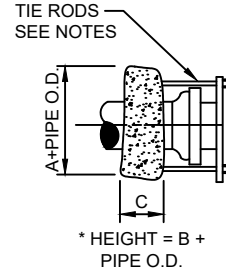
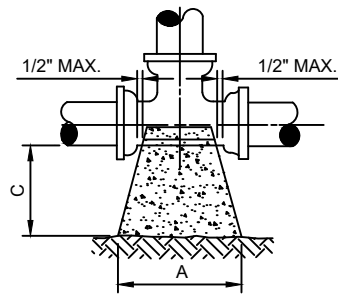

THRUST BLOCK FOR TEES & PLUGS				
SIZE	90° BEND			S.F. BEARING SURFACE
	A	B	C	
4"	16"	16"	18"	1.78
6"	20"	24"	18"	3.33
8"	26"	32"	18"	5.78
10"	32"	40"	18"	8.89
12"	36"	48"	24"	12.00
14"	40"	56"	24"	15.56
16"	48"	60"	24"	20.00
18"	56"	64"	24"	24.89
20"	60"	76"	24"	31.67
24"	72"	90"	24"	45.00
30"	86"	102"	24"	60.67
36"	116"	108"	24"	86.11

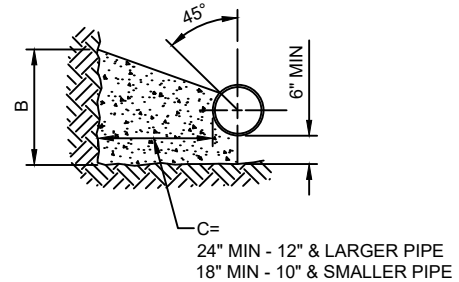
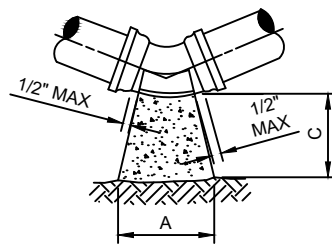

THRUST BLOCK FOR BENDS																
SIZE	90° BEND			S.F. BEARING SURFACE	45° BEND			S.F. BEARING SURFACE	22-1/2° BEND			S.F. BEARING SURFACE	11-1/4° BEND			S.F. BEARING SURFACE
	A	B	C		A	B	C		A	B	C		A	B	C	
4"	16"	16"	18"	1.78	14"	16"	18"	1.56	14"	16"	18"	1.56	14"	16"	18"	1.56
6"	22"	32"	18"	4.89	16"	18"	18"	2.00	14"	16"	18"	1.56	14"	16"	18"	1.56
8"	32"	36"	18"	8.00	24"	28"	18"	4.67	16"	18"	18"	2.00	14"	16"	18"	1.56
10"	36"	46"	18"	11.50	26"	36"	18"	6.50	20"	24"	18"	3.33	14"	18"	18"	1.75
12"	44"	56"	24"	17.11	32"	40"	24"	8.89	24"	30"	24"	5.00	16"	20"	24"	2.22
14"	52"	62"	24"	22.39	36"	48"	24"	12.00	26"	36"	24"	6.50	20"	24"	24"	3.33
16"	58"	72"	24"	29.00	40"	54"	24"	15.00	32"	38"	24"	8.44	22"	26"	24"	3.97
18"	64"	80"	24"	35.56	46"	60"	24"	19.17	36"	42"	24"	10.50	24"	32"	24"	5.33
20"	72"	88"	24"	44.00	52"	66"	24"	23.83	38"	48"	24"	12.67	26"	36"	24"	6.50
24"	96"	96"	24"	36.89	64"	78"	24"	34.67	46"	56"	24"	17.89	32"	40"	24"	8.89
30"	122"	102"	24"	86.11	72"	94"	24"	47.00	56"	62"	24"	24.11	36"	48"	24"	12.00
36"	166"	104"	24"	123.33	88"	108"	24"	66.00	64"	78"	24"	34.67	44"	54"	24"	16.50

NOTES:

- ALL BEARING SURFACES TO BE CARRIED TO UNDISTURBED SOIL.
- THESE TABLES SHOW MINIMUM SIZES FOR THRUST BLOCKS IN GOOD SOIL (A-1 THRU A-3, CLEAN SANDS AND GRAVELS) WITH MINIMUM BEARING CAPACITY OF 2000 psi.
- POOR SOILS A-4 THRU A-8, SILTY SOILS, CLAYS, MUCK AND PEAT WILL REQUIRE LARGER THRUST BLOCKING.
- BOTH CONCRETE THRUST BLOCKS AND TIE RODS MUST BE USED WHEN, IN THE JUDGEMENT OF THE ENGINEER, THE NATURE AND CRITICALITY OF AN INSTALLATION IS SUCH AS TO REQUIRE POSITIVE ASSURANCE OF STABILITY.
- THE USE OF THRUST BLOCKS SHALL BE LIMITED TO SITUATIONS SUCH AS POINT REPAIR WHERE EXPOSING SEVERAL JOINTS OF PIPE IS NOT FEASIBLE DUE TO EXISTING GROUND CONDITIONS.
- CONCRETE COLLARS WITH TIE RODS MAY BE USED ON DEAD END LINES AT THE CONTRACTOR'S DISCRETION. NUMBER OF TIE RODS REQUIRED IS AS FOLLOWS:
 - 3" - 8" DIAMETER MAIN - 2 TIE RODS REQUIRED PER JOINT (3/4" ROD)
 - 10" - 12" DIAMETER MAIN - 4 TIE RODS REQUIRED PER JOINT (3/4" ROD)
 - 14" - 16" DIAMETER MAIN - 6 TIE RODS REQUIRED PER JOINT (3/4" ROD)
 - 18" - 20" DIAMETER MAIN - 8 TIE RODS REQUIRED PER JOINT (3/4" ROD)
 - 24" DIAMETER MAIN - 12 TIE RODS REQUIRED PER JOINT (3/4" ROD)
 - 30" - 36" DIAMETER MAIN - 14 TIE RODS REQUIRED PER JOINT (1" ROD)
 - 42" - 48" DIAMETER MAIN - 16 TIE RODS REQUIRED PER JOINT (1 1/4" ROD)
 - 54" DIAMETER MAIN - 18 TIE RODS REQUIRED PER JOINT (1 1/4" ROD)
- MAXIMUM TEST PRESSURE TO BE 150 PSI.

**SEPARATION REQUIREMENTS FOR WATER,
WASTEWATER AND RECLAIMED WATER MAINS
PLATE S-26**

HORIZONTAL & VERTICAL SEPARATION REQUIREMENTS

PROPOSED UTILITY												
CONFLICTING UTILITY	POTABLE WATER			WASTEWATER GRAVITY AND FORCE MAIN			RECLAIMED WATER			VACUUM SEWERS		
	HORIZ.	VERT.	JOINT SPACING*	HORIZ.	VERT.	JOINT SPACING*	HORIZ.	VERT.	JOINT SPACING*	HORIZ.	VERT.	JOINT SPACING*
POTABLE WATER	3' NOTE 1	12"	3' NOTE 2	6' to 10'	12" NOTE 5	6' NOTE 2	3'	12"	6' NOTE 2	3' to 10'	12"	3' NOTE 2
RECLAIMED WATER	3'	12"	6' NOTE 2	3' NOTE 1	12"	3' NOTE 2	3'	12"	6' NOTE 2	3' NOTE 1	12"	3' NOTE 2
WASTEWATER (GRAVITY AND FORCE MAIN)	6' to 10'	12"	6' NOTE 2	3' NOTE 1	12"	6"	3' NOTE 1	12"	3' NOTE 2	3' NOTE 1	12"	3' NOTE 2
VACUUM SEWERS	3' to 10'	12"	3' NOTE 2	3' NOTE 1	12"	6"	3' NOTE 1	12"	3' NOTE 2	3' NOTE 1	12"	3' NOTE 2
RIGHT OF WAYS	3' NOTE 1	N/A	N/A	3' NOTE 1	N/A	N/A	3' NOTE 1	N/A	N/A	3' NOTE 1	N/A	N/A
PERMANENT STRUCTURES (BUILDINGS, SIGNS, POLES, ETC.)	SEE NOTE 7	N/A	N/A	SEE NOTE 7	N/A	N/A	SEE NOTE 7	N/A	N/A	SEE NOTE 7	N/A	N/A
STORM SEWERS	3' NOTE 1	12"	3' NOTE 2	3' NOTE 1	12"	3' NOTE 2	3' NOTE 1	12"	3' NOTE 2	3' NOTE 1	12"	3' NOTE 2
GAS	3' NOTE 1	12"	3' NOTE 2	3' NOTE 1	12"	3' NOTE 2	3' NOTE 1	12"	3' NOTE 2	3' NOTE 1	12"	3' NOTE 2
TREES	3'-6' NOTE 6	N/A	N/A	3'-6' NOTE 6	N/A	N/A	3'-6' NOTE 6	N/A	N/A	3'-6' NOTE 6	N/A	N/A
ALL OTHER UTILITIES	3' NOTE 1	12"	3' NOTE 2	3' NOTE 1	12"	3' NOTE 2	3' NOTE 1	12"	3' NOTE 2	3' NOTE 1	12"	3' NOTE 2

NOTES:

1. THIS SEPARATION REQUIREMENT IS TO PROVIDE ACCESSIBILITY FOR CONSTRUCTION AND MAINTENANCE. THREE FEET OF HORIZONTAL SEPARATION IS THE MINIMUM FOR PIPES WITH THREE FEET OF COVER. FOR PIPES INSTALLED AT GREATER DEPTH, PROVIDE AN ADDITIONAL FOOT OF SEPARATION FOR EACH ADDITIONAL FOOT OF DEPTH.
2. THE MINIMUM JOINT SPACING REQUIRED FROM CROSSING FROM OTHER UTILITIES WHILE STILL MAINTAINING MINIMUM VERTICAL SEPARATION.
3. DISTANCES GIVEN ARE FROM OUTSIDE OF PIPE TO OUTSIDE OF PIPE.
4. NO WATER PIPE SHALL PASS THROUGH OR COME INTO CONTACT WITH ANY PART OF SANITARY OR STORM WATER MANHOLE OR STRUCTURES.
5. WATER MAIN SHOULD CROSS ABOVE OTHER PIPES WHENEVER POSSIBLE. WHEN WATER MAIN MUST BE BELOW OTHER UTILITY PIPING, THE MINIMUM SEPARATION SHALL BE 12 INCHES.
6. REFER TO SECTION 429, III.4.2.
7. REFER TO SECTION 429, III.4.1 FOR MINIMUM SEPARATION REQUIREMENTS FROM PIPE TO STRUCTURES.

NOTES ON UTILITY SEPARATION REQUIREMENTS - SEWER

PLATE S-27

WATER MAIN AND NON-WATER MAIN SEPARATION REQUIREMENTS - NOTES

1. IT IS REQUIRED THAT "WATER MAINS" BE INSTALLED, CLEANED, DISINFECTED AND HAVE A SATISFACTORY BACTERIOLOGICAL SURVEY PERFORMED IN ACCORDANCE WITH THE LATEST APPLICABLE AWWA STANDARDS, CHAPTER 62-555, F.A.C. AND LATEST JEA WATER AND SEWER STANDARDS. FOR THE PURPOSE OF THIS SECTION, THE PHRASE "WATER MAINS" SHALL MEAN MAINS, INCLUDING TREATMENT PLANT PROCESS PIPING, CONVEYING EITHER RAW, PARTIALLY TREATED, OR FINISHED DRINKING WATER; FIRE HYDRANT LEADS; AND SERVICE LINES THAT HAVE AN INSIDE DIAMETER OF THREE (3) INCHES OR GREATER. IN ADDITION, THE PHRASE "RECLAIMED WATER" REFERS TO THE WATER REGULATED UNDER PART III OF CHAPTER 62-610, F.A.C.
2. NEW OR RELOCATED, UNDERGROUND WATER MAINS SHALL BE LAID TO PROVIDE A HORIZONTAL DISTANCE OF AT LEAST THREE (3) FEET BETWEEN THE OUTSIDE OF THE WATER MAIN AND THE OUTSIDE OF ANY EXISTING OR PROPOSED STORM SEWER, STORMWATER FORCE MAIN, OR PIPELINE CONVEYING RECLAIMED WATER.
3. NEW OR RELOCATED, UNDERGROUND WATER MAINS SHALL BE LAID TO PROVIDE A HORIZONTAL DISTANCE OF AT LEAST SIX (6) FEET, AND PREFERABLY TEN (10) FEET, BETWEEN THE OUTSIDE OF THE WATER MAIN AND THE OUTSIDE OF ANY EXISTING OR PROPOSED GRAVITY OR PRESSURE-TYPE SANITARY SEWER, WASTEWATER FORCE MAIN, OR PIPELINE CONVEYING RECLAIMED WATER. THE MINIMUM HORIZONTAL SEPARATION DISTANCE BETWEEN WATER MAINS AND GRAVITY-TYPE SANITARY SEWERS MAY BE REDUCED TO THREE (3) FEET WHERE THE BOTTOM OF THE WATER MAIN IS LAID AT LEAST SIX (6) INCHES ABOVE THE TOP OF THE SEWER (SPECIAL CASE).
4. NEW OR RELOCATED, UNDERGROUND WATER MAINS CROSSING ANY EXISTING OR PROPOSED GRAVITY OR VACUUM-TYPE SANITARY SEWER OR STORM SEWER SHALL BE LAID SO THE OUTSIDE OF THE WATER MAIN IS AT LEAST SIX (6) INCHES, AND PREFERABLE TWELVE (12) INCHES, ABOVE OR AT LEAST TWELVE (12) INCHES BELOW THE OUTSIDE OF THE OTHER PIPELINE. HOWEVER, IT IS PREFERABLE TO LAY THE WATER MAIN ABOVE THE OTHER PIPELINE.
5. NEW OR RELOCATED, UNDERGROUND WATER MAINS CROSSING ANY EXISTING OR PROPOSED PRESSURE-TYPE SANITARY SEWER, WASTEWATER OR STORMWATER FORCE MAIN, OR PIPELINE CONVEYING RECLAIMED WATER SHALL BE LAID SO THE OUTSIDE OF THE WATER MAIN IS AT LEAST TWELVE (12) INCHES ABOVE OR BELOW THE OUTSIDE OF THE OTHER PIPELINE. HOWEVER, IT IS PREFERABLE TO LAY THE WATER MAIN ABOVE THE OTHER PIPELINE.
6. AT THE UTILITY CROSSINGS DESCRIBED IN NOTES 4 AND 5 ABOVE, ONE FULL LENGTH OF WATER MAIN PIPE SHALL BE CENTERED ABOVE OR BELOW THE OTHER PIPELINE SO THE WATER MAIN JOINTS WILL BE AS FAR AS POSSIBLE FROM THE OTHER PIPELINE. ALTERNATIVELY, AT SUCH CROSSINGS, THE PIPES SHALL BE ARRANGED SO THAT ALL WATER MAIN JOINTS ARE AT LEAST THREE (3) FEET FROM ALL JOINTS IN VACUUM-TYPE SANITARY SEWERS, STORM SEWERS, STORMWATER FORCE MAINS, OR PIPELINES CONVEYING RECLAIMED WATER, AND AT LEAST SIX (6) FEET FROM ALL JOINTS IN GRAVITY OR PRESSURE-TYPE SANITARY SEWERS, WASTEWATER FORCE MAINS, OR PIPELINE CONVEYING RECLAIMED WATER.
7. NEW OR RELOCATED FIRE HYDRANTS SHALL BE LOCATED SO THAT THE HYDRANTS ARE AT LEAST THREE (3) FEET FROM ANY EXISTING OR PROPOSED STORM SEWER, STORMWATER FORCE MAIN, OR PIPELINE CONVEYING RECLAIMED WATER; AT LEAST THREE (3) FEET, AND PREFERABLY TEN (10) FEET, FROM ANY EXISTING OR PROPOSED VACUUM-TYPE SANITARY SEWER; AT LEAST SIX (6) FEET, AND PREFERABLY TEN (10) FEET, FROM ANY EXISTING OR PROPOSED GRAVITY OR PRESSURE-TYPE SANITARY SEWER OR WASTEWATER FORCE MAIN.
8. WHERE AN UNDERGROUND WATER MAIN IS BEING LAID LESS THAN THE REQUIRED MINIMUM HORIZONTAL DISTANCE FROM ANOTHER PIPELINE AND WHERE AN UNDERGROUND WATER MAIN IS CROSSING ANOTHER PIPELINE AND JOINTS IN THE WATER MAIN ARE BEING LOCATED LESS THAN THE REQUIRED MINIMUM DISTANCE FROM JOINTS IN THE OTHER PIPELINE, THE CONTRACTOR SHALL CONSULT THE DESIGN ENGINEER TO OBTAIN APPROVAL OF ANY ALTERNATIVE CONSTRUCTION METHODS, PRIOR TO CONSTRUCTION.

ADJUSTMENT OVER EXISTING UTILITIES MECHANICAL RESTRAINTS

PLATE S-39

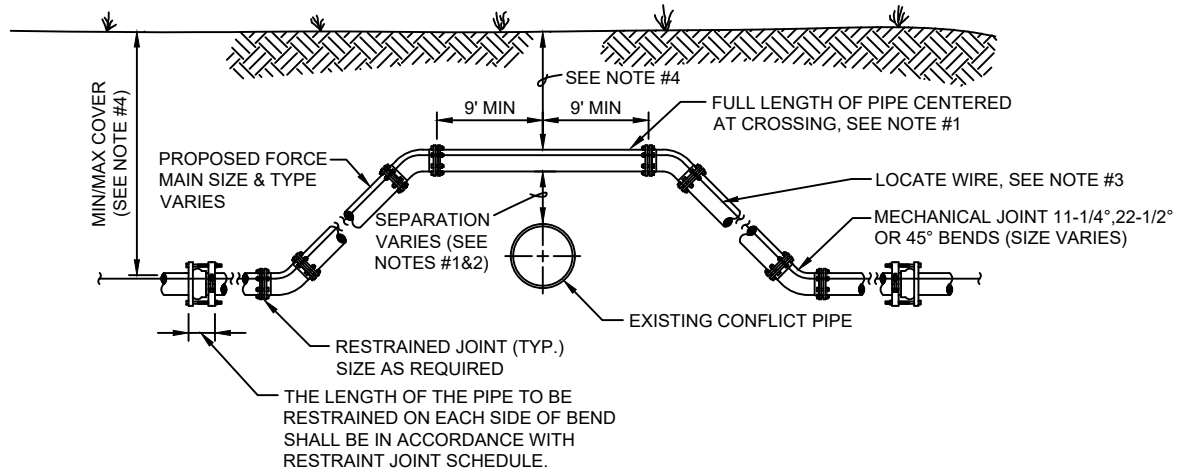

CASE "A" CROSSING

NOTES:

1. IF EXISTING CONFLICT PIPE IS A WATER OR RECLAIMED WATER MAIN, 12-INCHES OF SEPARATION IS REQUIRED. A FULL LENGTH OF PIPE SHALL BE CENTERED OVER EXISTING UTILITY MAIN TO PROVIDE MAXIMUM JOINT SPACING FOR ALL CROSSINGS.
2. FOR OTHER LOCATION LIMITATIONS SEE DETAIL (S-26 & S-27).
3. LOCATING WIRE REQUIRED: SEE DETAIL S-49.
4. THE COVER FOR PIPING LESS THAN 24" SIZE SHALL BE 30" (MIN) IN UNPAVED AREAS, 36" (MIN) IN PAVED AREAS AND A MAXIMUM COVER OF 60", UNLESS PRE-APPROVED BY JEA. THE COVER FOR PIPING 24" SIZE AND LARGER SHALL BE 36" (MIN) IN PAVED AND UNPAVED AREAS AND A MAXIMUM COVER OF 84", UNLESS APPROVED BY JEA.
5. THE SOILS BETWEEN THE MAIN AND THE CONFLICT PIPE SHALL BE COMPACTED TO 98% OF THE MAXIMUM DENSITY AS DETERMINED BY THE LABORATORY MODIFIED PROCTOR TEST ASTM D 1557.

ADJUSTMENT OVER EXISTING UTILITIES TIE RODS

PLATE S-40

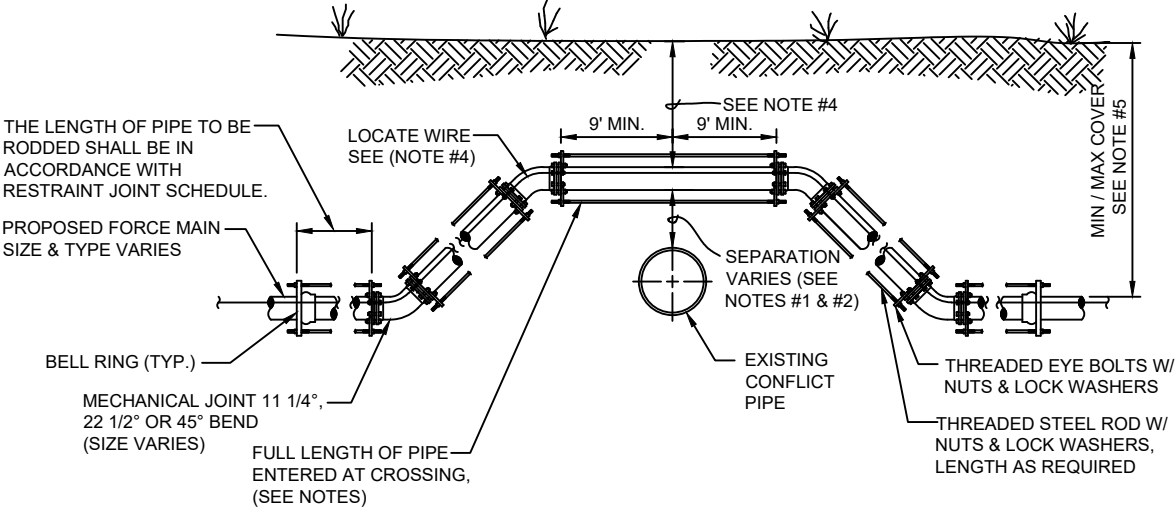

CASE "A" CROSSING

NOTES:

- IF EXISTING CONFLICT PIPE IS A WATER MAIN 12-INCHES OF SEPARATION IS REQUIRED. A FULL LENGTH OF PIPE SHALL BE CENTERED OVER EXISTING UTILITY MAIN TO PROVIDE MAXIMUM JOINT SPACING FOR ALL CROSSINGS.
- FOR OTHER LOCATION LIMITATIONS SEE DETAIL (S-26 & S-27).
- NUMBER OF TIE RODS REQUIRED IS AS FOLLOWS:

3" - 8"	DIAMETER MAIN - 2 TIE RODS REQUIRED PER JOINT (3/4" ROD)
10" - 12"	DIAMETER MAIN - 4 TIE RODS REQUIRED PER JOINT (3/4" ROD)
14" - 16"	DIAMETER MAIN - 6 TIE RODS REQUIRED PER JOINT (3/4" ROD)
18" - 20"	DIAMETER MAIN - 8 TIE RODS REQUIRED PER JOINT (3/4" ROD)
24"	DIAMETER MAIN - 12 TIE RODS REQUIRED PER JOINT (3/4" ROD)
30" - 36"	DIAMETER MAIN - 14 TIE RODS REQUIRED PER JOINT (1" ROD)
42" - 48"	DIAMETER MAIN - 16 TIE RODS REQUIRED PER JOINT (1 1/4" ROD)
54"	DIAMETER MAIN - 18 TIE RODS REQUIRED PER JOINT (1 1/4" ROD)
- LOCATING WIRE REQUIRED: SEE DETAIL S-49.
- THE COVER FOR PIPING LESS THAN 24" SIZE SHALL BE 30" (MIN) IN UNPAVED AREAS, 36" (MIN) IN PAVED AREAS AND A MAXIMUM COVER OF 60", UNLESS PRE-APPROVED BY JEA. THE COVER FOR PIPING 24" SIZE AND LARGER SHALL BE 36" (MIN) IN PAVED AND UNPAVED AREAS AND A MAXIMUM COVER OF 84", UNLESS APPROVE BY JEA.
- THE SOILS BETWEEN THE MAIN AND THE CONFLICT PIPE SHALL BE COMPACTED TO 98% OF THE MAXIMUM DENSITY AS DETERMINED BY THE LABORATORY MODIFIED PROCTOR TEST ASTM D 1557.

ADJUSTMENT UNDER EXISTING UTILITIES MECHANICAL RESTRAINTS

PLATE S-41

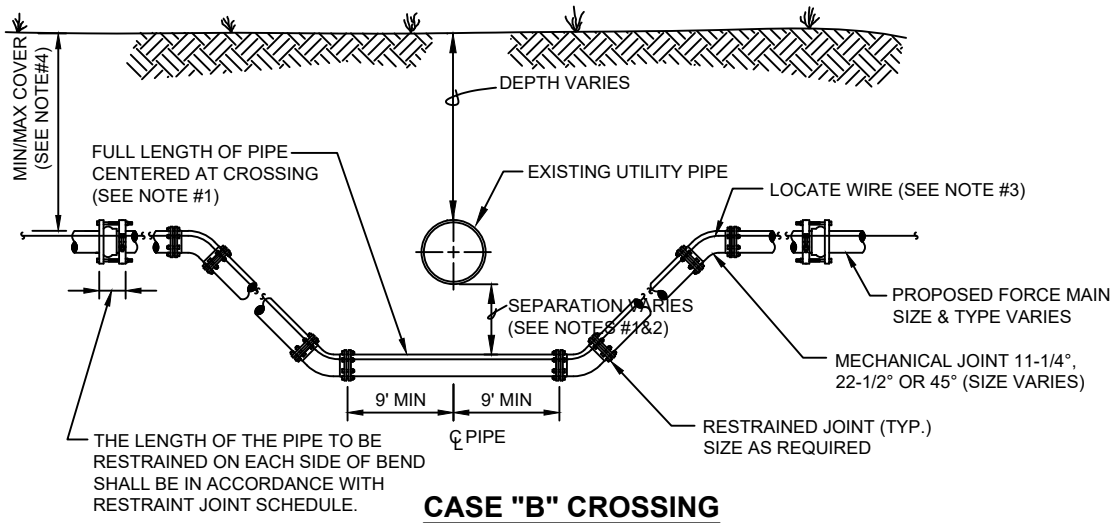

NOTES:

1. IF EXISTING CONFLICT PIPE IS A WATER OR RECLAIMED WATER MAIN, 12-INCHES OF SEPARATION IS REQUIRED. A FULL LENGTH OF PIPE SHALL BE CENTERED OVER EXISTING UTILITY MAIN TO PROVIDE MAXIMUM JOINT SPACING FOR ALL CROSSINGS.
2. FOR OTHER LOCATION LIMITATIONS SEE DETAIL (S-26 & S-27).
3. LOCATING WIRE REQUIRED: SEE DETAIL S-49.
4. THE COVER FOR PIPING LESS THAN 24" SIZE SHALL BE 30" (MIN) IN UNPAVED AREAS, 36" (MIN) IN PAVED AREAS AND A MAXIMUM COVER OF 60", UNLESS PRE-APPROVED BY JEA. THE COVER FOR PIPING 24" SIZE AND LARGER SHALL BE 36" (MIN) IN PAVED AND UNPAVED AREAS AND A MAXIMUM COVER OF 84", UNLESS APPROVED BY JEA.
5. THE SOILS BETWEEN THE MAIN AND THE CONFLICT PIPE SHALL BE COMPACTED TO 98% OF THE MAXIMUM DENSITY AS DETERMINED BY THE LABORATORY MODIFIED PROCTOR TEST ASTM D 1557.

ADJUSTMENT UNDER EXISTING UTILITIES TIE RODS

PLATE S-42

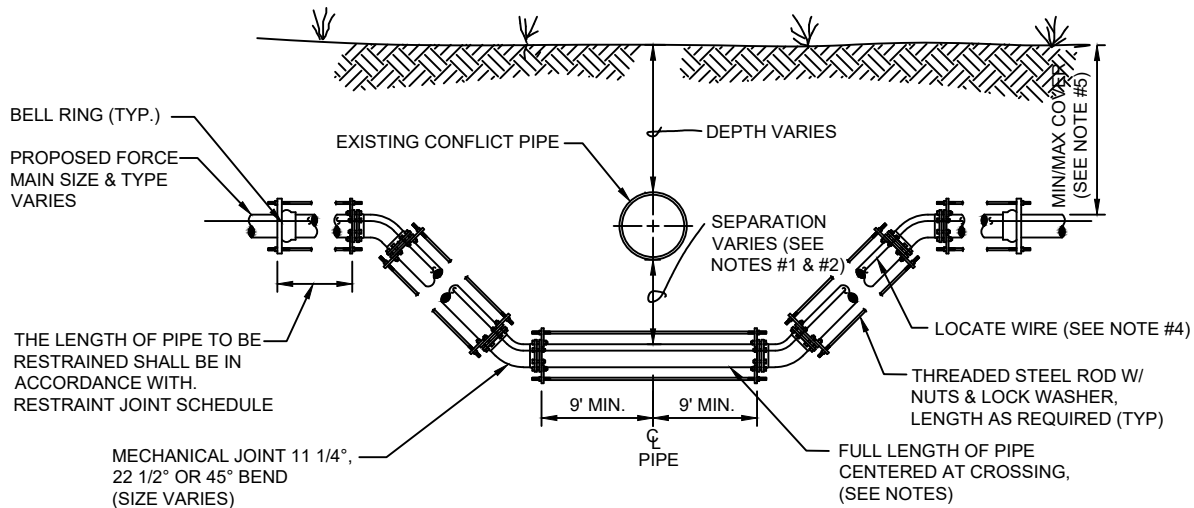

CASE "B" CROSSING

NOTES:

1. IF EXISTING CONFLICT PIPE IS A WATER OR RECLAIM WATER MAIN, 12-INCHES OF SEPARATION IS REQUIRED. A FULL LENGTH OF PIPE SHALL BE CENTERED OVER EXISTING UTILITY MAIN TO PROVIDE MAXIMUM JOINT SPACING FOR ALL CROSSINGS.
2. FOR OTHER LOCATION LIMITATIONS SEE DETAIL (S-26 & S-27).
3. NUMBER OF TIE RODS REQUIRED IS AS FOLLOWS:

3" - 8"	DIAMETER MAIN - 2 TIE RODS REQUIRED PER JOINT (3/4" ROD)
10" - 12"	DIAMETER MAIN - 4 TIE RODS REQUIRED PER JOINT (3/4" ROD)
14" - 16"	DIAMETER MAIN - 6 TIE RODS REQUIRED PER JOINT (3/4" ROD)
18" - 20"	DIAMETER MAIN - 8 TIE RODS REQUIRED PER JOINT (3/4" ROD)
24"	DIAMETER MAIN - 12 TIE RODS REQUIRED PER JOINT (3/4" ROD)
30" - 36"	DIAMETER MAIN - 14 TIE RODS REQUIRED PER JOINT (1" ROD)
42" - 48"	DIAMETER MAIN - 16 TIE RODS REQUIRED PER JOINT (1 1/4" ROD)
54"	DIAMETER MAIN - 18 TIE RODS REQUIRED PER JOINT (1 1/4" ROD)
4. LOCATING WIRE REQUIRED: SEE DETAIL S-49.
5. THE COVER FOR PIPING LESS THAN 24" SIZE SHALL BE 30" (MIN) IN UNPAVED AREAS, 36" (MIN) IN PAVED AREAS AND A MAXIMUM COVER OF 60", UNLESS PRE-APPROVED BY JEA. THE COVER FOR PIPING 24" SIZE AND LARGER SHALL BE 36" (MIN) IN PAVED AND UNPAVED AREAS AND A MAXIMUM COVER OF 84", UNLESS APPROVE BY JEA.
6. THE SOILS BETWEEN THE MAIN AND THE CONFLICT PIPE SHALL BE COMPACTED TO 98% OF THE MAXIMUM DENSITY AS DETERMINED BY THE LABORATORY MODIFIED PROCTOR TEST. ASTM D 1557.

ADJUSTMENT UNDER EXISTING UTILITIES PIPE JOINT DEFLECTION

PLATE S-47

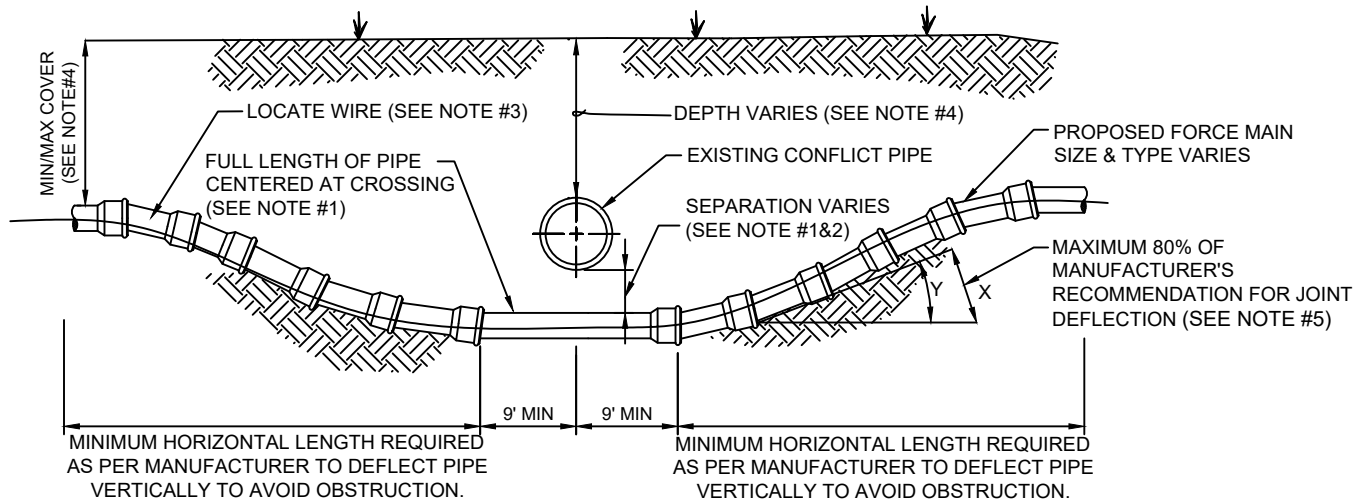

CASE "B" CROSSING

MAXIMUM ALLOWED OFFSET FOR PIPE BY JOINT DEFLECTION

PVC PIPE

PIPE SIZE (IN.)	(X) MAX. OFFSET (IN.)	(Y) ANGLE AT ONE BELL	RESULTING RADIUS OF CURVE WITH 20FT. LENGTHS
2	30	7°	158 FT
4	10	2.4°	480 FT
6	10	2.4°	480 FT
8	10	2.4°	480 FT
10	10	2.4°	480 FT
12	8.5	2°	564 FT
14 - 24	5	1.2°	960 FT
30 - 48	3.25	0.8°	1477 FT

NOTES:

- IF EXISTING CONFLICT PIPE IS A WATER MAIN OR RECLAIM WATER MAIN, 12-INCHES OF SEPARATION IS REQUIRED. A FULL LENGTH OF PIPE SHALL BE CENTERED OVER EXISTING UTILITY MAIN TO PROVIDE MAXIMUM JOINT SPACING FOR ALL CROSSING.
- FOR OTHER LOCATION LIMITATIONS SEE DETAIL (S-26 & S-27).
- LOCATING WIRE REQUIRED: SEE DETAIL S-49.
- THE COVER OVER ALL PIPING LESS THAN 24" SIZE SHALL BE A MINIMUM OF 30" IN UNPAVED AREAS AND 36" IN PAVED AREAS WITH A MAXIMUM COVER OF 60" UNLESS APPROVED OTHERWISE BY JEA. COVER FOR PIPING 24" SIZE AND LARGER SHALL BE MINIMUM OF 36" (PAVED AND UNPAVED) AND MAXIMUM OF 84" UNLESS APPROVED OTHERWISE BY JEA. THE SOILS BETWEEN THE NEW MAIN AND THE CONFLICT PIPE SHALL BE COMPACTED TO 98% OF THE MAXIMUM DENSITY AS DETERMINED BY THE LABORATORY MODIFIED PROCTOR TEST ASTM D 1557.
- JEA ONLY ALLOWS 80% OF THE PIPE MANUFACTURER'S RECOMMENDATION FOR JOINT DEFLECTION. BENDING THE PIPE BARREL IS NOT ALLOWED. UNLESS OTHERWISE APPROVED BY JEA, THE MAXIMUM ARE LISTED IN TABLE BELOW. ONLY MANUAL FORCE CAN BE UTILIZED TO OBTAIN THESE JOINT DEFLECTION. ALL OFFSETS ARE BASED ON MINIMUM 20LF PIPE LENGTH.

ADJUSTMENT OVER EXISTING UTILITIES PIPE JOINT DEFLECTION

PLATE S-48

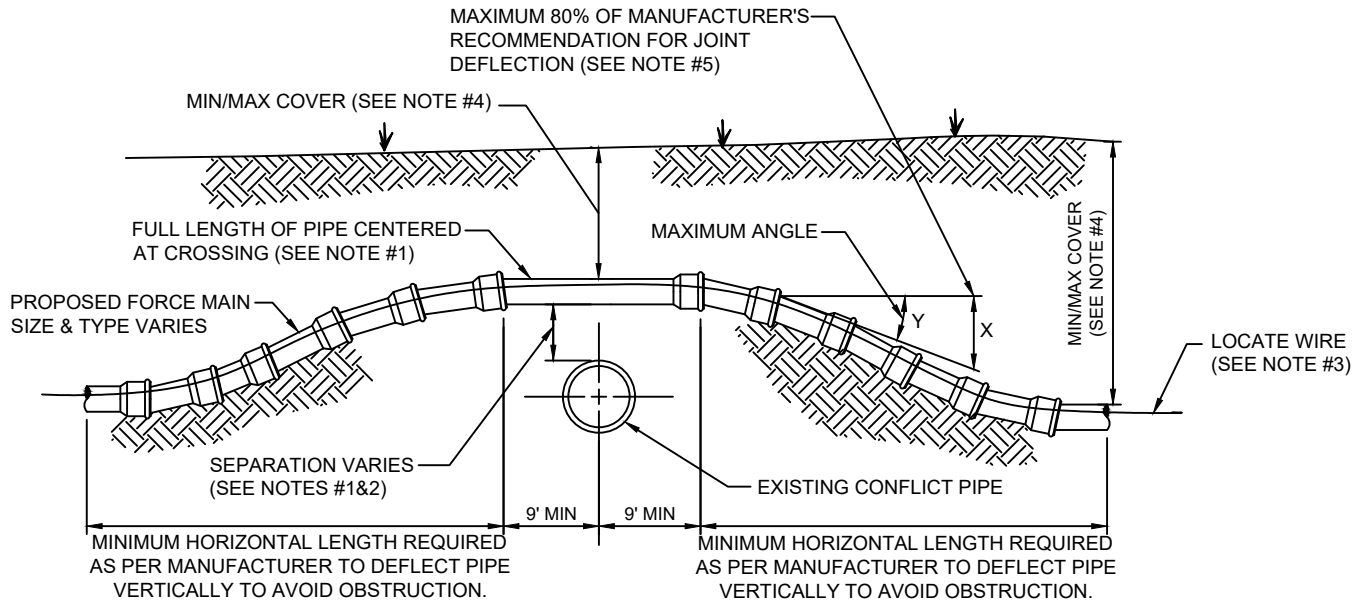

CASE "A" CROSSING

MAXIMUM ALLOWED OFFSET FOR PIPE BY JOINT DEFLECTION

PVC PIPE

PIPE SIZE (IN.)	(X) MAX. OFFSET (IN.)	(Y) ANGLE AT ONE BELL	RESULTING RADIUS OF CURVE WITH 20FT. LENGTHS
2	30	7°	158 FT
4	10	2.4°	480 FT
6	10	2.4°	480 FT
8	10	2.4°	480 FT
10	10	2.4°	480 FT
12	8.5	2°	564 FT
14 - 24	5	1.2°	960 FT
30 - 48	3.25	0.8°	1477 FT

NOTES:

- IF EXISTING CONFLICT PIPE IS A WATER MAIN OR RECLAIM WATER MAIN, 12-INCHES OF SEPARATION IS REQUIRED. A FULL LENGTH OF PIPE SHALL BE CENTERED OVER EXISTING UTILITY MAIN TO PROVIDE MAXIMUM JOINT SPACING FOR ALL CROSSING.
- FOR OTHER LOCATION LIMITATIONS SEE DETAIL (S-26 & S-27).
- LOCATING WIRE REQUIRED: SEE DETAIL S-49.
- THE COVER OVER ALL PIPING LESS THAN 24" SIZE SHALL BE A MINIMUM OF 30" IN UNPAVED AREAS AND 36" IN PAVED AREAS WITH A MAXIMUM COVER OF 60" UNLESS APPROVED OTHERWISE BY JEA. COVER FOR PIPING 24" SIZE AND LARGER SHALL BE MINIMUM OF 36" (PAVED AND UNPAVED) AND MAXIMUM OF 84" UNLESS APPROVED OTHERWISE BY JEA. THE SOILS BETWEEN THE NEW MAIN AND THE CONFLICT PIPE SHALL BE COMPACTED TO 98% OF THE MAXIMUM DENSITY AS DETERMINED BY THE LABORATORY MODIFIED PROCTOR TEST ASTM D 1557.
- JEA ONLY ALLOWS 80% OF THE PIPE MANUFACTURER'S RECOMMENDATION FOR JOINT DEFLECTION. BENDING THE PIPE BARREL IS NOT ALLOWED. UNLESS OTHERWISE APPROVED BY JEA, THE MAXIMUM ARE LISTED IN TABLE BELOW. ONLY MANUAL FORCE CAN BE UTILIZED TO OBTAIN THESE JOINT DEFLECTION. ALL OFFSETS ARE BASED ON MINIMUM 20LF PIPE LENGTH.

TYPICAL CASING DETAIL - SEWER

PLATE S-25

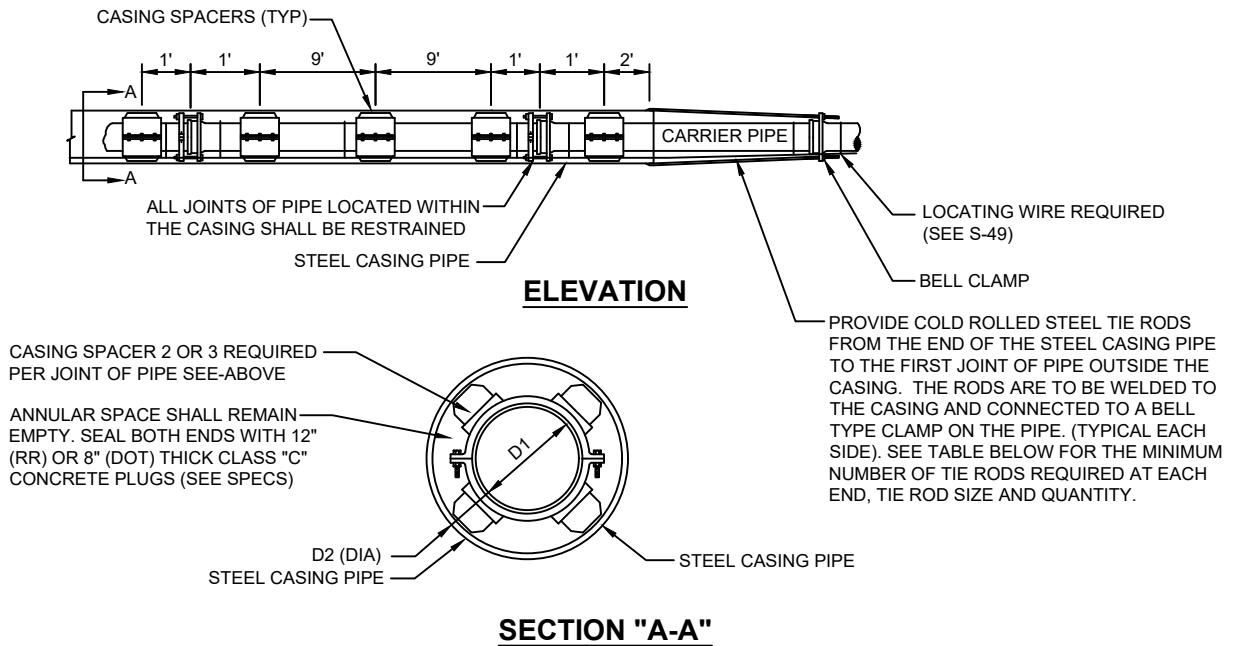

CARRIER TYPE AND CASING PIPE SIZES (MIN) IN INCHES														
CARRIER PIPE NO. DIA. (D ₁)	4	6	8	10	12	14	16	18	20	24	30	36	42	48
CASING PIPE NOM. DIA. (D ₂)	14	16	20	20	24	30	30	30	36	42	48	54	60	66
WALL THICKNESS RAILROAD-(FEC)	0.25	1.25	0.375	0.375	0.375	0.50	0.50	0.50	0.562	0.625	0.625	0.688	0.781	0.781
WALL THICKNESS RAILROAD-(CSX)	0.25	0.281	0.375	0.375	0.375	0.469	0.469	0.469	0.562	0.625	0.688	0.781	0.844	0.938
WALL THICKNESS DOT	0.25	0.25	0.25	0.25	0.25	0.312	0.312	0.312	0.375	0.50	0.50	0.50	0.50	0.50
NUMBER OF TIE RODS (EACH END)	2	2	2	4	4	6	6	8	8	12	14	14	16	16
TIE ROD SIZE (DIA.)	3/4"	3/4"	3/4"	3/4"	3/4"	3/4"	3/4"	3/4"	3/4"	3/4"	1"	1"	1 1/4"	1 1/4"

PIPE MAIN CROSSINGS FOR RAILROADS OR HIGHWAYS

NOTES:

1. MIN. COVER TO TOP OF CASING; a) FDOT-3.0' b) RAILROAD-5.5' TO BASE OF RAIL, 4.5' FOR SECONDARY OR INDUSTRIAL TRACKS. EXCEPT FOR F.E.C. (SEE NOTE 3)
2. THE INSIDE DIAMETER OF THE CASING PIPE SHALL BE A MINIMUM OF 4 INCHES GREATER THAN THE OUTSIDE DIAMETER OF THE CARRIER PIPE BELL OR COUPLING. HOWEVER, A MINIMUM OF 6 INCHES IS REQUIRED FOR FLORIDA EAST COAST R.R. CROSSINGS.
3. THE MINIMUM COVER FOR CASING UNDER FLORIDA EAST COAST RAILROAD SHALL BE 5.0 FEET BELOW THE BOTTOM OF TIES FOR ALL TRACKS.
4. ALL JOINTS WITHIN CARRIES PIPE SHALL BE MECHANICAL RESTRAINED JOINTS.
5. FOR STREET USES WHICH ARE NOT DOT OR RAILROAD, USE DOT CASING THICKNESS UNLESS OTHERWISE INDICATED BY ENGINEER.
6. CASING PIPE SHALL BE FURNISHED IN NOMINAL 8 FOOT LENGTHS (MIN.) UNLESS OTHERWISE INDICATED ON THE DRAWING OR APPROVED BY JEA.
7. PIPE TO BE USED AS A CASING SHALL CONFORM TO EITHER ASTM STANDARD A139 FOR "ELECTRIC FUSION (ARC) WELDED STEEL PIPE". WITH A MINIMUM YIELD STRENGTH OF 35,000 PSI OR "API SPECIFICATION API-5LX, GRADE X-42 WELDED STEEL PIPE".

TYPICAL SPLIT CASING DETAIL - SEWER

PLATE S-25A

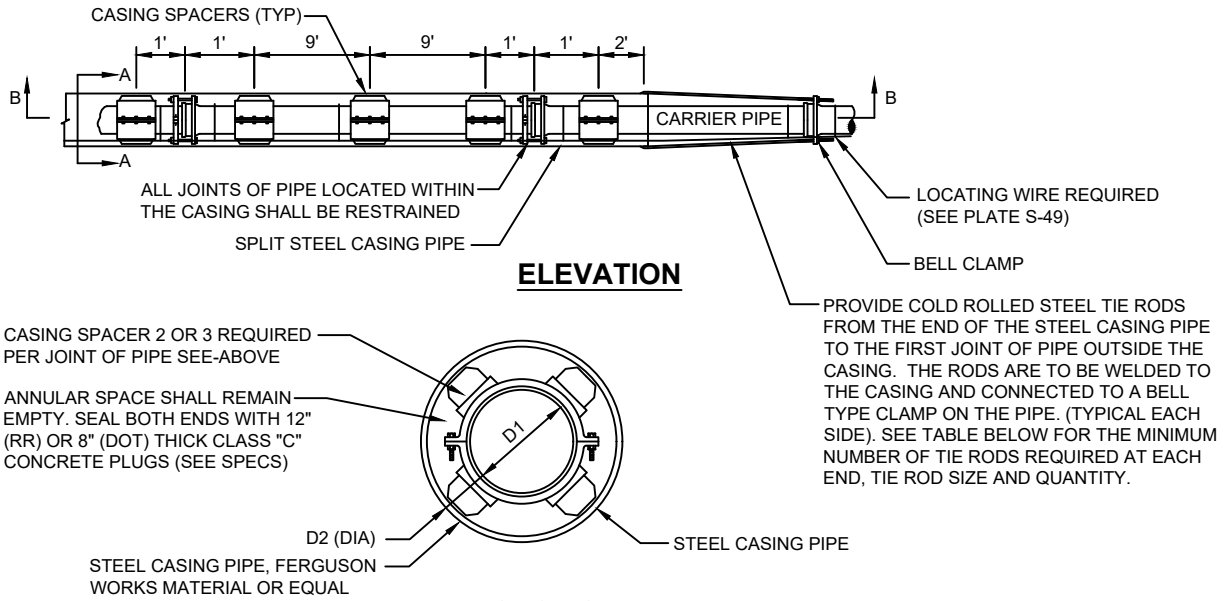

SECTION "A-A"

CARRIER TYPE AND CASING PIPE SIZES (MIN) IN INCHES														
CARRIER PIPE NO. DIA. (D ₁)	4	6	8	10	12	14	16	18	20	24	30	36	42	48
CASING PIPE NOM. DIA. (D ₂)	14	16	20	20	24	30	30	30	36	42	48	54	60	66
WALL THICKNESS RAILROAD-(FEC)	0.25	1.25	0.375	0.375	0.375	0.50	0.50	0.50	0.562	0.625	0.625	0.688	0.781	0.781
WALL THICKNESS RAILROAD-(CSX)	0.25	0.281	0.375	0.375	0.375	0.469	0.469	0.469	0.562	0.625	0.688	0.781	0.844	0.938
WALL THICKNESS DOT	0.25	0.25	0.25	0.25	0.25	0.312	0.312	0.312	0.375	0.50	0.50	0.50	0.50	0.50
NUMBER OF TIE RODS (EACH END)	2	2	2	4	4	6	6	8	8	12	14	14	16	16
TIE ROD SIZE (DIA.)	3/4"	3/4"	3/4"	3/4"	3/4"	3/4"	3/4"	3/4"	3/4"	3/4"	1"	1"	1 1/4"	1 1/4"

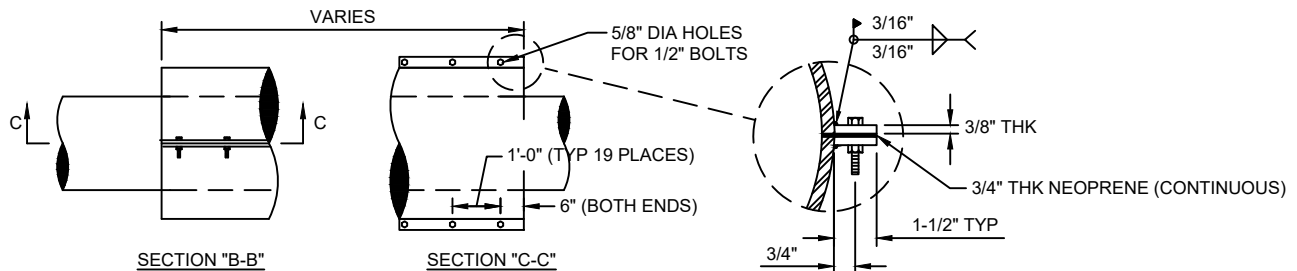

MATERIAL: PIPE - ASTM A53, GRADE B, ERW, STD WALL, CARBON STEEL
 PLATE - STM A36, GRADE B, CARBON STEEL (THICKNESS AS NOTED)

WELDS ALL WELDS SHALL BE PERFORMED BY A CERTIFIED WELDER

LININGS/COATINGS: INTERIOR - BARE
 EXTERIOR - BARE

PIPE MAIN FOR CROSSINGS USING SPLIT CASING PIPE

NOT ALLOWED UNDER RAILROADS

NOTES

1. NOT ALLOWED UNDER RAILROADS.
2. THE INSIDE DIAMETER OF THE CASING PIPE SHALL BE A MINIMUM OF 4 INCHES GREATER THAN THE OUTSIDE DIAMETER OF THE CARRIER PIPE BELL OR COUPLING.
3. ALL JOINTS WITHIN CARRIES PIPE SHALL BE MECHANICAL RESTRAINED JOINTS.
4. FOR STREET USES WHICH ARE NOT DOT OR RAILROAD, USE DOT CASING THICKNESS UNLESS OTHERWISE INDICATED BY ENGINEER.
5. CASING PIPE SHALL BE FURNISHED IN NOMINAL 8 FOOT LENGTHS (MIN.) UNLESS OTHERWISE INDICATED ON THE DRAWING OR APPROVED BY JEA.
6. PIPE TO BE USED AS A CASING SHALL CONFORM TO EITHER ASTM STANDARD A139 FOR "ELECTRIC FUSION (ARC) WELDED STEEL PIPE". WITH A MINIMUM YIELD STRENGTH OF 35,000 PSI OR "API SPECIFICATION API-5LX, GRADE X-42 WELDED STEEL PIPE".

BRIDGE DECK PIPE HANGER DETAIL

PLATE S-28

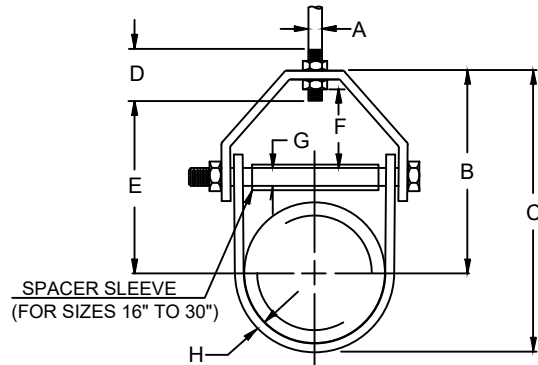

PIPE SIZE	MAX LOAD	WEIGHT	ROD SIZE A	B	C	ROD TAKE OUT E	ADJUST. F	G	H WIDTH LOWER
4	1430	1.51	5/8	5-9/16	7-13/16	4-1/2	1-11/16	3/8	1-1/4
6	1940	3.10	3/4	6-15/16	10-1/4	5-3/4	1-11/16	1/2	1-7/16
8	2000	4.75	3/4	8-3/8	12-11/16	7-3/16	2	1/2	1-7/16
10	3600	8.60	7/8	9-7/8	15-1/4	8-7/16	2-1/8	5/8	1-3/4
12	3800	11.20	7/8	11-9/16	17-15/16	10-1/8	2-13/16	5/8	2
16	4600	19.85	1	14	22	12	2-3/4	1	2-1/2
20	4800	40.33	1-1/4	17-9/16	27-9/16	15-3/16	3-7/8	1-1/4	3
24	4800	49.83	1-1/4	19-13/16	31-13/16	17-5/16	3-7/8	1-1/4	3
30	6000	70.18	1-1/4	24-3/16	39-3/16	21-9/16	5-1/8	1-1/4	3

NOTES :

1. ALL HANGER COMPONENTS SHALL BE 316 STAINLESS STEEL UNLESS OTHERWISE NOTED. ALL CUT ENDS SHALL HAVE ROUNDED CORNERS.
2. PROVIDE A HANGER AT EACH PIPE BELL. ADDITIONAL HANGERS SHALL BE SPACED AT TEN (10) FOOT CENTERS (MAX).
3. PIPE HANGERS LARGER THAN 12" SIZE SHALL BE SPECIFICALLY DESIGNED FOR HORIZONTAL AND VERTICAL STRUCTURAL SUPPORT. FOR LARGER MAINS, HORIZONTAL SUPPORT MAY BE ACHIEVED BY EXTENDING THE BOTTOM ANGLE TO SPAN BETWEEN TWO EXISTING CONCRETE BEAMS (NOT DIRECTLY CONNECTED TO CONCRETE BEAMS).
4. THE DIMENSION PROVIDED ABOVE MAY VARY DEPENDING ON ACTUAL FIELD CONDITIONS.
5. FOR CROSSINGS OVER 250 LINEAR FEET, THE USE OF FLEXIBLE EXPANSION JOINTS SHALL BE UTILIZED.

SIDEWALL PIPE HANGER DETAIL

PLATE S-35

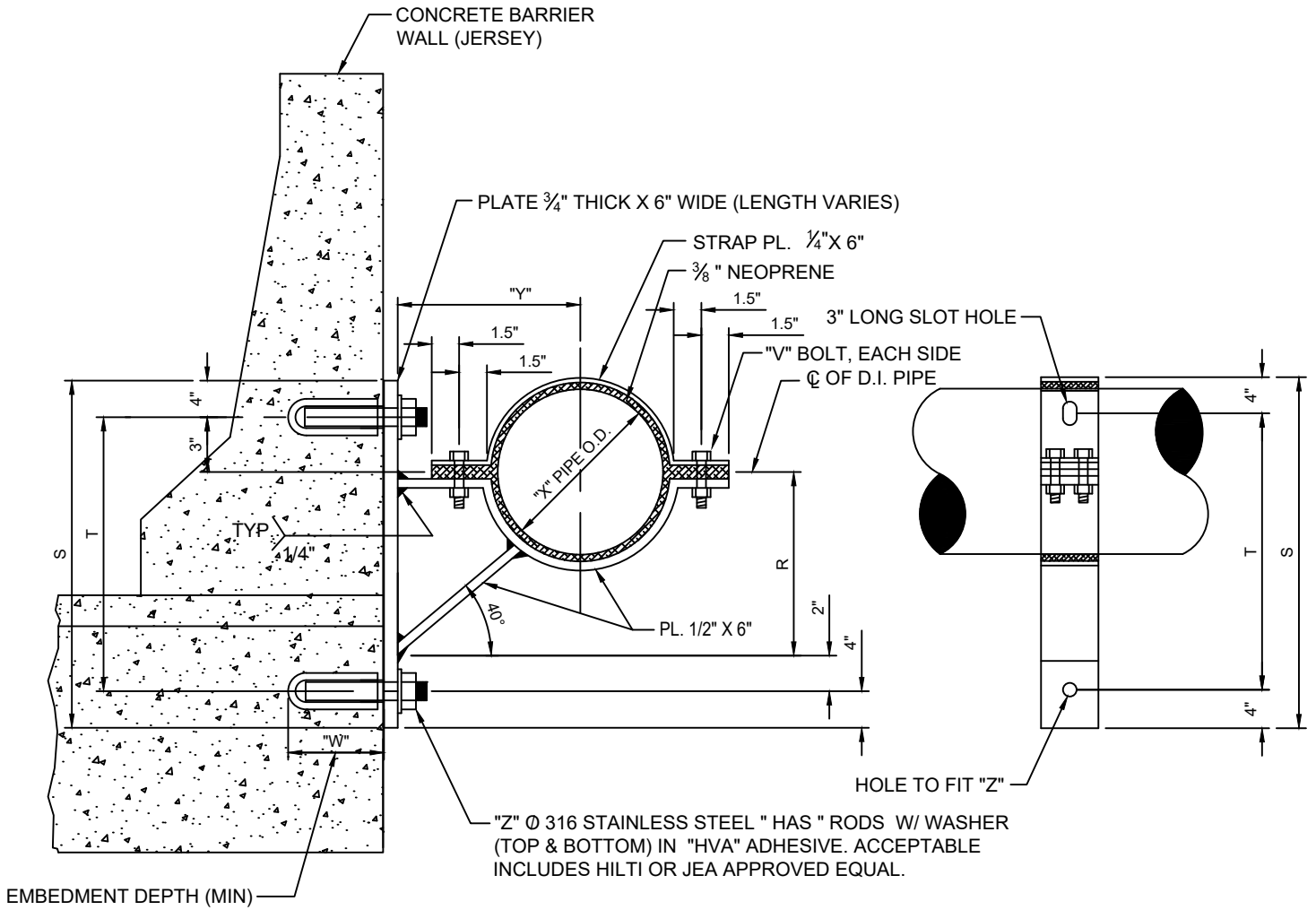

CROSS-SECTION

PROFILE

PIPE SIZE	4"	6"	8"	10"	12"	16"	20"	24"
X	4.80"	6.90"	9.05"	11.10"	13.20"	17.40"	21.60"	25.80"
Y	8"	9"	10"	12"	13"	15"	17"	19"
Z	$\frac{3}{4}$ "	$\frac{3}{4}$ "	$\frac{3}{4}$ "	1"	1"	1"	1 $\frac{1}{4}$ "	1 $\frac{1}{4}$ "
W	6.625"	6.625"	6.625"	8.25"	8.25"	8.25"	12"	12"
V	1/2"	1/2"	1/2"	1/2"	1/2"	3/4"	3/4"	3/4"
R	6.72"	7.55"	8.39"	10.07"	10.91"	12.59"	14.27"	15.94"
S	19.71"	20.55"	21.39"	23.07"	23.91"	25.59"	27.26"	28.94"
T	11.72"	12.55"	13.39"	15.07"	15.91"	17.58"	19.26"	20.94"

NOTES :

1. ALL WELDS TO BE PERFORMED BY A CERTIFIED STRUCTURAL WELDER.
2. ALL SUPPORT BRACKET MEMBERS SHALL BE HOT DIPPED GALVANIZED AFTER FABRICATION.
3. ALL NUTS, BOLTS, AND WASHERS SHALL BE 316 STAINLESS STEEL.
4. THE SPACING OF SIDEWALL PIPE SUPPORTS SHALL BE SPECIFICALLY DESIGNED BASED UPON MANY FACTS INCLUDING PIPE SIZE AND MATERIAL EMBEDMENT LIMITATIONS. UNLESS APPROVED OTHERWISE BY JEA, IN NO CASE SHALL THE SPACING OF PIPE SUPPORTS EXCEED TWENTY (20) FEET ON-CENTER FOR PIPE SIZES TWELVE (12) INCH AND SMALLER AND TEN (10) FEET ON-CENTER FOR PIPE SIZES GREATER THAN TWELVE (12) INCHES.

PIPE SUPPORT & POLE ASSEMBLY FOR FORCE MAIN

PLATE S-36

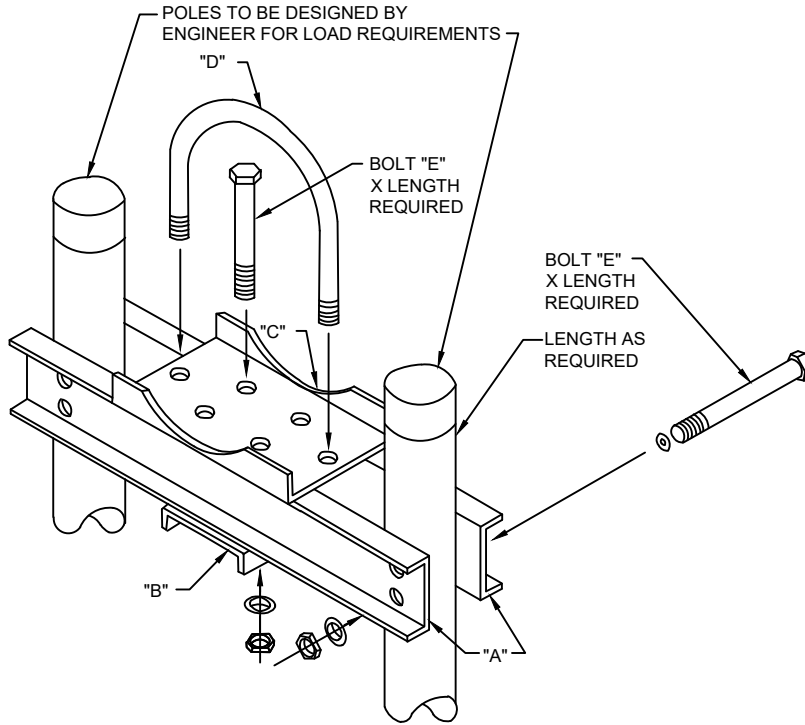

MATERIAL SCHEDULE

ITEM	PIPE 4"-14"		PIPE 16"-24"	
A	8"	[11.5	12"	[25.0
B	10"	[15.3	12"	[25.0
C	12"	[25.0	12"	[25.0
D	1/2" U-BOLT		1-1/8" U-BOLT	
E	3/4" U-BOLT		1-1/8" U-BOLT	

NOTES:

1. ALL PARTS AND FITTINGS TO BE HOT DIPPED GALVANIZED AFTER FABRICATION SEE PLATE S-37 FOR ADDITIONAL DETAILS.
2. AT A MINIMUM, ONE PIPE SUPPORT SHALL BE PROVIDED FOR EACH LENGTH OF (D.I.P.) PIPE UNLESS LONG-SPAN (D.I.P.) PIPE ASSEMBLIES ARE PROVIDED.

PIPE SUPPORT DETAILS FOR POLE ASSEMBLY

PLATE S-37

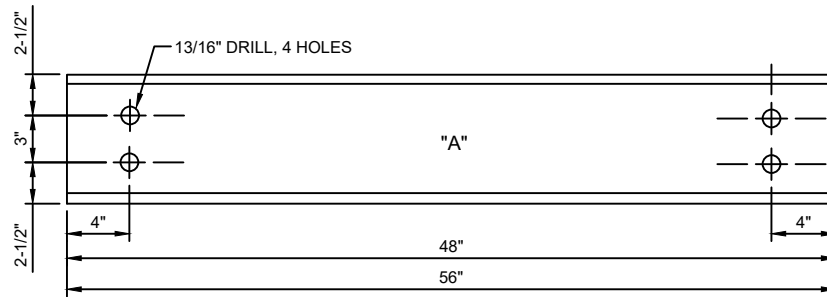

"A" STANDARD 8" CHANNEL 11.5 LBS.

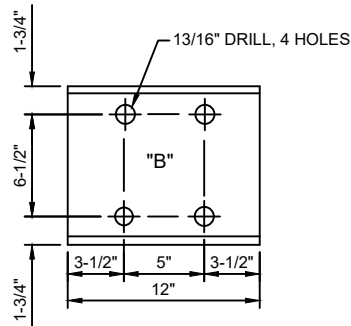

"B" STANDARD 10" CHANNEL 15.3 LBS.

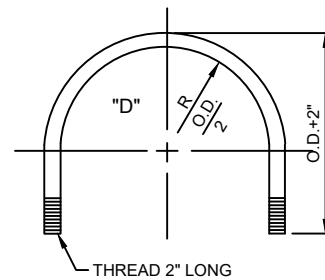

"D" 1/2" U-BOLT

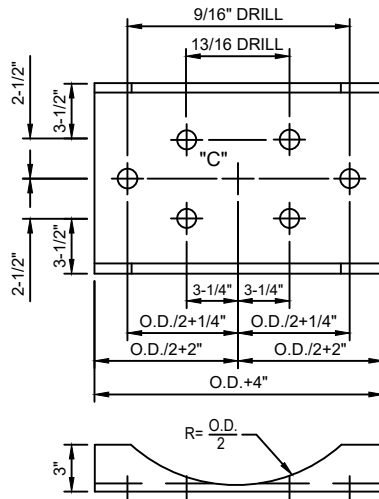

"C" STANDARD 12" CHANNEL 25 LBS.

D.I. PIPE	O.D. APPROX
3"	4.71"
4"	5.55"
6"	7.65"
8"	9.80"
10"	11.85"
12"	13.95"
14"	16.05"
16"	18.15"
18"	20.25"
20"	22.35"
24"	26.55"

TABLE

NOTES:

- FOR PIPE 16" AND LARGER, UTILIZE CHANNEL SIZES AS SCHEDULED ON PLATE S-36, BUT CUSTOMIZE BOLT PATTERN DIMENSIONS TO FIT PIPE SIZE. SEE PLATE S-36 FOR ASSEMBLY LAYOUT.

SWABBING PORT AND CLEAN OUT VAULT DETAIL-PLAN

PLATE S-54A

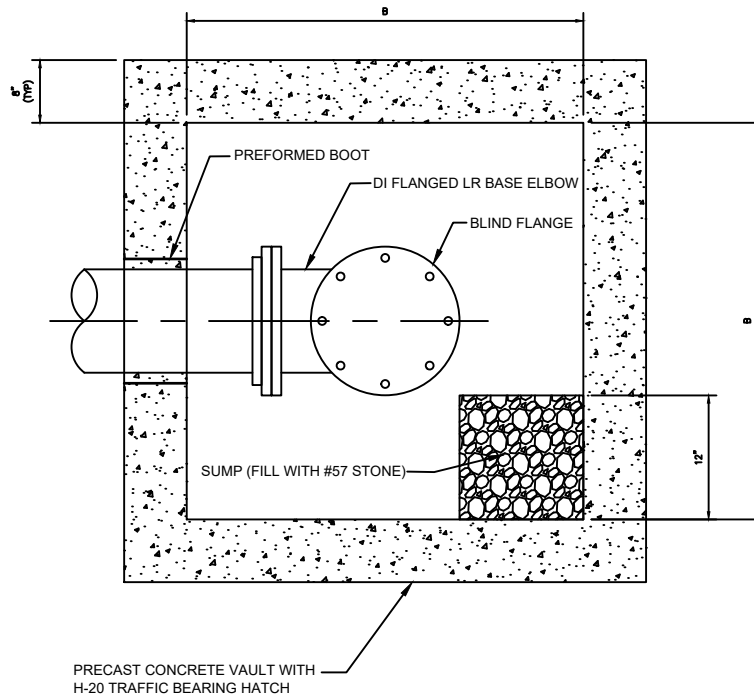

SWABBING LAUNCHING STATION DETAIL FOR NEW FORCE MAIN UP TO 24"

PLATE S-54B

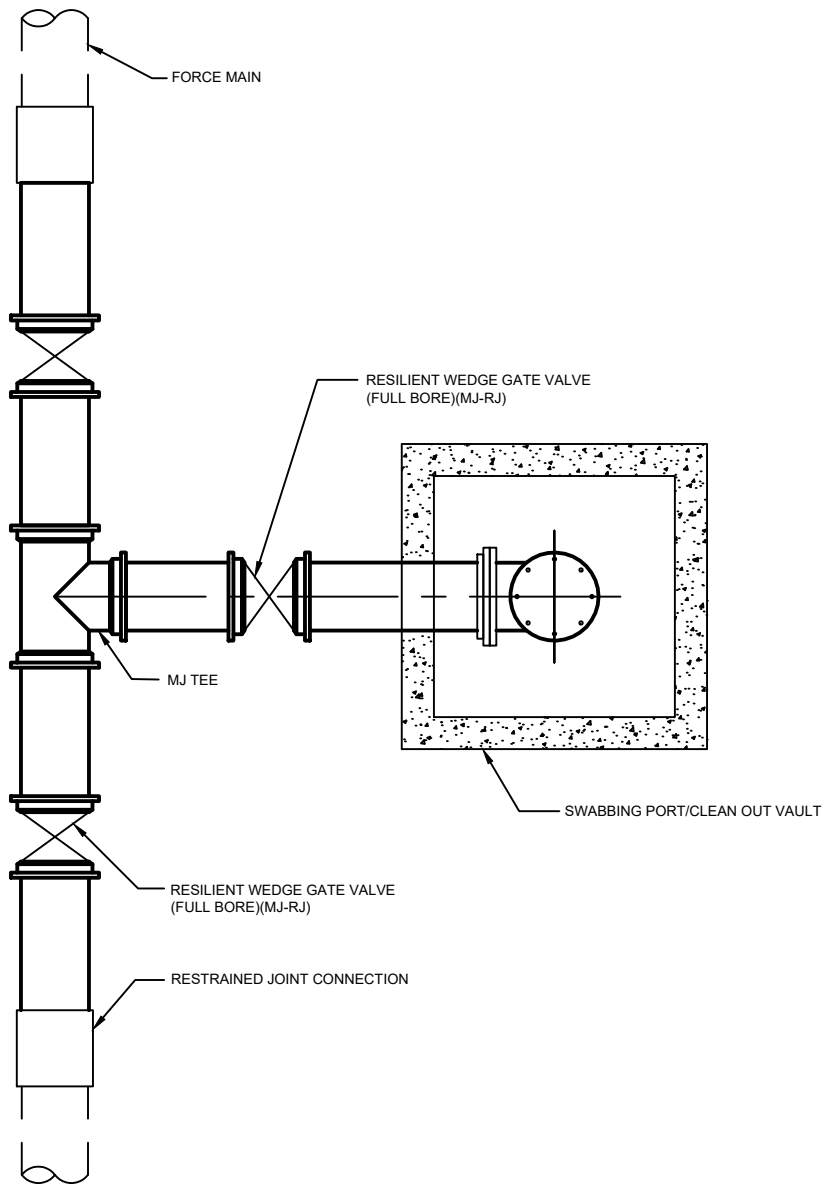

SWABBING LAUNCHING STATION DETAIL FOR FORCE
MAINS UP TO 24" - PLAN
PLATE S-54C

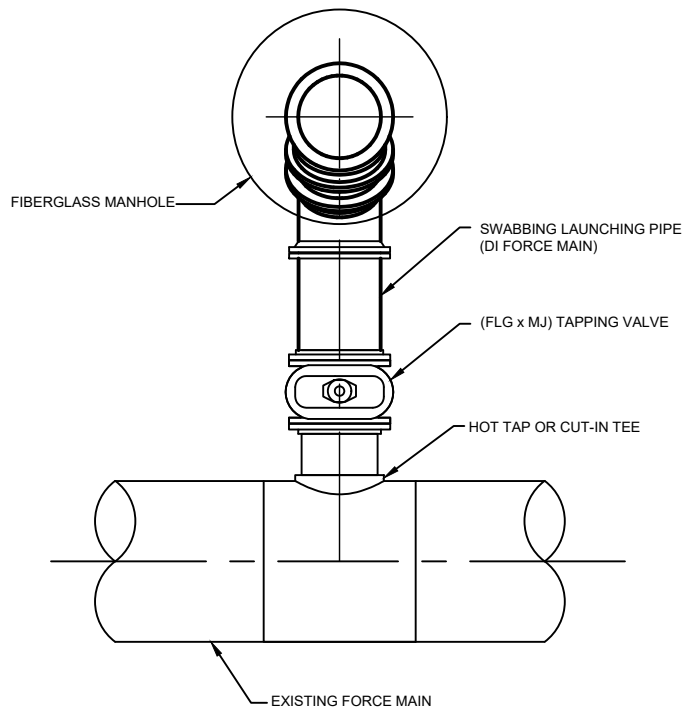

NOTES:

1. FOR HOT TAP CONNECTIONS ON EXISTING FORCE MAINS 10" DIAMETER AND GREATER, DIAMETER OF TAPPING VALVE AND PIG LAUNCHING PIPE SHALL BE ONE NOMINAL SIZE LESS THAN EXISTING FORCE MAIN.

RETROFIT SWABBING LAUNCHING STATION DETAIL FOR FORCE MAINS UP TO 24" - SECTION PLATE S-54D

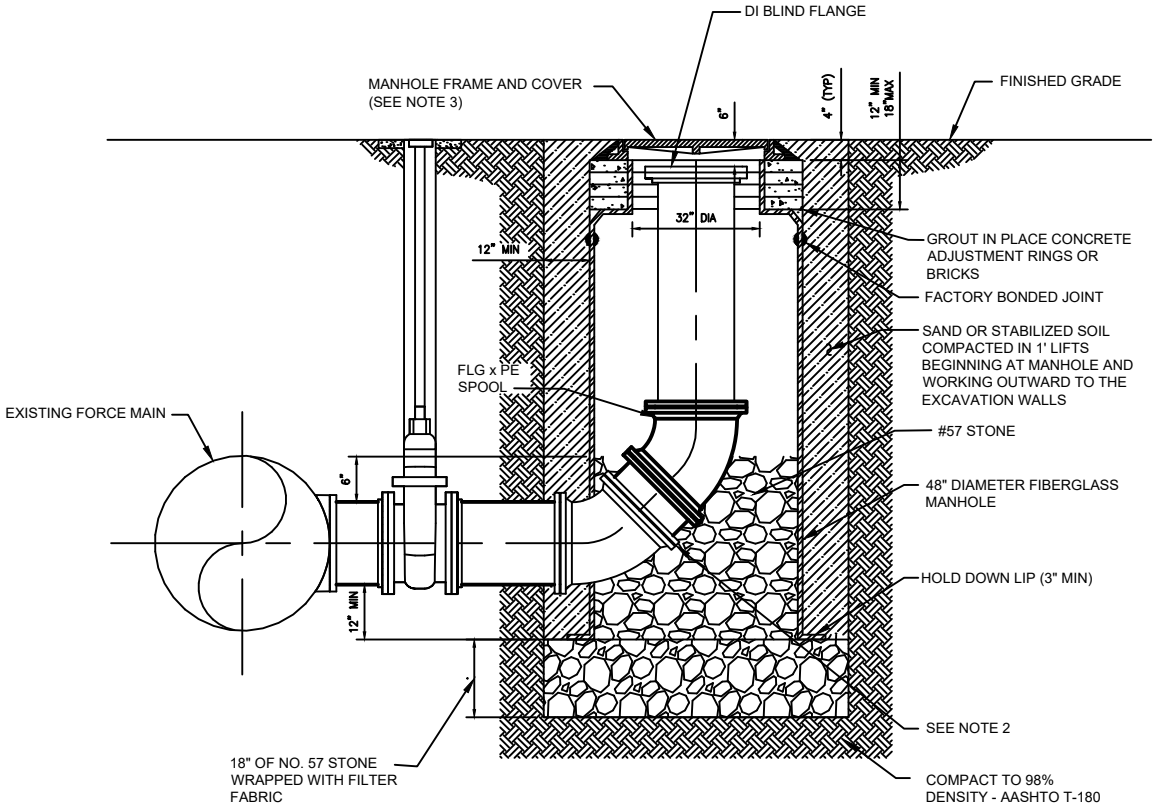

NOTES:

- 1. PROVIDE ALL MATERIALS IN ACCORDANCE TO JEA WATER AND WASTEWATER STANDARD SPECIFICATIONS.
- 2. USE TWO VERTICAL 45 DEGREE MJ BENDS OR LONG RADIUS 90 DEGREE MJ BEND.
- 3. PROVIDE STANDARD JEA FRAME AND COVER.
- 4. RESTRAIN ALL JOINTS.

LOCATE WIRE CONSTRUCTION FOR FORCE MAINS

PLATE S-49

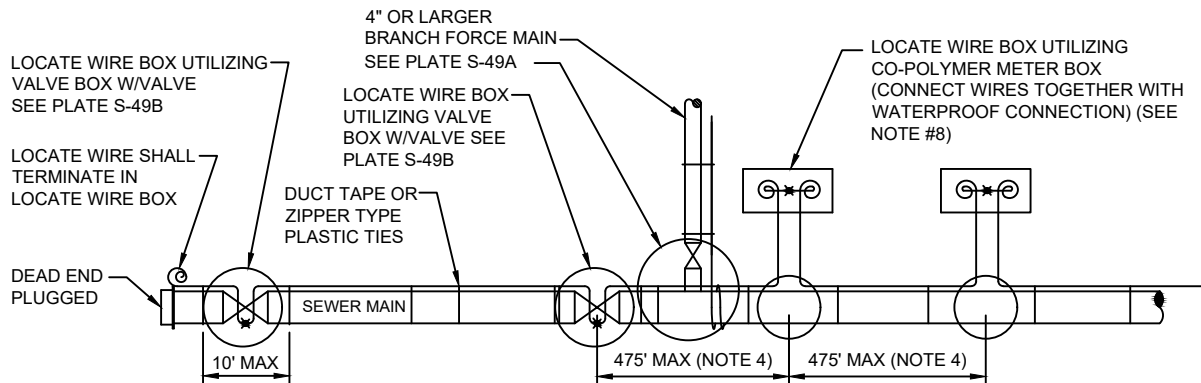

LOCATE WIRE SYSTEM

NOTES:

1. LOCATING WIRE TO BE INSTALLED IN EITHER THE ONE OR ELEVEN O'CLOCK POSITION ON ALL DUCTILE IRON OR PVC (PRESSURE MAINS). LOCATE WIRE SHALL ALSO BE INSTALLED ON ALL (HDPE) POLY MAIN PIPING (1:00 OR 11:00 POSITION, IF POSSIBLE).
2. SECURE LOCATING WIRE TO PVC FORCE MAIN BY USE OF DUCT TAPE OR ZIPPER TYPE PLASTIC TIE STRAPS SPACED AT A MAXIMUM DISTANCE OF TEN (10') AND AT EACH SIDE OF BELL JOINT OR FITTING.
3. THE ENTIRE LOCATING SYSTEM SHALL BE SUBJECTED TO TESTING TO DETERMINE ITS RELIABILITY. WHERE INSTALLED UNDER PAVEMENT AREAS, TESTING SHALL BE DONE PRIOR TO THE PLACEMENT OF PAVEMENT, UNLESS APPROVED OTHERWISE BY JEA.
4. LOCATING WIRE SHALL TERMINATE WITHIN AN ACTIVE VALVE BOX (WITH A VALVE) OR A METER BOX (IF NO VALVE) AT 475' INTERVALS. SEE DETAIL PLATE S-49B. WIRE CONNECTIONS BELOW GROUND (OUTSIDE OF A BOX) SHALL BE AVOIDED.
5. LOCATING WIRE SHALL BE 12 GAUGE COPPER WIRE WITH .03 INCHES (MINIMUM) HDPE INSULATION THICKNESS, 0.141 INCHES (MINIMUM) O.D. RATED BREAK LOAD 250LBS., UF RATED (DIRECT BURIAL), GREEN COLOR. FOR HDD INSTALLATIONS, THE LOCATE WIRE SHALL BE COPPER CODED STEEL AS SPECIFIED IN SPEC. SECTION 750.
6. "⊗" INDICATES THAT THE WIRES ARE CONNECTED TOGETHER WITH WATERPROOF CONNECTION. (SEE DETAIL W-49B)
7. "⊙" INDICATES A WIRE PIG-TAIL (24" LONG)
8. AN "LW" CUT SHALL BE CARVED IN THE CONCRETE CURB AND PAINTED AT ALL LOCATE WIRE BOXES.
9. FOUR LANES OF TRAFFIC (HAVING TWO LANES OF TRAFFIC IN EACH DIRECTION) OR GREATER THE LOCATE WIRE AND VALVE BOX SHALL BE OFF-SET TO THE RIGHT-OF-WAY.

LOCATE WIRE FOR BRANCH MAIN

PLATE S-49A

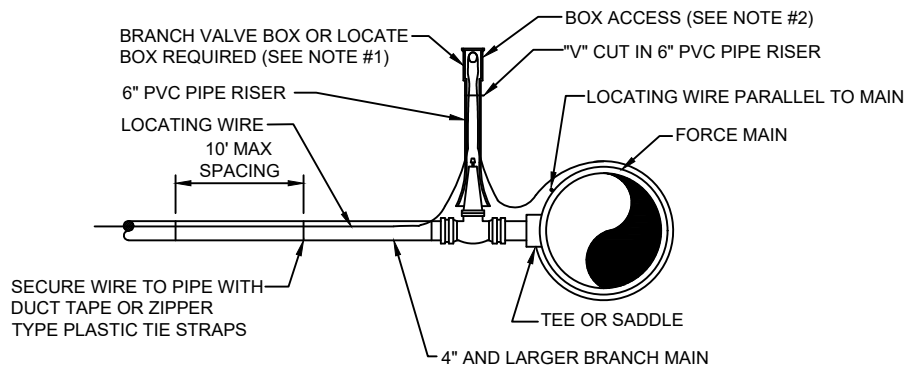

BRANCH FORCE MAIN

(4" AND LARGER SEWER MAIN)

NOTE:

1. NOTE THAT THE BRANCH WIRE IS NOT CONNECTED TO THE MAIN WIRE.
2. LOCATE WIRE SHALL ENTER THE VALVE BOX THROUGH A "V" CUT IN THE 6" PVC RISER PIPE SECTION (SEE S-30).
3. LOCATE WIRE BOX SHALL BE INSTALLED OUTSIDE OF SIDEWALKS, DRIVEWAYS AND PAVEMENT.
4. "Ⓞ" INDICATES A WIRE PIG-TAIL (4' LONG)

LOCATE WIRE BOX

PLATE S-49B

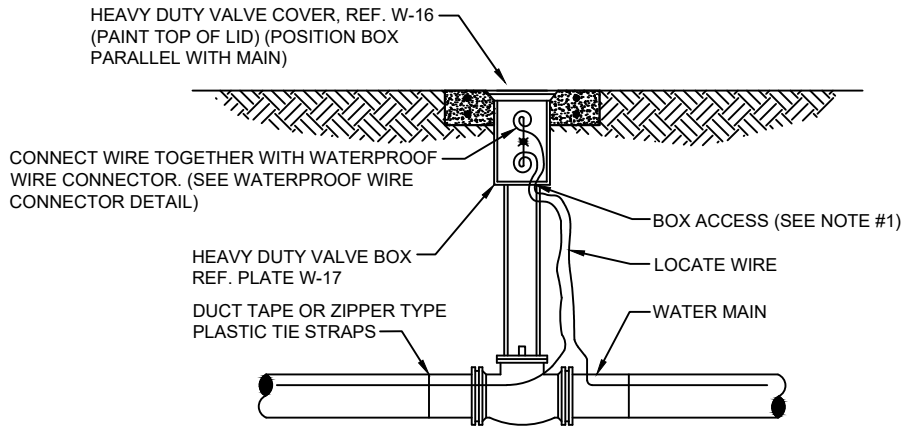

LOCATE WIRE BOX UTILIZING VALVE BOX

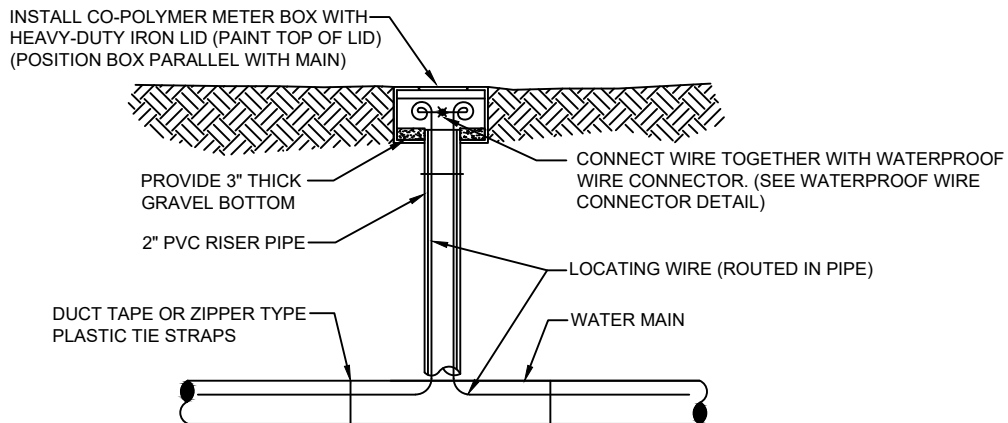

LOCATE WIRE BOX UTILIZING METER BOX

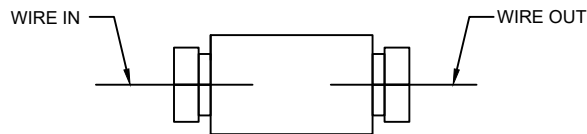

WATERPROOF WIRE CONNECTOR DETAIL

NOTES:

1. LOCATE WIRE SHALL ENTER THE VALVE BOX THROUGH A "V" CUT IN THE 6" PVC RISER PIPE (SEE W-18).
2. LOCATE WIRE SHALL HAVE ENOUGH SLACK TO REACH 4' ABOVE FINAL GRADE AND LOCATE POINTS.
3. LOCATE WIRE CONNECTION SHALL ONLY BE A 2 WAY CONNECTION.

AIR VALVE ASSEMBLY INSIDE MANHOLE

PLATE S-29

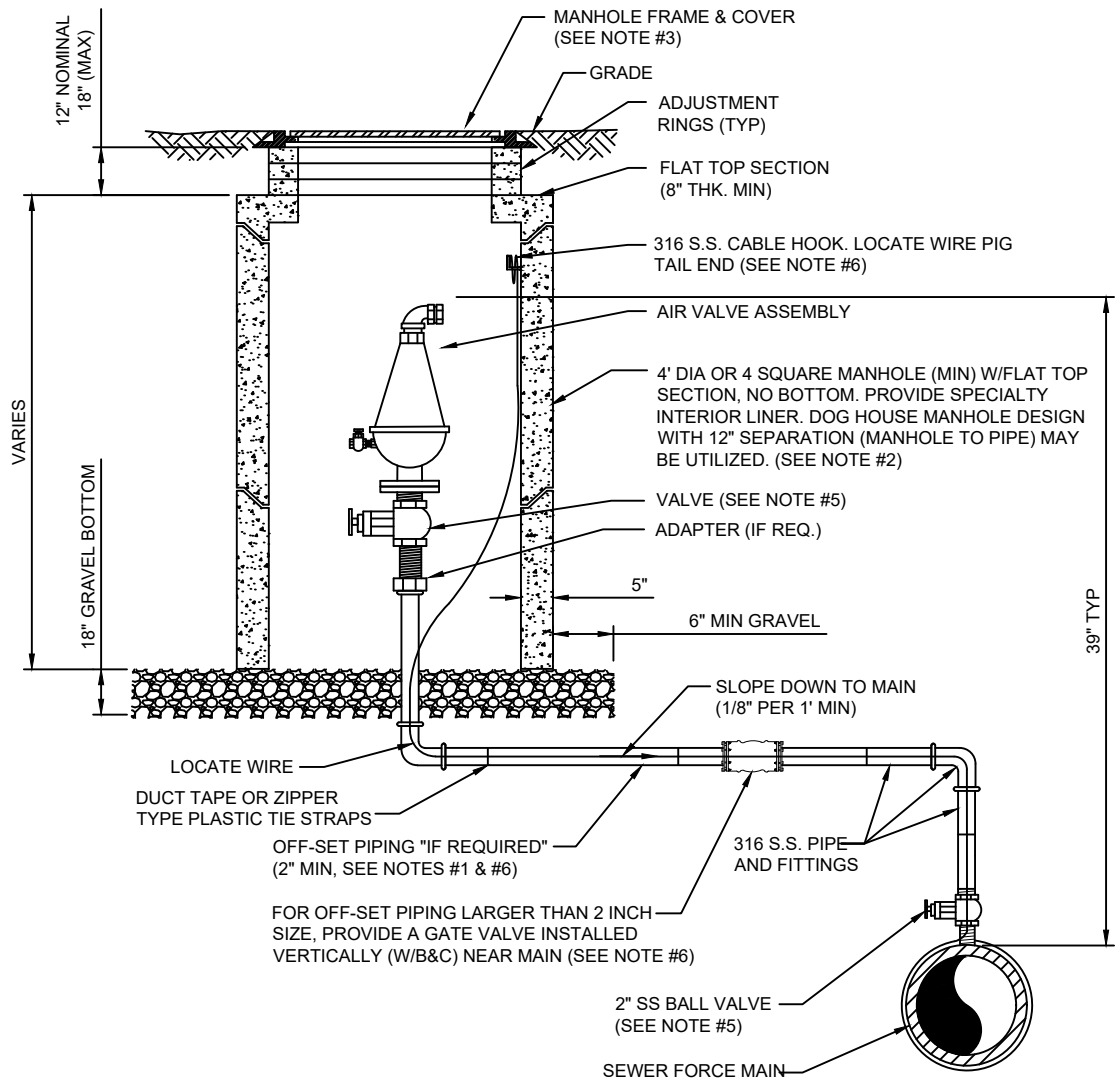

NOTES:

1. THE AIR ASSEMBLY MANHOLE SHALL BE LOCATED OUTSIDE OF THE ROADWAY PAVEMENT AREA (I.E. LOCATED IN NON-TRAFFIC AREAS). IF OFF-SET PIPING IS REQUIRED, THE PIPING SHALL BE 2 INCH MINIMUM, (SAME SIZE AS AIR VALVE INLET). FOR PIPE SIZES 3 INCH AND SMALLER: PIPING SHALL BE 316 STAINLESS STEEL SCH.40, STD GRADE, THREADED. FOR PIPE SIZES 4 INCH AND LARGER: PIPING SHALL BE 316 STAINLESS STEEL SCH. 10 (MIN), WELDED OR PVC DR-18 PIPE AND FITTINGS-RESTRAINED.
2. THE CONCRETE MANHOLE SHALL INCLUDE A POLYURETHANE SPECIALTY LINER (PER SPEC SECTION 446) TO BE INSTALLED ON THE INTERIOR SURFACES INCLUDING THE RISER SECTION TOP AND THE ADJUSTMENT RINGS. A BITUMINOUS WATERPROOFING MATERIAL SHALL BE PROVIDED ON THE OUTSIDE SURFACES OF THE MANHOLE.
3. FRAME AND COVER SHALL BE JEA STANDARD. THE COVER SHALL HAVE NO GASKET TO ALLOW AIR TO EXIT VAULT (REMOVE GASKET IF NECESSARY FROM THE UNDER SIDE OF STANDARD JEA COVER). THE COVER (WHEN FLIPPED OPEN) MUST CLEAR THE AIR VALVE ASSEMBLY AT ALL TIMES OR A SQUARE TOP WITH ALUMINUM DOOR SHALL BE PROVIDED (NON-TRAFFIC LOCATIONS ONLY).
4. FOR PIPE SIZES 3 INCH AND SMALLER, PROVIDE A STAINLESS STEEL BALL VALVE (2" MIN). FOR PIPE SIZES 4 INCH AND LARGER, PROVIDE A FLANGE GATE VALVE (WHEEL OPERATOR) OR PLUG VALVE. (LEVER ARM OPERATOR) SEE SPECIFICATION FOR ADDITIONAL REQUIREMENTS.
5. FOR A 2" AIR VALVE, PROVIDE 2" STAINLESS STEEL BALL VALVE AT THE MAIN. FOR AIR VALVES LARGER THAN 2" SIZE, PROVIDE A TAPPING SLEEVE OR DUCTILE IRON TEE FITTING. ALSO, FOR OFF-SET PIPING LARGER THAN 2 INCH SIZE, PROVIDE A GATE VALVE (INSTALLED VERTICALLY NEAR MAIN). SEE SPECIFICATIONS FOR ADDITIONAL REQUIREMENTS.
6. LOCATE WIRE SHALL HAVE ENOUGH SLACK TO REACH 4' ABOVE FINAL GRADE.

OPTIONAL LOW PROFILE AIR VALVE ASSEMBLY INSIDE MANHOLE

PLATE S-29A

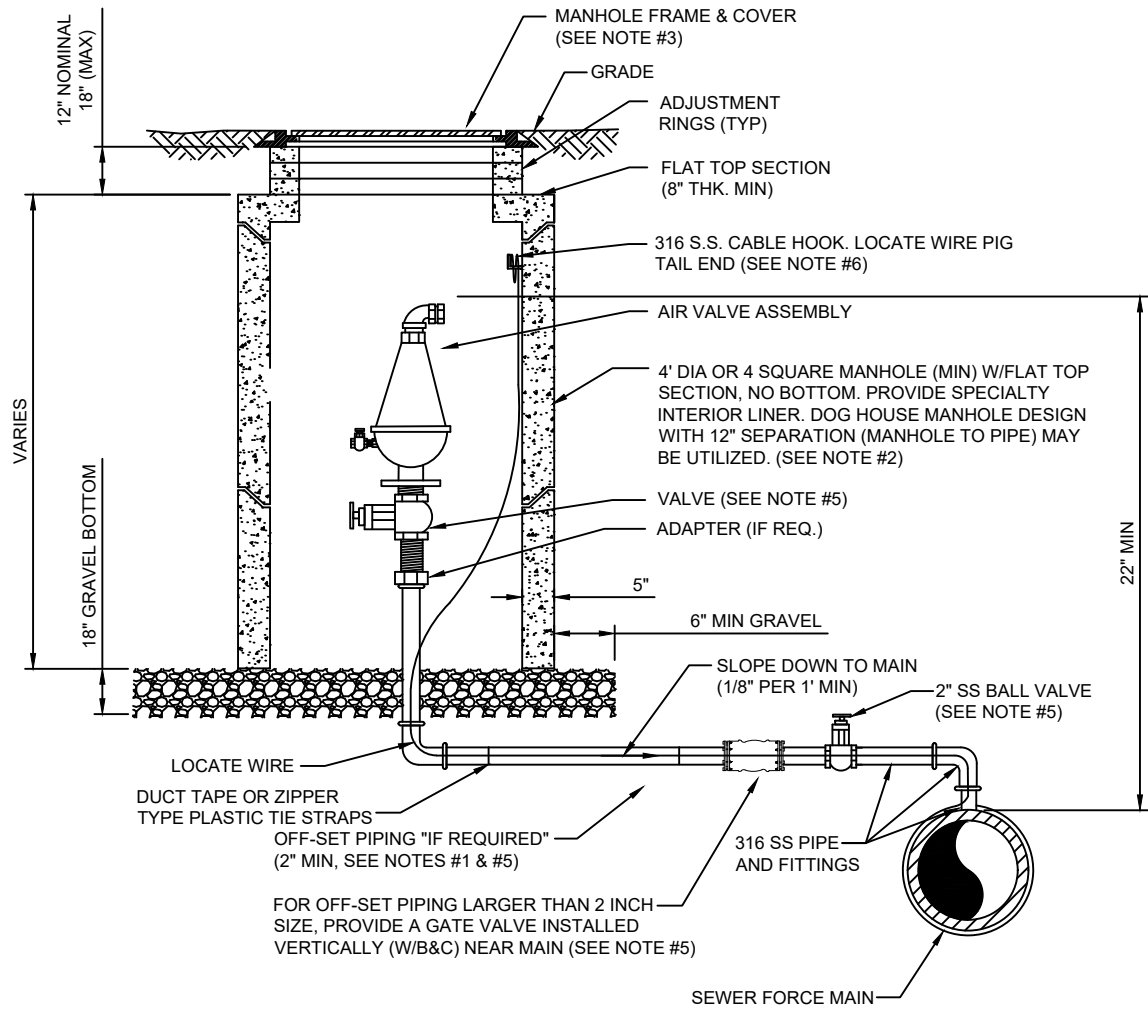

NOTES:

1. THE AIR ASSEMBLY MANHOLE SHALL BE LOCATED OUTSIDE OF THE ROADWAY PAVEMENT AREA (I.E. LOCATED IN NON-TRAFFIC AREAS). IF OFF-SET PIPING IS REQUIRED, THE PIPING SHALL BE 2 INCH MINIMUM, (SAME SIZE AS AIR VALVE INLET). FOR PIPE SIZES 3 INCH AND SMALLER; PIPING SHALL BE 316 STAINLESS STEEL SCH.40, STD GRADE, THREADED. FOR PIPE SIZES 4 INCH AND LARGER; PIPING SHALL BE 316 STAINLESS STEEL SCH. 10 (MIN), WELDED OR PVC DR-18 PIPE AND FITTINGS-RESTRAINED.
2. THE CONCRETE MANHOLE SHALL INCLUDE A POLYURETHANE SPECIALTY LINER (PER SPEC SECTION 446) TO BE INSTALLED ON THE INTERIOR SURFACES INCLUDING THE RISER SECTION TOP AND THE ADJUSTMENT RINGS. A BITUMINOUS WATERPROOFING MATERIAL SHALL BE PROVIDED ON THE OUTSIDE SURFACES OF THE MANHOLE.
3. FRAME AND COVER SHALL BE JEA STANDARD. THE COVER SHALL HAVE NO GASKET TO ALLOW AIR TO EXIT VAULT (REMOVE GASKET IF NECESSARY FROM THE UNDER SIDE OF STANDARD JEA COVER). THE COVER (WHEN FLIPPED OPEN) MUST CLEAR THE AIR VALVE ASSEMBLY AT ALL TIMES OR A SQUARE TOP WITH ALUMINUM DOOR SHALL BE PROVIDED (NON-TRAFFIC LOCATIONS ONLY).
4. FOR PIPE SIZES 3 INCH AND SMALLER, PROVIDE A STAINLESS STEEL BALL VALVE (2" MIN). FOR PIPE SIZES 4 INCH AND LARGER, PROVIDE A FLANGE GATE VALVE (WHEEL OPERATOR) OR PLUG VALVE. (LEVER ARM OPERATOR) SEE SPECIFICATION FOR ADDITIONAL REQUIREMENTS.
5. FOR A 2" AIR VALVE, PROVIDE 2" STAINLESS STEEL BALL VALVE AT THE MAIN. FOR AIR VALVES LARGER THAN 2" SIZE, PROVIDE A TAPPING SLEEVE OR DUCTILE IRON TEE FITTING. ALSO, FOR OFF-SET PIPING LARGER THAN 2 INCH SIZE, PROVIDE A GATE VALVE (INSTALLED VERTICALLY NEAR MAIN). SEE SPECIFICATIONS FOR ADDITIONAL REQUIREMENTS.
6. LOCATE WIRE SHALL HAVE ENOUGH SLACK TO REACH 4' ABOVE FINAL GRADE.

AIR VALVE ASSEMBLY INSIDE MANHOLE IN ROW

PLATE S-29B

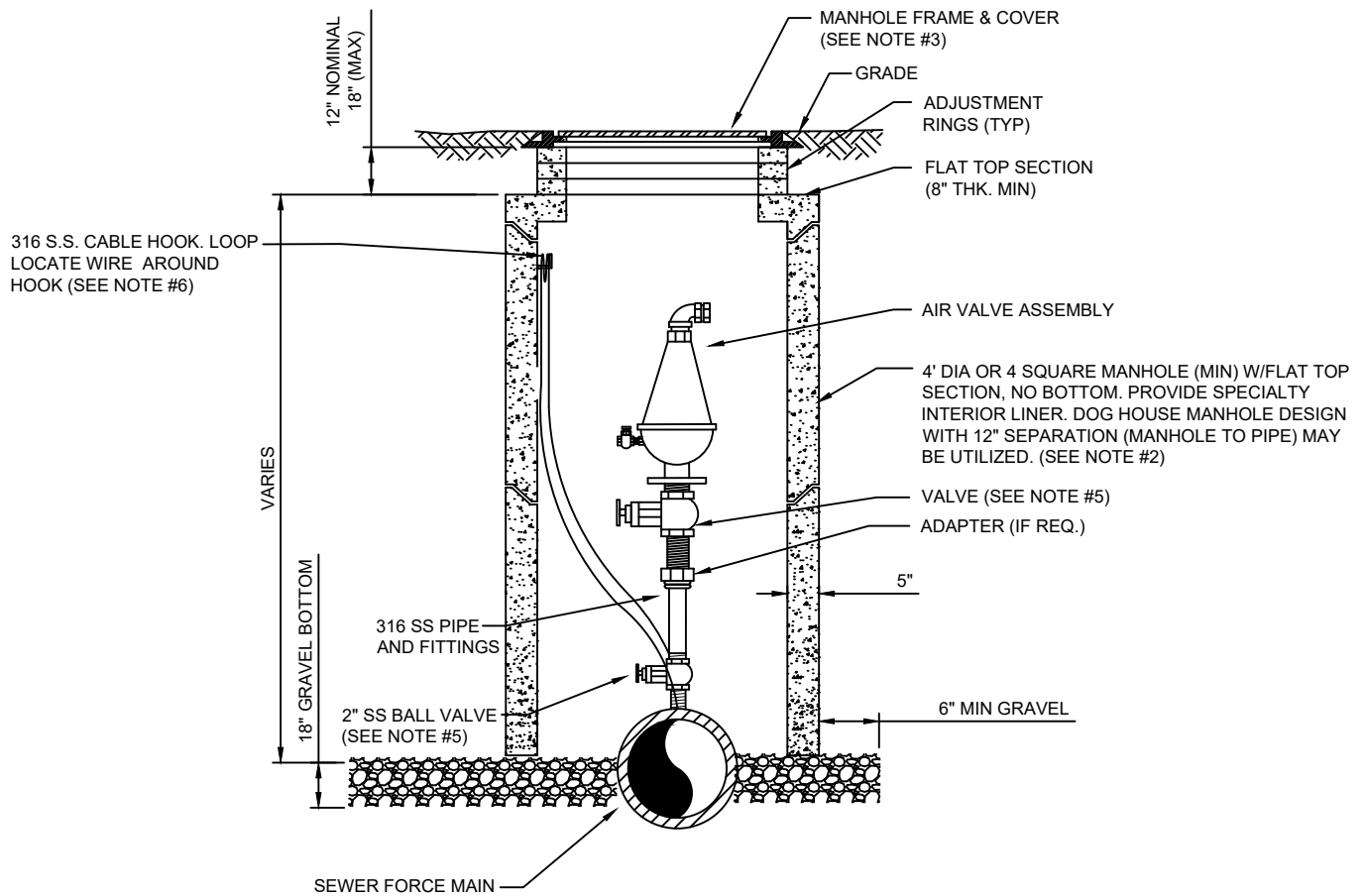

NOTES:

1. THE AIR ASSEMBLY MANHOLE SHALL BE LOCATED OUTSIDE OF THE ROADWAY PAVEMENT AREA (I.E. LOCATED IN NON-TRAFFIC AREAS).
2. THE CONCRETE MANHOLE SHALL INCLUDE A POLYURETHANE SPECIALTY LINER (PER SPEC SECTION 446) TO BE INSTALLED ON THE INTERIOR SURFACES INCLUDING THE RISER SECTION TOP AND THE ADJUSTMENT RINGS. A BITUMINOUS WATERPROOFING MATERIAL SHALL BE PROVIDED ON THE OUTSIDE SURFACES OF THE MANHOLE.
3. FRAME AND COVER SHALL BE JEA STANDARD. THE COVER SHALL HAVE NO GASKET TO ALLOW AIR TO EXIT VAULT (REMOVE GASKET IF NECESSARY FROM THE UNDER SIDE OF STANDARD JEA COVER). THE COVER (WHEN FLIPPED OPEN) MUST CLEAR THE AIR VALVE ASSEMBLY AT ALL TIMES OR A SQUARE TOP WITH ALUMINUM DOOR SHALL BE PROVIDED (NON-TRAFFIC LOCATIONS ONLY).
4. FOR PIPE SIZES 3 INCH AND SMALLER, PROVIDE A STAINLESS STEEL BALL VALVE (2" MIN). FOR PIPE SIZES 4 INCH AND LARGER, PROVIDE A FLANGE GATE VALVE (WHEEL OPERATOR) OR PLUG VALVE. (LEVER ARM OPERATOR) SEE SPECIFICATION FOR ADDITIONAL REQUIREMENTS.
5. FOR A 2" AIR VALVE, PROVIDE 2" STAINLESS STEEL BALL VALVE AT THE MAIN. FOR AIR VALVES LARGER THAN 2" SIZE, PROVIDE A TAPPING SLEEVE OR DUCTILE IRON TEE FITTING. ALSO, FOR OFF-SET PIPING LARGER THAN 2 INCH SIZE, PROVIDE A GATE VALVE (INSTALLED VERTICALLY NEAR MAIN). SEE SPECIFICATIONS FOR ADDITIONAL REQUIREMENTS.
6. LOCATE WIRE SHALL HAVE ENOUGH SLACK TO REACH 4' ABOVE FINAL GRADE.

SEWER VALVE DETAIL

PLATE S-30

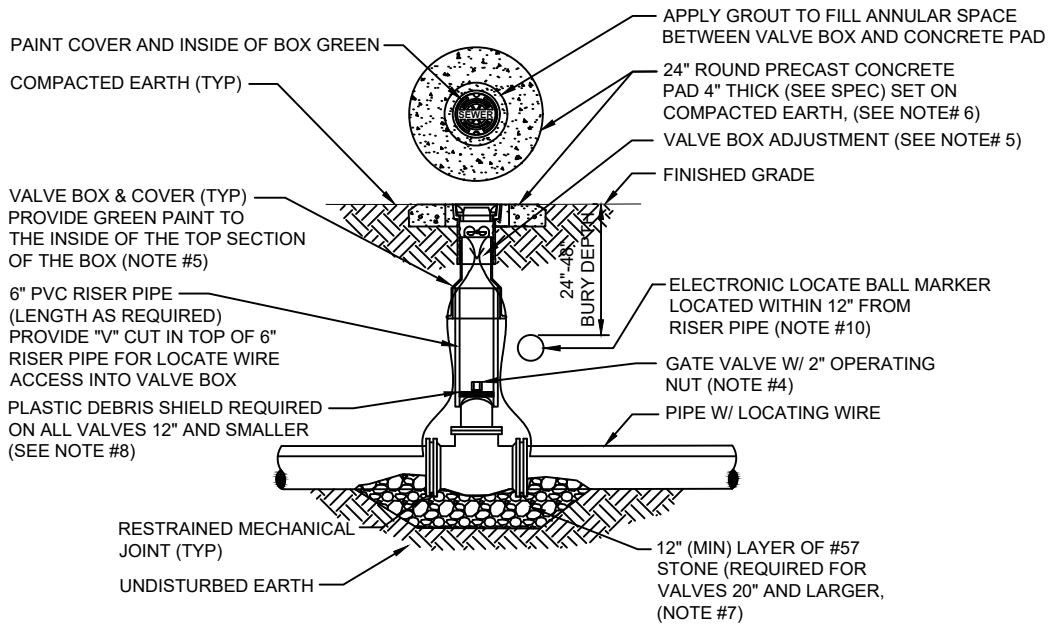

NOTES:

1. FOR UNPAVED LOCATIONS, A PRECAST CONCRETE VALVE PAD SHALL BE PROVIDED AND INSTALLED FLUSH WITH GRADE. CONCRETE PAD IS NOT REQUIRED FOR VALVE LOCATED IN THE ROADWAY, UNLESS SHOWN OR NOTED OTHERWISE.
2. LOCATING WIRE IS REQUIRED ON ALL PRESSURE PIPING (SEE DETAIL S-49).
3. A "V" CUT SHALL BE CARVED IN THE CURB CLOSEST/(ASPHALT IF NO CURB) ADJACENT TO ALL BELOW GRADE VALVES. THE "V" CUT IS TO BE PAINTED GREEN.
4. IN PAVED AREAS, INSTALL VALVE AT A DEPTH TO ALLOW A 12" MIN. DISTANCE BETWEEN THE VALVE COVER PLATE AND THE TOP OF THE VALVE OPERATING NUT. OUTSIDE OF PAVED AREAS (GRASS), INSTALL VALVE AT A DEPTH TO ALLOW A 6" MINIMUM DISTANCE BETWEEN THE VALVE COVER AND THE TOP OF THE VALVE OPERATING NUT. OPERATING NUT/STEM EXTENSION SHALL BE PROVIDED (WHERE APPLICABLE) SO THAT THE OPERATING NUT WILL BE NO MORE THAN 30 INCHES BELOW FINISHED GRADE.
5. FOR NEW CONSTRUCTION, THE VALVE BOX SHALL BE ADJUSTED TO MIDRANGE TO ALLOW FOR FUTURE BOX ADJUSTMENTS. ROUTE LOCATE WIRES THRU A "V" CUT IN THE TOP OF THE 6" PVC RISER PIPE FOR LOCATE WIRE ACCESS INTO VALVE BOX. THE LOCATE WIRES WITH A 24" LONG PIG-TAIL AT THE TOP SHALL BE CONNECTED TOGETHER WITH A WIRE NUT.
6. BRASS IDENTIFICATION TAG INDICATING "SEWER", VALVE SIZE, DIRECTION AND TURNS TO OPEN & VALVE TYPE. PROVIDE A 1/8" HOLE IN BRASS TAG AND ATTACH TAG (TWIST WIRE AROUND TAG) TO THE END OF THE LOCATE WIRE. TAGS ARE NOT REQUIRED ON VALVES INSTALLED ON FIRE HYDRANT BRANCH LINES.
7. IN LIEU OF PRECAST CONCRETE PAD, A 6" THICK X 24" (ROUND OR SQUARE) POURED CONCRETE PAD W/2 - #4 REBAR AROUND PERIMETER, MAY BE USED.
8. GRAVEL SHALL BE PROVIDED UNDER ALL VALVES 20" AND LARGER. THE MINIMUM VERTICAL LIMIT OF GRAVEL IS 12" UNDER THE VALVE UP TO 1/2 THE OVERALL HEIGHT OF THE VALVE.
9. FOR VALVES 12 INCH AND SMALLER, PROVIDE A WHITE OR BLACK PLASTIC DEBRIS SHIELD WHICH INSTALLS BELOW THE OPERATING NUT. THIS SHIELD SHALL CENTER THE RISER PIPE BOX OVER THE OPERATING NUT AND MINIMIZE INFILTRATION. SHIELD SHALL BE BY AFC, BOXLOK OR APPROVED EQUAL.
10. ALL VALVES SHALL BE INSTALLED WITH AN ELECTRIC LOCATE MARKER. MARKER SHALL BE 4" DIA. COLOR CODED BALL MARKER (3M-1404XR FOR SEWER).

SEWER SYSTEM VALVE BOX COVER

PLATE S-31

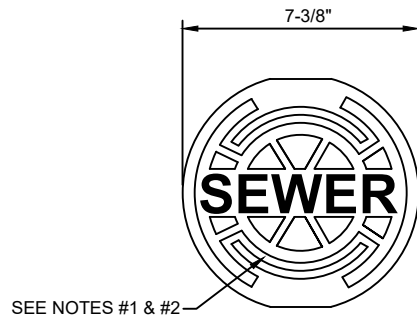

HEAVY DUTY RATING

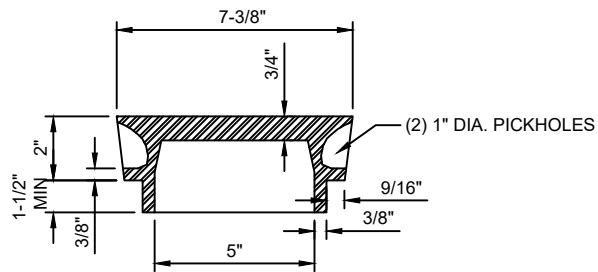

NOTES:

1. PAINT TOP OF THE COVER WITH ENAMEL PAINT (GREEN COLOR).
2. LID WEIGHT: APPROX. 12 LBS.

SEWER SYSTEM VALVE BOX

PLATE S-32

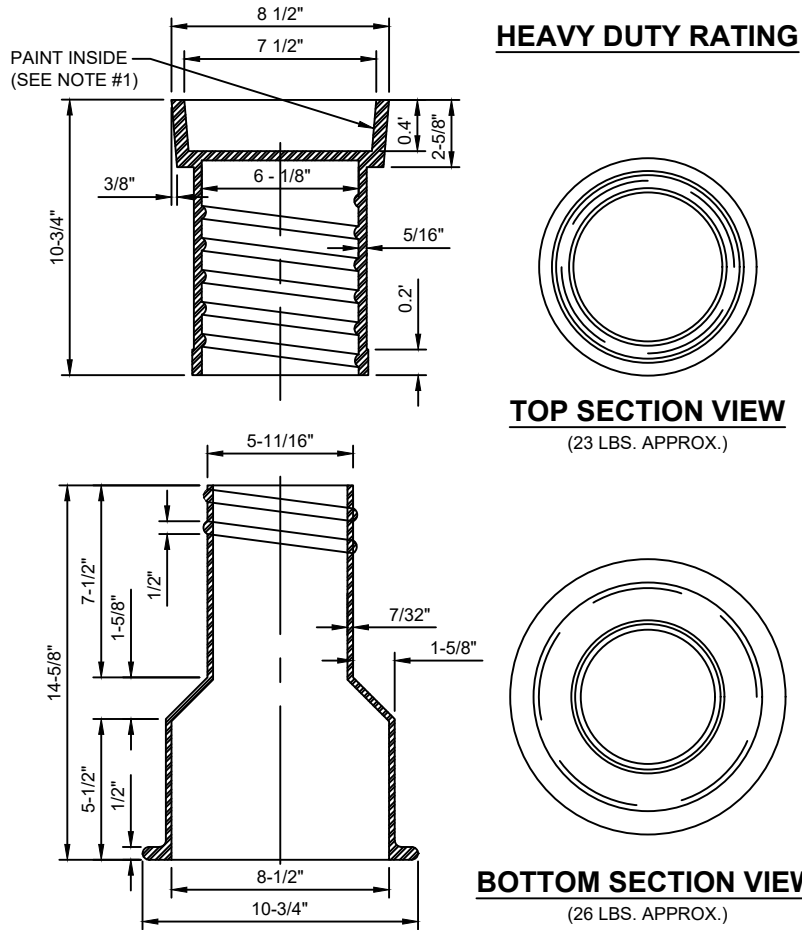

NOTES:

1. PAINT THE INSIDE OF THE TOP SECTION OF THE BOX WITH GREEN COLOR.
2. HEAVY DUTY RATING (TOTAL WEIGHT APPROX. 50 LBS.).
3. REFERENCE SECTION 430, PARAGRAPH VI.2.

SEWER VALVE JACKET ADJUSTMENT AFTER ROADWAY RE-SURFACING

PLATE S-33

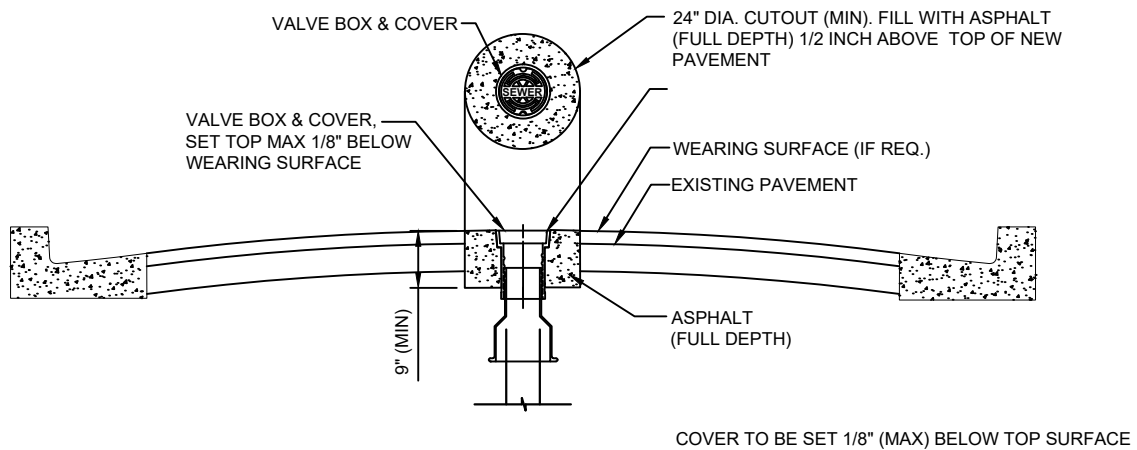

NOTES :

1. PROVIDE FULL DEPTH ASPHALT 1/2 INCH ABOVE TOP OF NEW PAVEMENT LEVEL, TO ALLOW FOR FUTURE ASPHALT MATERIAL COMPACTION. PLACE AND COMPACT ASPHALT IN 2" (MAX) LIFTS.

PREFABRICATED CONCRETE ENCLOSURE

PLATE S-53A

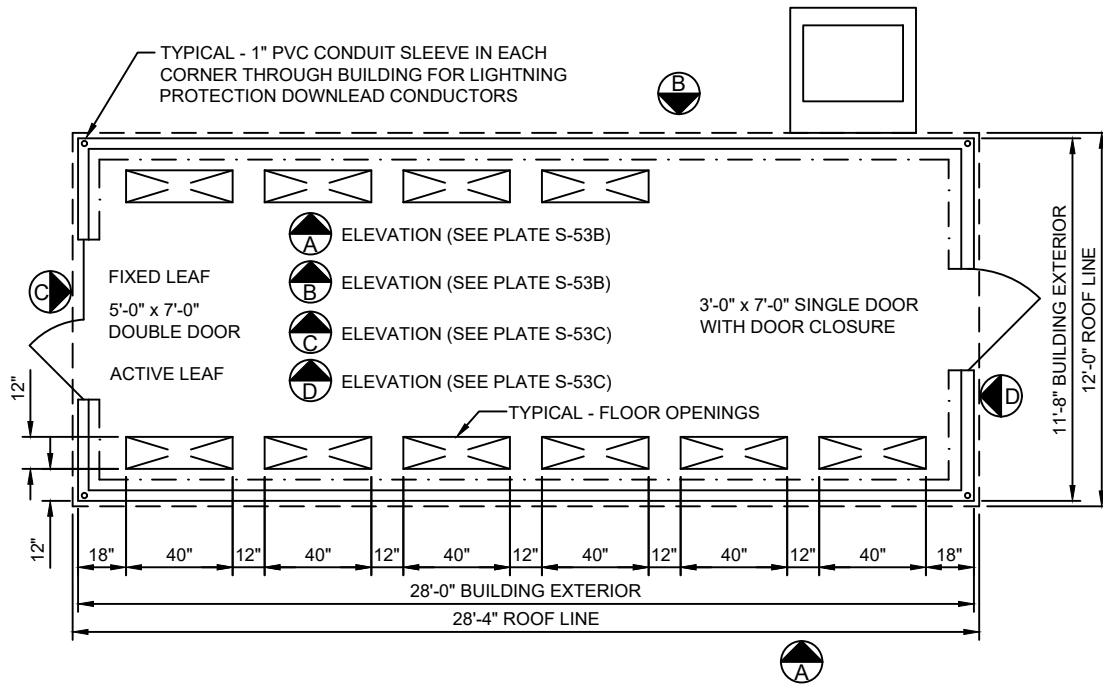

PRE-CAST CONCRETE BUILDING FLOOR PLAN

NOTES:

1. THE ELECTRICAL BUILDING SHALL BE A PRECAST CONCRETE BUILDING AS MANUFACTURED BY OLD CASTLE PRECAST, INC. THE BUILDING DIMENSIONS SHALL BE AS REQUIRED TO ACCOMMODATE THE EQUIPMENT FURNISHED BUT NO LESS THAN MINIMUMS INDICATED ABOVE.
2. SEE STRUCTURAL DRAWING FOR FOUNDATION DETAILS.
3. INTERIOR AND EXTERIOR COLORS OF ELECTRICAL BUILDING TO BE SPECIFIED BY JEA PROJECT MANAGER
4. BUILDING SHALL BE EQUIPPED WITH 7'-0" HIGH ALUMINUM DOORS AND DOOR FRAMES, 316 STAINLESS STEEL HARDWARE, AND JEA STANDARD DOOR LOCKSETS AND KEYS.
5. BUILDING INTERIOR SHALL BE SEALED AND PAINT FINISHED. BUILDING FLOOR SHALL BE SLIP RESISTANT GRAY AND WALLS & CEILINGS SHALL BE PAINTED WHITE.
6. BUILDING EXTERIOR SHALL HAVE TWO APPLICATIONS OF THOROSEAL FINISHED WITH ONE EXPOSED OF THOROCCOAT. PAINT.

PRECAST CONCRETE ELECTRICAL BUILDING GENERAL DESCRIPTION AND RATINGS:

STRUCTURAL:	
OUTSIDE DIMENSION:	28'-0" LONG x 11'-8" WIDE x 10'-5"
HIGH FLOOR LOAD RATING:	250 PSF ROOF LOAD RATING: 65 PSF
WIND LOAD RATING:	150 MPH, EXP "C"
BULLET RESISTANCE:	UL752 LEVEL 4
SEISMIC ZONE:	ZONE 4
TIE DOWN KIT:	BRACKETS AND BOLTS. PROVIDED BY MANUFACTURER AS REQUIRED BY WIND LOAD
FINISHES:	
EXTERIOR WALLS:	EXPOSED AGGREGATE
INTERIOR WALLS:	1/8" FRP MOUNTED ON 1/2" PLYWOOD. WHITE PAINT
INSULATION:	MIN R-15 ON WALLS AND R-22 ON CEILING FLOOR: PREPARED, PRIMED AND FINISHED. SLIP RESISTANT GRAY
COLOR ROOFING:	WHITE ELASTOMERIC COATING. SLOPED SO CENTER RIDGE LINE IS AT LEAST ONE INCH ABOVE SIDES
DOORS AND OPENINGS:	
DOORS:	SEE FLOOR PLAN. 1 3/4" THICK ALUMINUM
LOCKS:	JEA STANDARD LOCKSETS, INTERIOR PANIC BARS
HARDWARE:	ALL HARDWARE AND WEATHER STRIP SHALL BE 316 STAINLESS STEEL
DOOR HOOD:	DOOR DRIP CAPS - 2.5" WIDE
FLOOR:	PREPARED, PRIMED AND FINISHED SLIP RESISTANT GRAY COLOR
OPENINGS:	FLOOR AND WALL BLOCK-OUTS PER FLOOR PLAN

PREFABRICATED CONCRETE ENCLOSURE SIDE ELEVATION

PLATE S-53B

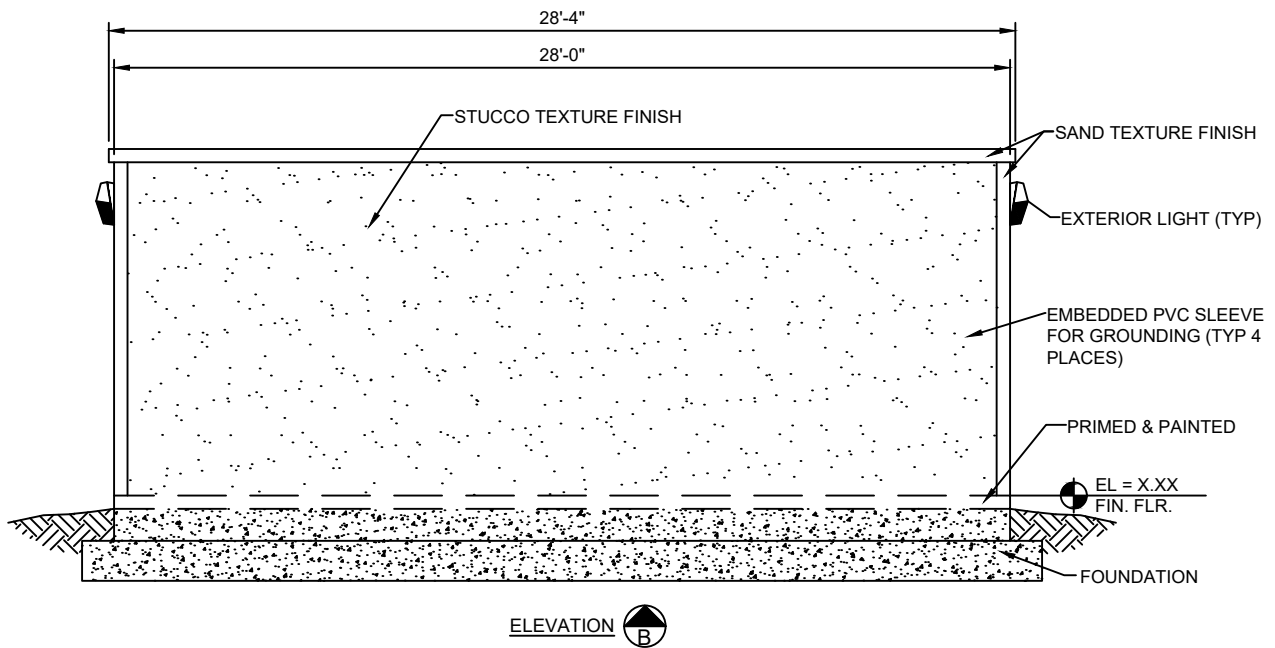
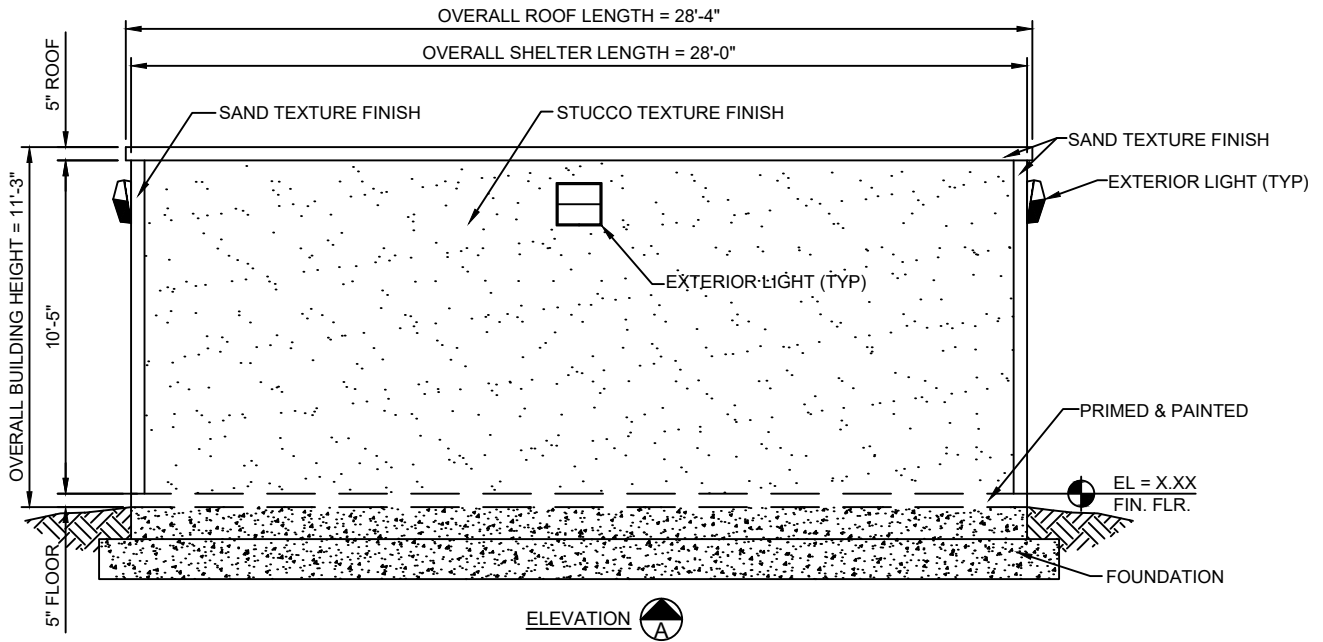

SEE PLATE 53A FOR PLAN AND NOTES

PREFABRICATED CONCRETE ENCLOSURE FRONT & REAR ELEVATION

PLATE S-53C

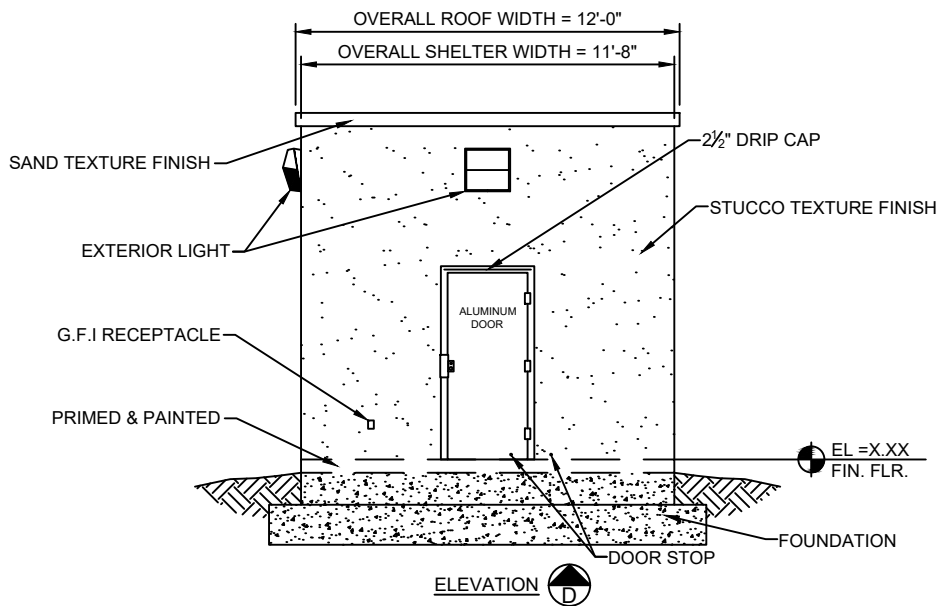
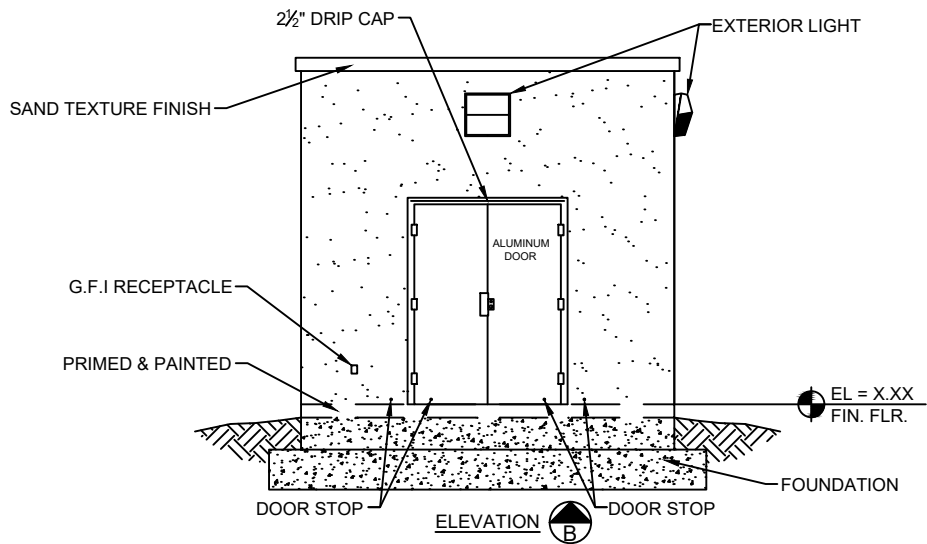

SEE PLATE 53A FOR PLAN AND NOTES

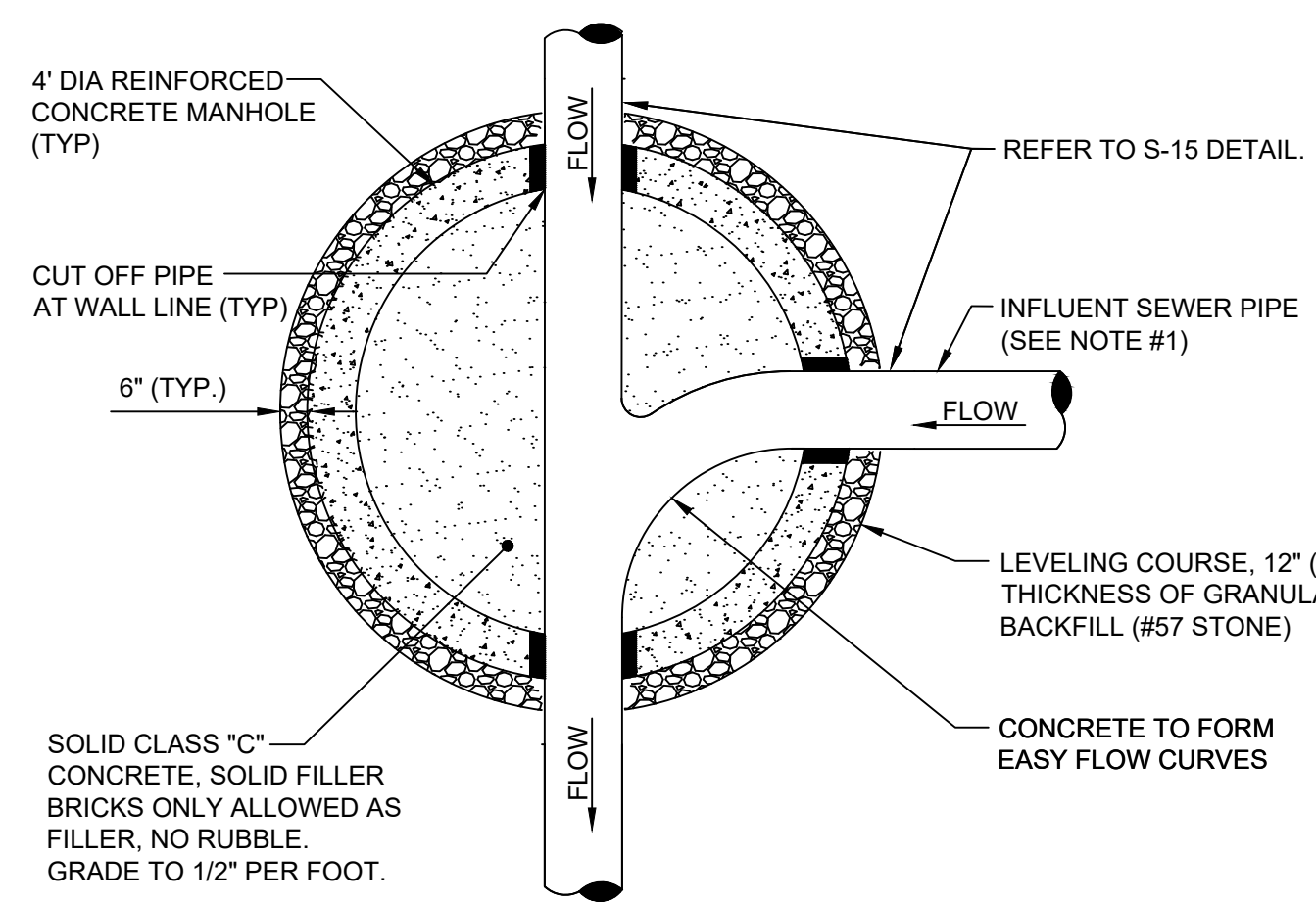

NOTES:

- THE ANGLE BETWEEN ALL INFLUENT FLOW CHANNELS AND EFFLUENT PIPE SHALL BE BETWEEN 90° - 180° UNLESS OTHERWISE APPROVED BY JEA.

PLAN VIEW (S-3)
(FOR SECTION VIEW SEE S-2)

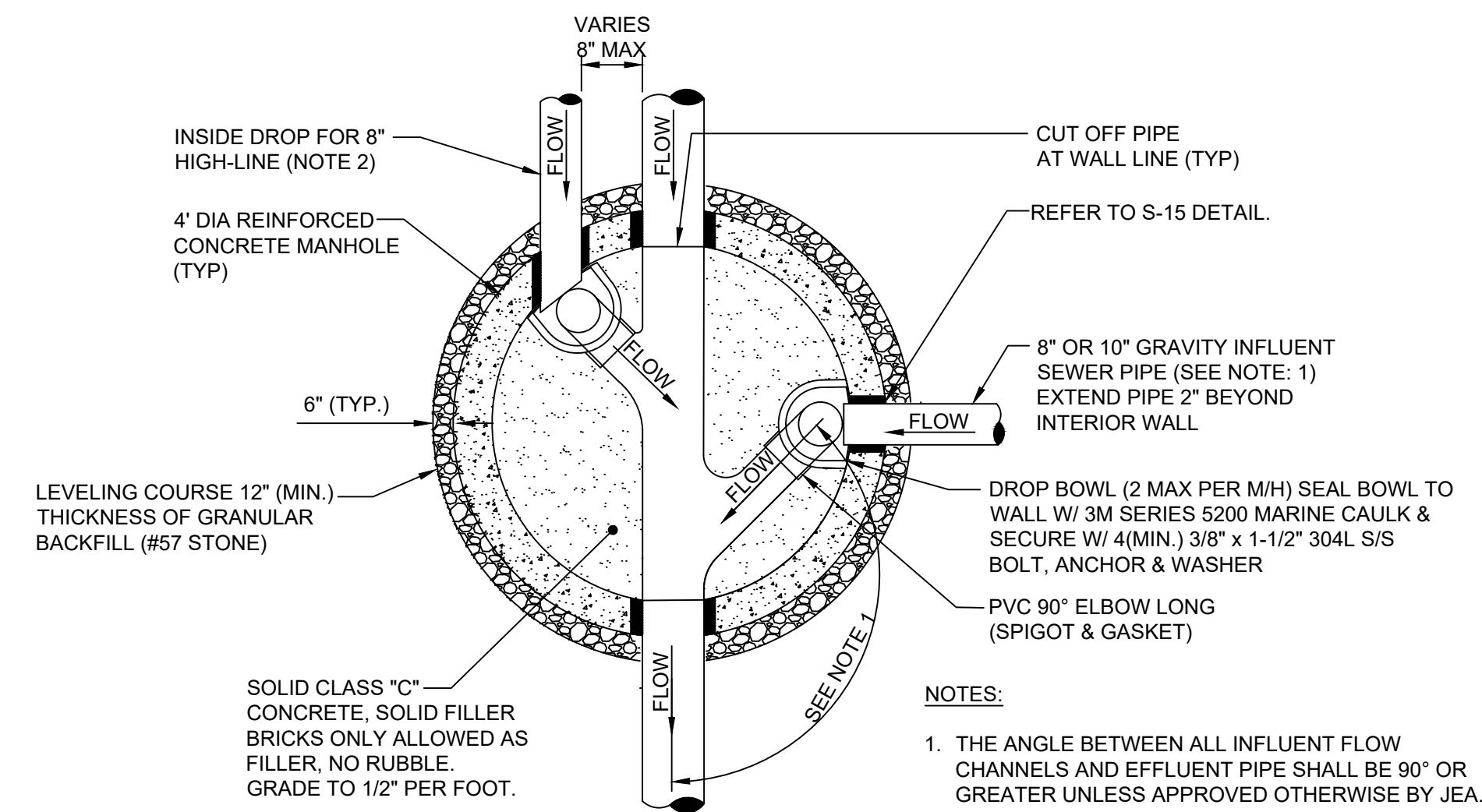

NOTES:

- THE ANGLE BETWEEN ALL INFLUENT FLOW CHANNELS AND EFFLUENT PIPE SHALL BE 90° OR GREATER UNLESS APPROVED OTHERWISE BY JEA.
- THE 8" HIGH-LINE, WHERE UTILIZED, SHALL ENTER THE MANHOLE ON-CENTER OR OFF-CENTER AS SHOWN ABOVE.

PLAN VIEW (S-5)
(FOR SECTION VIEW SEE S-4)

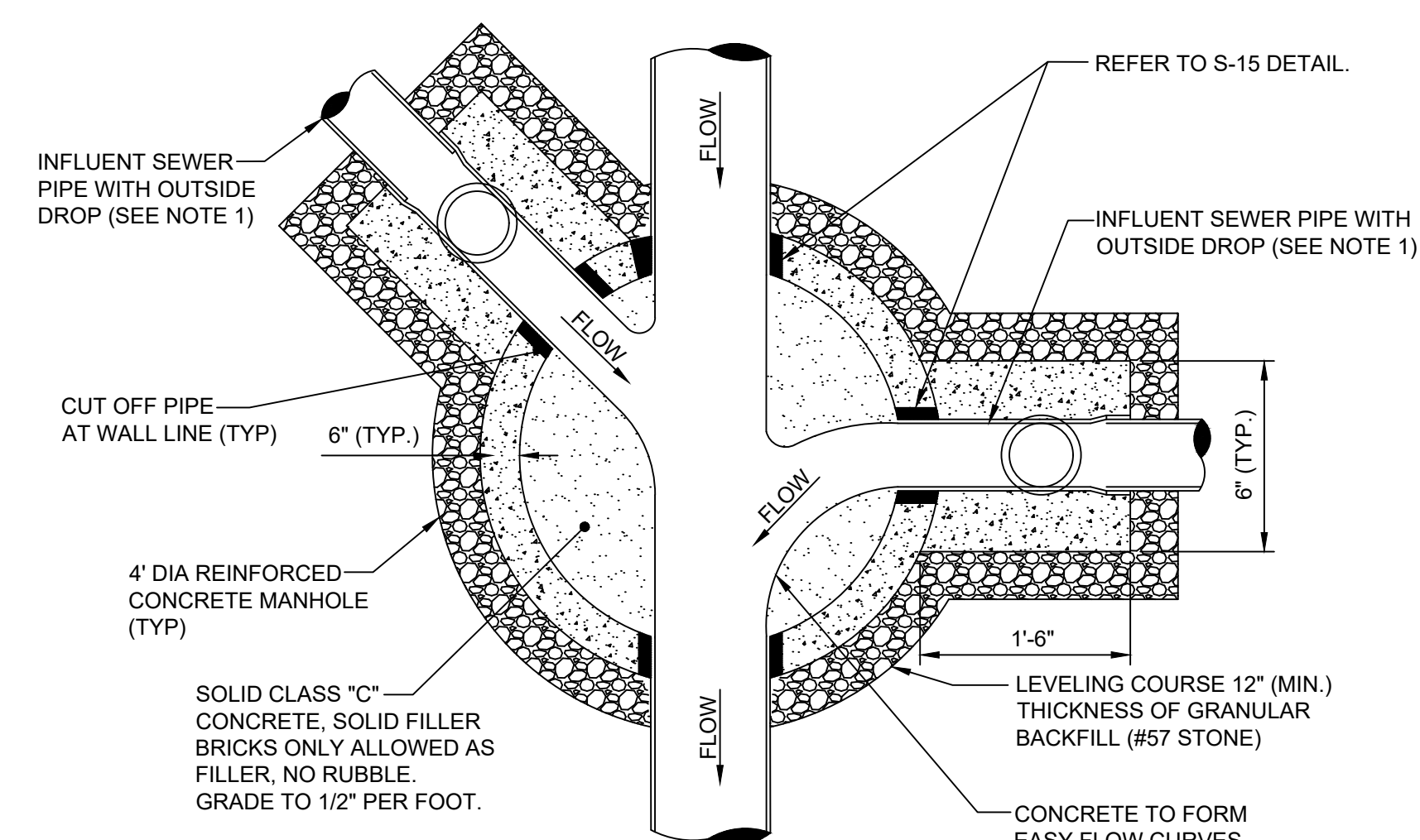

NOTES:

- THE ANGLE BETWEEN ALL INFLUENT FLOW CHANNELS AND EFFLUENT PIPE SHALL BE 90° OR GREATER UNLESS APPROVED OTHERWISE BY JEA.
- THE INTERIOR AND EXTERIOR OF THE MANHOLE AND THE INTERIOR OF THE ADJUSTMENT RINGS SHALL BE GIVEN 2 COATS OF BITUMINOUS WATERPROOFING MATERIAL.
- IF SPECIALTY LINER IS TO BE INSTALLED ON INSIDE OF MANHOLE, THE BITUMINOUS WATERPROOFING MATERIAL SHALL BE OMITTED ON THE INSIDE.
- TYPE "D" MANHOLES SHALL BE USED FOR 12" OR LARGER INFLUENT PIPES W/ 2' OR GREATER INFLUENT DROP.

PLAN VIEW (S-8)
(FOR SECTION VIEW SEE S-7)

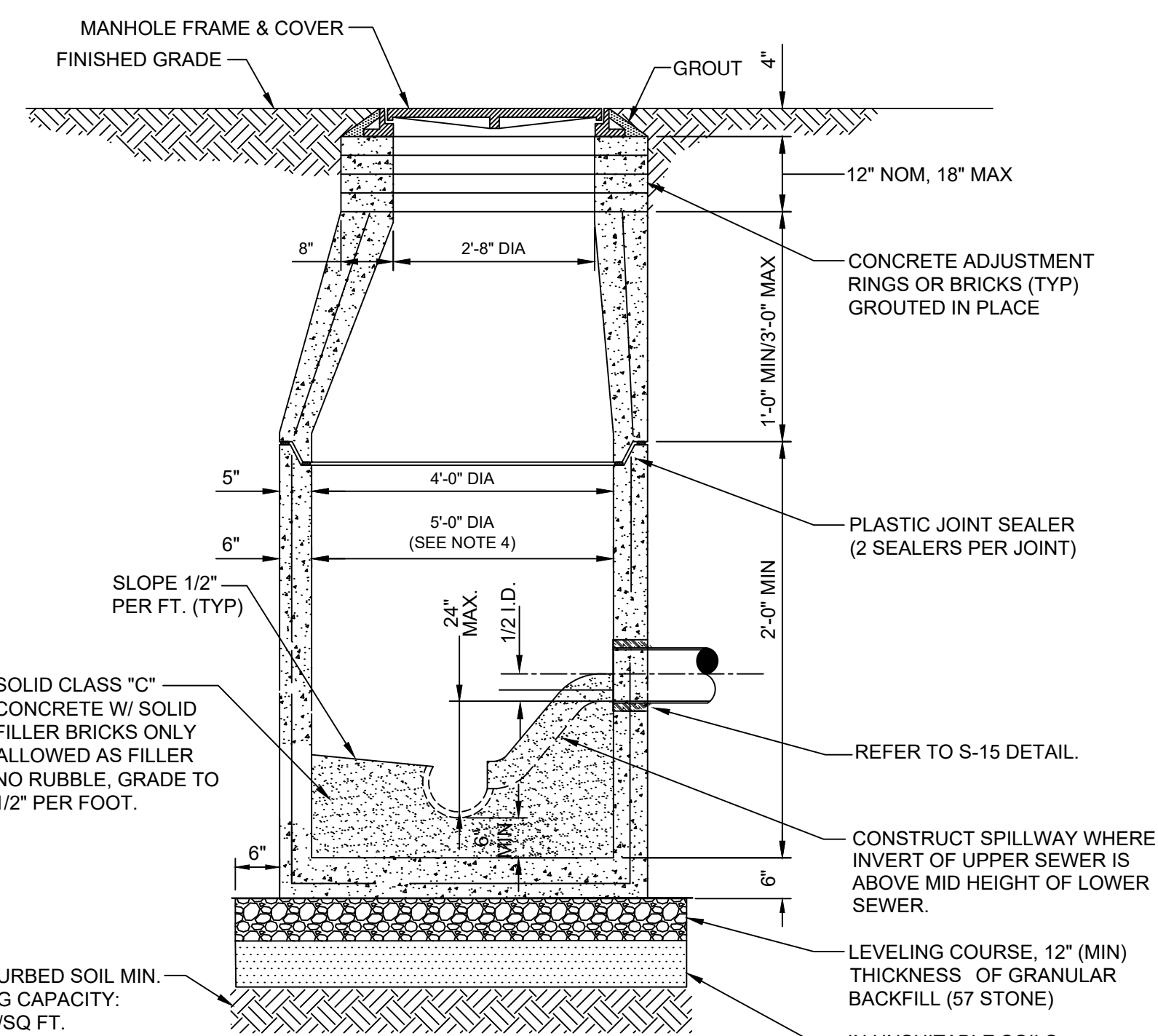

SECTION VIEW (S-2)
(FOR PLAN VIEW SEE S-3)

NOTES:

- PRECAST MANHOLE SECTIONS TO BE MANUFACTURED IN ACCORDANCE WITH THE LATEST EDITIONS OF A.S.T.M. C-478 WITH 4000 LB. CONC., TYPE II CEMENT. ALL LIFTING HOLES AND OUTSIDE INSERTS SHALL BE FILLED WITH NON-SHRINK GROUT AND COATED WITH BITUMINOUS WATERPROOFING MATERIAL.
- THE INTERIOR AND EXTERIOR OF MANHOLE AND ADJUSTING RINGS SHALL BE GIVEN TWO COATS OF BITUMINOUS WATERPROOFING MATERIAL.
- IF SPECIALTY LINER IS TO BE INSTALLED ON INSIDE SURFACE OF MANHOLE, THE BITUMINOUS WATERPROOFING MATERIAL SHALL BE OMITTED ON THE INSIDE.
- JUNCTION MANHOLE (CLOSEST TO WETWELL) SHALL BE 5' DIA WITH SPECIALTY LINER.
- SEAL ALL EXTERIOR JOINTS PER PLATE S-17.
- IN SILTS, CLAY OR HIGHLY ORGANIC SOILS (FINE-GRAINED SOILS INCLUDING SOIL GROUPS ML, CL, OL, MH, CH, OH AND PT) THE SOILS SHALL BE OVER-EXCAVATED AN ADDITIONAL 24" (AT A MIN.) AND BACKFILLED WITH AASHTO CLASS A-3 SOIL (COMPACTED TO 98%, ASTM D1557) OR OVER-EXCAVATE AN ADDITIONAL 12" (AT A MIN.) AND BACKFILL WITH GRANULAR BACKFILL (57 STONE).

SANITARY SEWER TYPE "A" MANHOLE
8"-21" SEWERS

JANUARY 2025 PLATES S-2, S-3

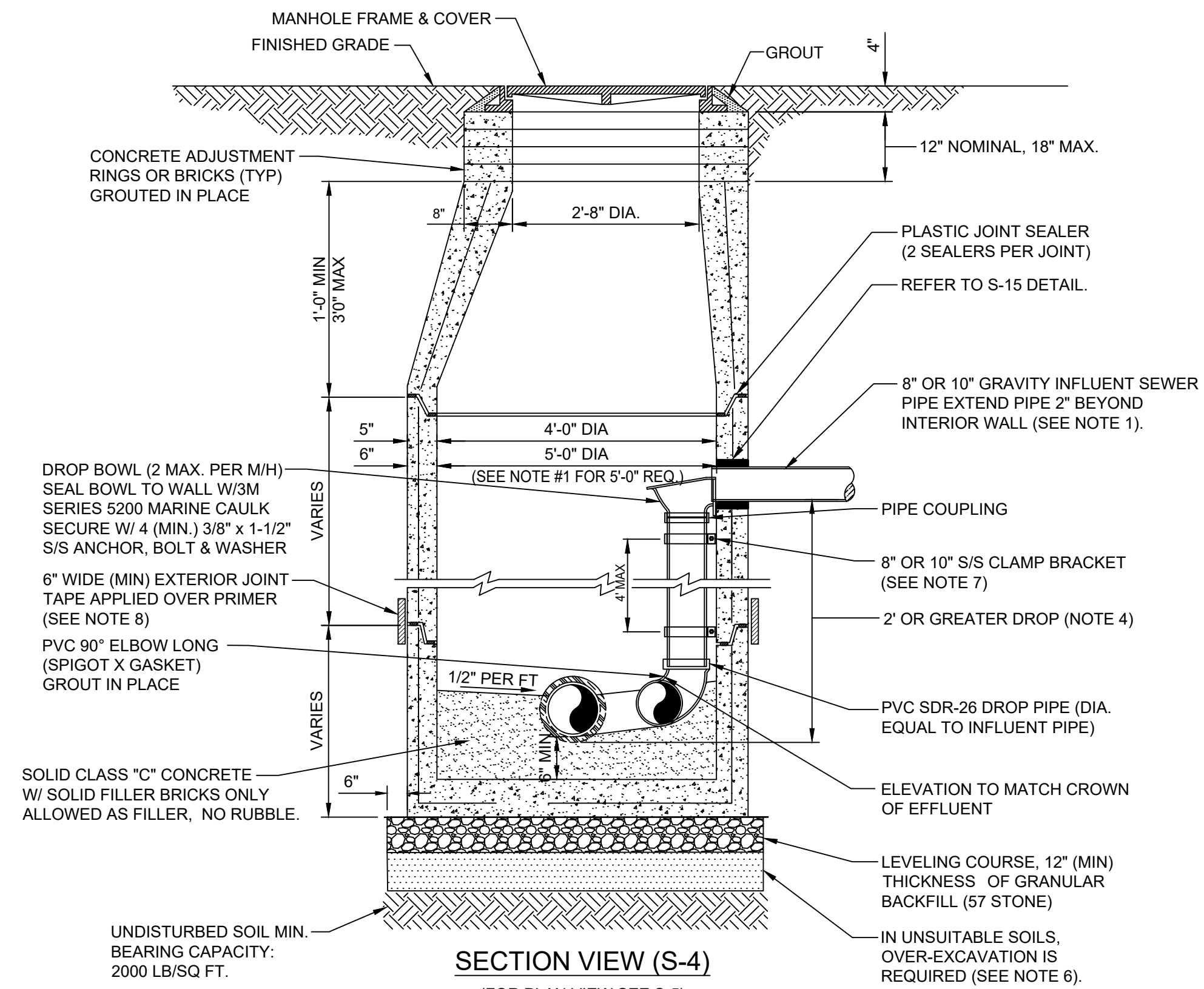

SECTION VIEW (S-4)
(FOR PLAN VIEW SEE S-5)

NOTES:

- THIS ASSEMBLY IS FOR 8" OR 10" GRAVITY INFLUENT LINES ONLY. NO DROPS ALLOWED FOR FORCE MAINS. MAXIMUM OF 2 INSIDE DROP BOWLS PER MANHOLE. A 5'-0" DIA. MANHOLE (6" THICK WALLS) IS REQUIRED IF TWO INSIDE DROPS ARE CONSTRUCTED WITH ONE OR BOTH BEING 10" SIZE. DROP BOWL BY RELINER OR APPROVED EQUAL REQUIRED. THE INSIDE DROP FOR AN 8" HIGH-LINE SHALL BE CONSTRUCTED SIMILAR TO ABOVE (SEE PLATE S-5).
- PRECAST MANHOLE SECTIONS TO BE MANUFACTURED IN ACCORDANCE WITH THE LATEST EDITIONS OF A.S.T.M. C-478 WITH 4000 LB. CONC., TYPE II CEMENT. ALL LIFTING HOLES AND OUTSIDE INSERTS SHALL BE FILLED WITH NON-SHRINK GROUT AND COATED WITH BITUMINOUS WATERPROOFING MATERIAL.
- THE INTERIOR AND EXTERIOR OF MANHOLE AND THE INTERIOR OF ADJUSTMENT RINGS SHALL BE GIVEN TWO COATS OF BITUMINOUS WATERPROOFING MATERIAL.
- TYPE "B" MANHOLE MUST BE USED FOR 2' OR GREATER INFLUENT PIPE DROPS.
- THE DROP BOWL ASSEMBLY SHALL BE INSTALLED PRIOR TO APPLICATION OF SPECIALTY LINING MATERIAL.
- A TYPE "D" MANHOLE SHALL BE UTILIZED WHEN THREE OR MORE (2' OR GREATER) DROPS ARE INVOLVED OR WHEN INFLUENT PIPES AREA LARGER THAN 10" IN SIZE.
- ADJUSTABLE CLAMPING BRACKET (MIN. 2 PER DROP BOWL ASSY), 1-1/2" WIDE, 11 GA. W/ 3/8" DIA. 18-8 PINCH BOLTS AND NUTS. SECURE TO MH WALL WITH (2) 3/8" X 1" BOLT, ANCHOR & WASHER PER BRACKET ASSY. ALL 304 OR 316 STAINLESS STEEL MATERIALS.
- SEAL ALL EXTERIOR JOINTS PER PLATE S-17.
- IN SILTS, CLAY OR HIGHLY ORGANIC SOILS (FINE-GRAINED SOILS INCLUDING SOIL GROUPS ML, CL, OL, MH, CH, OH AND PT) THE SOILS SHALL BE OVER-EXCAVATED AN ADDITIONAL 24" (AT A MIN.) AND BACKFILLED WITH AASHTO CLASS A-3 SOIL (COMPACTED TO 98%, ASTM D1557) OR OVER-EXCAVATE AN ADDITIONAL 12" (AT A MIN.) AND BACKFILL WITH GRANULAR BACKFILL (57 STONE).

SANITARY SEWER TYPE "B" MANHOLE
8"-10" SEWERS

JANUARY 2025 PLATES S-4, S-5

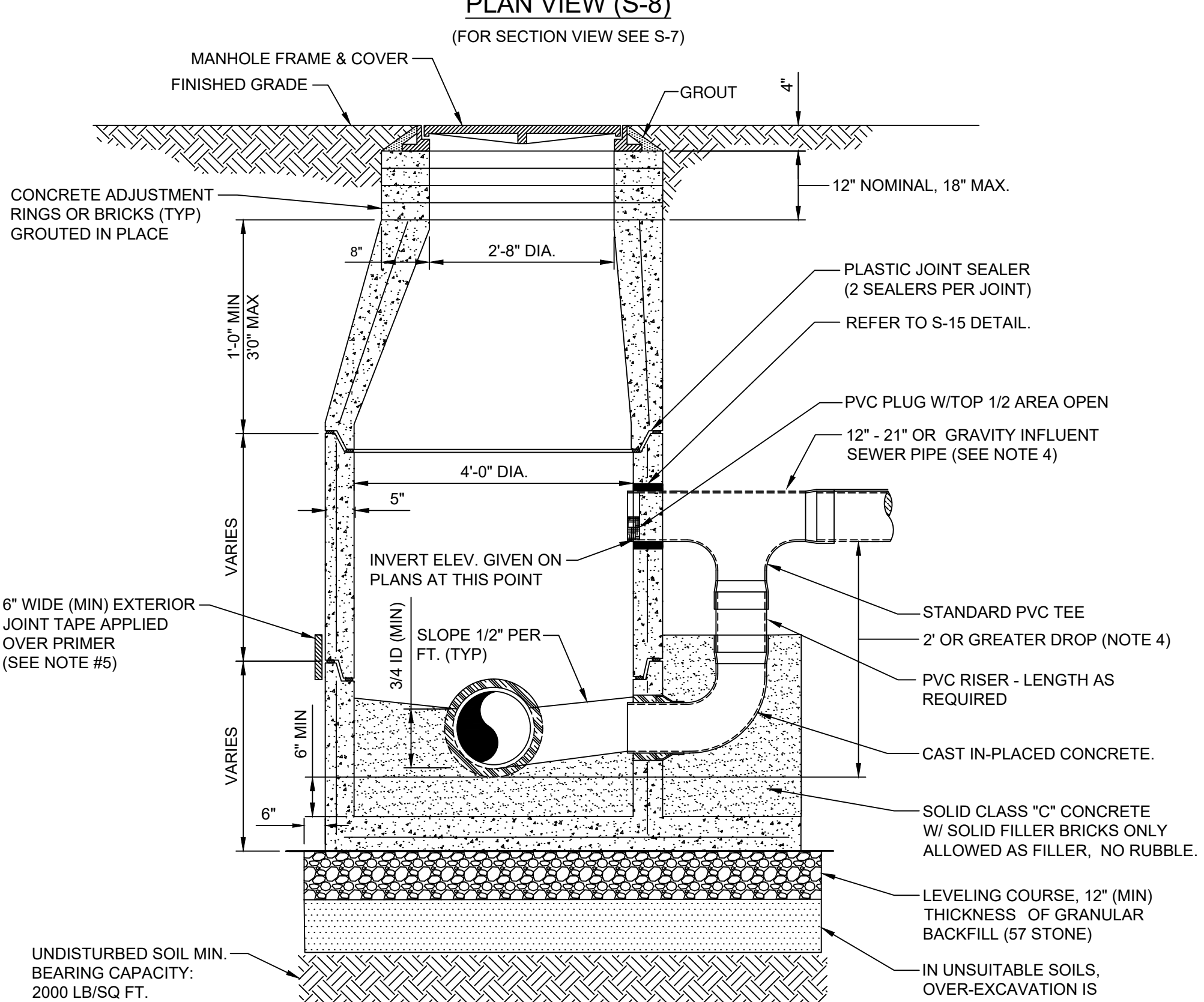

SECTION VIEW (S-7)
(FOR PLAN VIEW SEE S-8)

NOTES:

- PRECAST MANHOLE SECTIONS TO BE MANUFACTURED IN ACCORDANCE WITH THE LATEST EDITIONS OF A.S.T.M. C-478 WITH 4000 LB. CONC., TYPE II CEMENT. ALL LIFTING HOLES AND OUTSIDE INSERTS SHALL BE FILLED WITH NON-SHRINK GROUT AND COATED WITH BITUMINOUS WATERPROOFING MATERIAL.
- THE INTERIOR AND EXTERIOR OF MANHOLE AND THE INTERIOR OF THE ADJUSTMENT RINGS SHALL BE GIVEN TWO COATS OF BITUMINOUS WATERPROOFING MATERIAL.
- IF SPECIALTY LINER IS TO BE INSTALLED ON INSIDE SURFACE OF MANHOLE, THE BITUMINOUS WATERPROOFING SHALL BE OMITTED ON INSIDE.
- TYPE "D" MANHOLE SHALL BE USED FOR 12" OR LARGER INFLUENT PIPES W/ 2' OR GREATER INFLUENT DROP.
- SEAL ALL EXTERIOR JOINTS PER PLATE S-17.
- IN SILTS, CLAY OR HIGHLY ORGANIC SOILS (FINE-GRAINED SOILS INCLUDING SOIL GROUPS ML, CL, OL, MH, CH, OH AND PT) THE SOILS SHALL BE OVER-EXCAVATED AN ADDITIONAL 24" (AT A MIN.) AND BACKFILLED WITH AASHTO CLASS A-3 SOIL (COMPACTED TO 98%, ASTM D1557) OR OVER-EXCAVATE AN ADDITIONAL 12" (AT A MIN.) AND BACKFILL WITH GRANULAR BACKFILL (57 STONE).

SANITARY SEWER TYPE "D" MANHOLE
12"-21" SEWERS

JANUARY 2025 PLATES S-7, S-8

NO. SHEETS		PROJ. NO.		DESIGN ENGINEER	
1	1				
5	5				
SHEET NO.		DATE:		FLORIDA REGISTRATION NO.	
5		JANUARY 2025			
DRAWING NO.		SCALE:			
S-STD-1		AS NOTED			

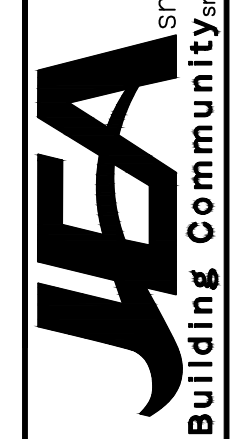

JEA STANDARD
SANITARY SEWER DETAILS

C:\Services\Shared\STANDARD\STANDARD TEAM\2025 Water Wastewater Standards Manual\2025 Volume 2\WASTEWATER DETAILS 2025.dwg
 Current Layout Tab = DETAIL 2
 Thu Feb 13, 2025 - 15:58

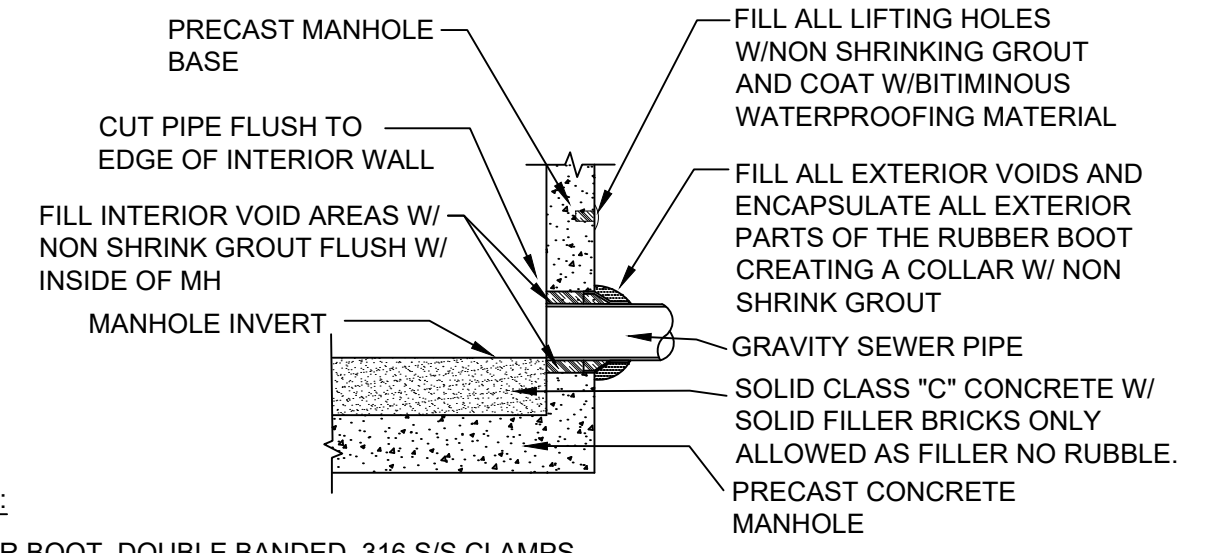

NOTES:
 RUBBER BOOT, DOUBLE BANDED, 316 S/S CLAMPS, MEETING THE ASTM C923 STANDARD. Kor-N-Seal® I EX SERIES CONNECTOR WITH DOUBLE STAINLESS STEEL BANDS OR EQUAL

RUBBER BOOT

(FOR NEW M/H CONSTRUCTION ONLY, MAXIMUM DEPTH 15FT)

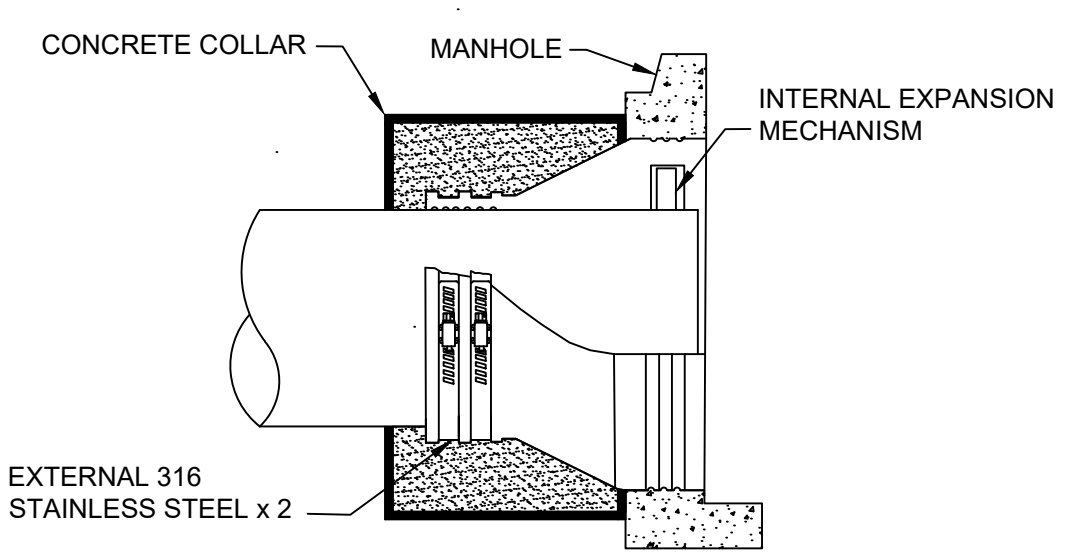

RUBBER BOOT DETAIL

(FOR EXISTING AND NEW M/H CONSTRUCTION)

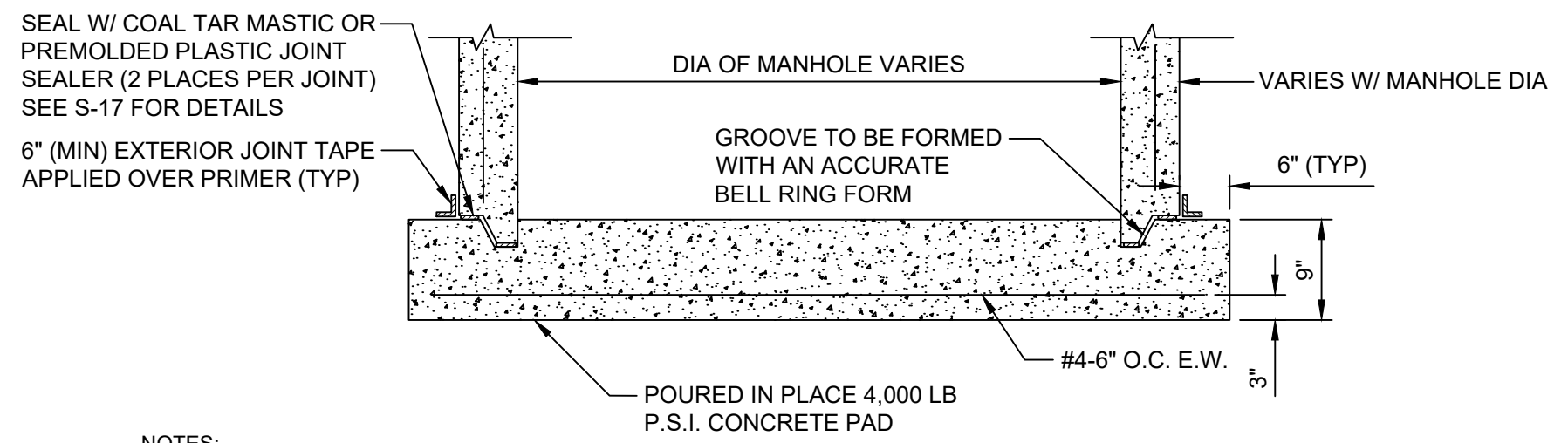

NOTES:
 THE USE OF THE POURED IN PLACE MANHOLE BOTTOM SHALL BE MINIMIZED AND SHALL BE SPECIFICALLY APPROVED BY JEA PRIOR TO CONSTRUCTION.

MANHOLE BOTTOM

MANHOLE BOTTOM DETAILS

JANUARY 2025 PLATE S-15A

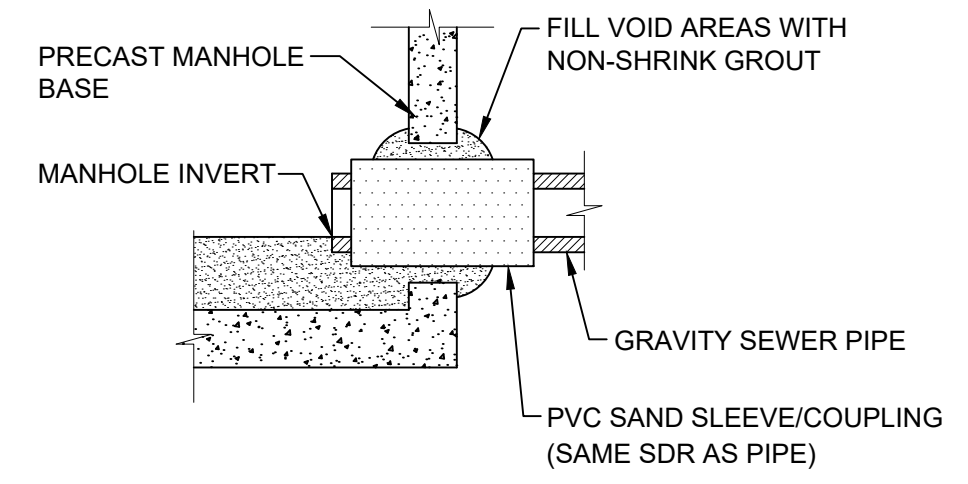

PVC SAND SLEEVE

(FOR EXISTING AND NEW M/H CONSTRUCTION)

CONCRETE AND POLYMER MANHOLE PIPE CONNECTION DETAILS

JANUARY 2025 PLATE S-15

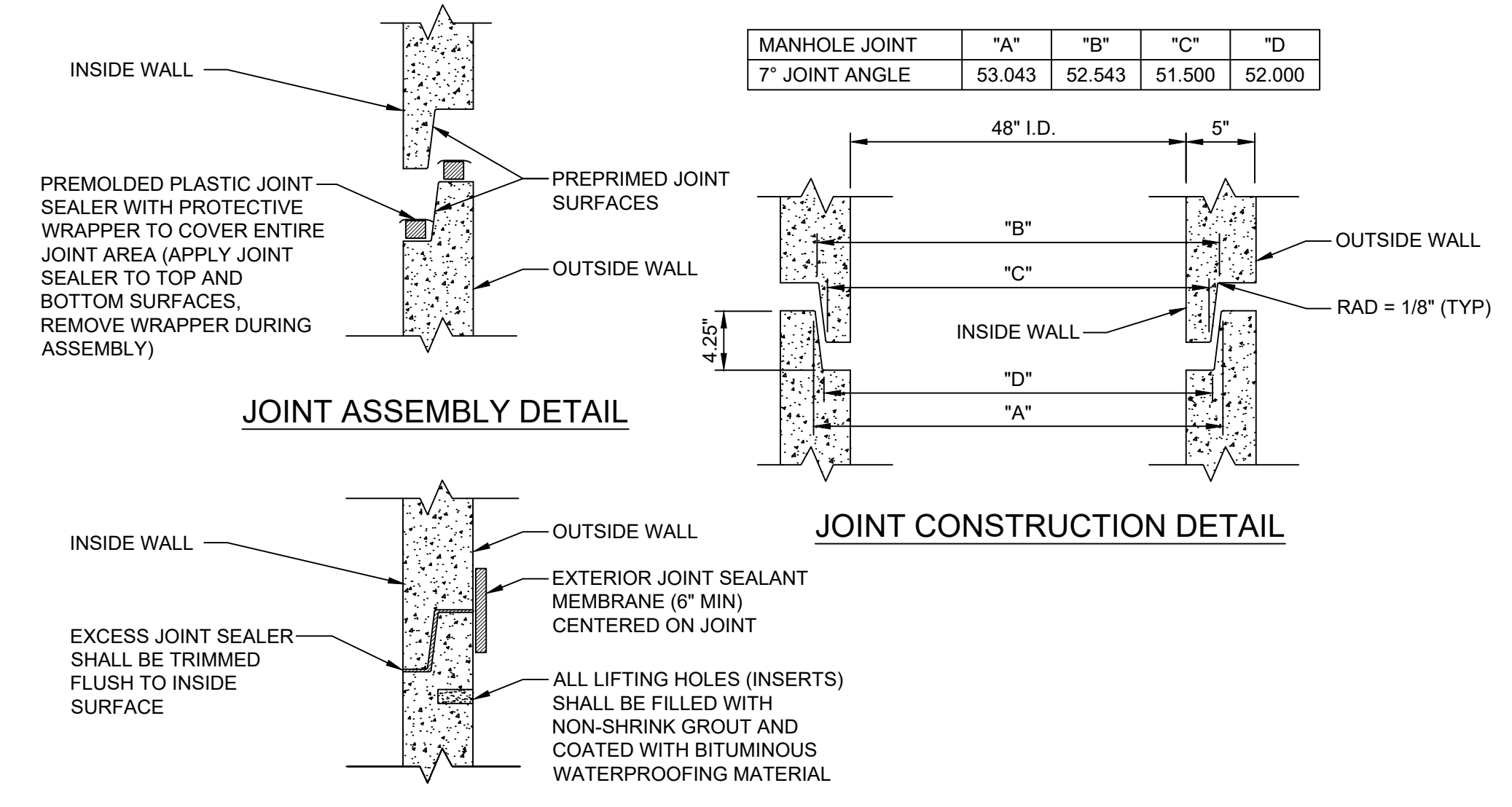

MANHOLE JOINT 7" JOINT ANGLE	"A"	"B"	"C"	"D"
	53.043	52.543	51.500	52.000

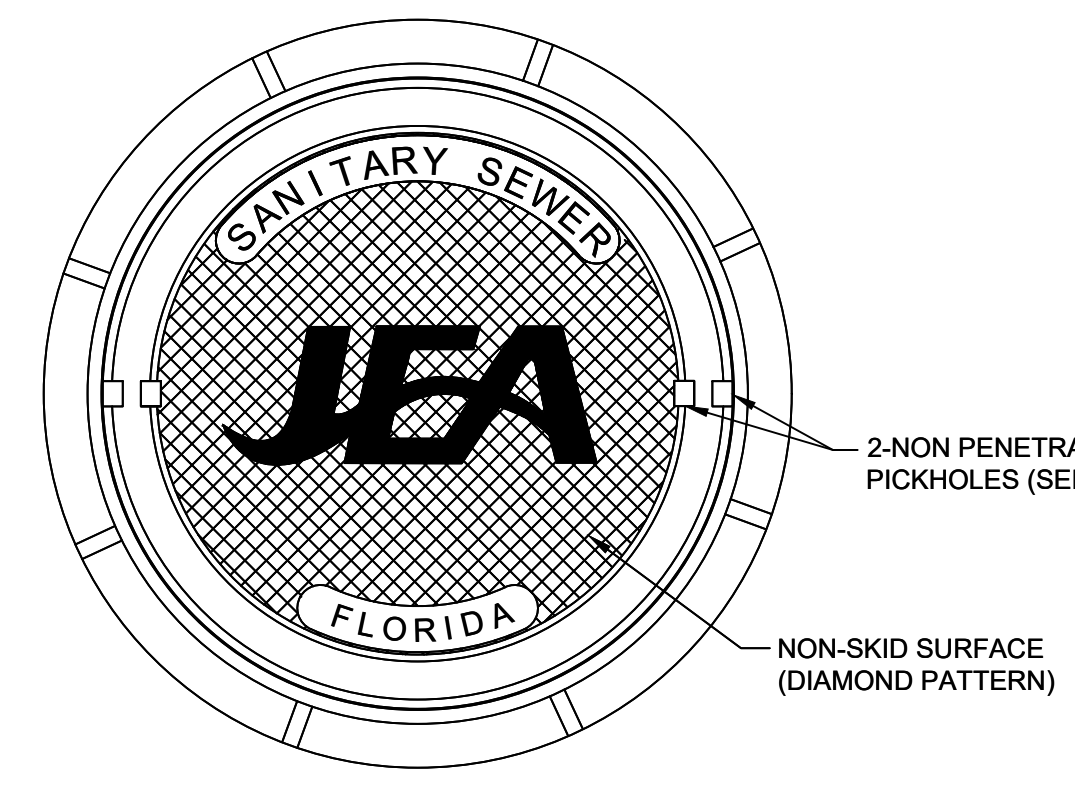

PICKHOLE DETAIL

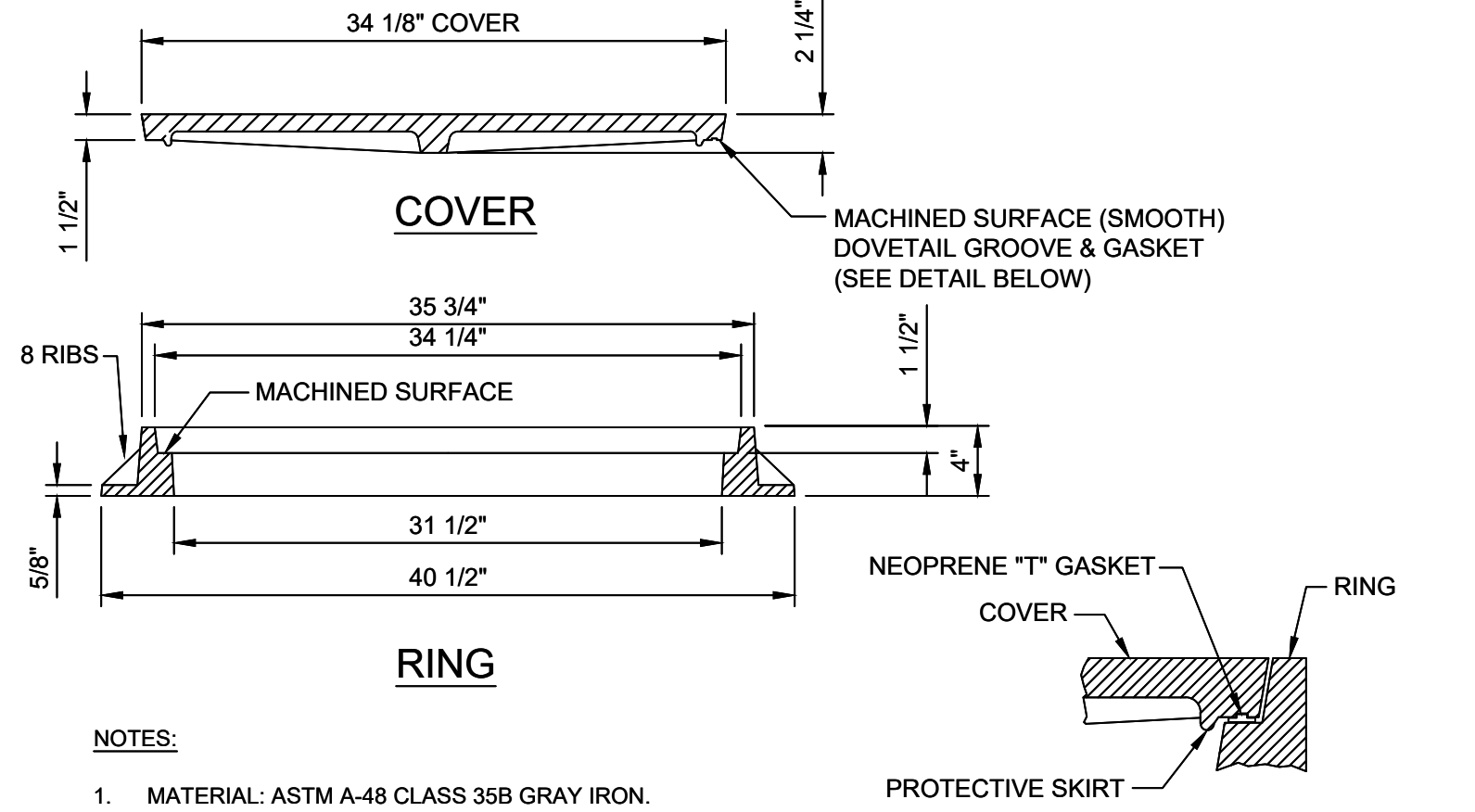

NOTES:

- MATERIAL: ASTM A-48 CLASS 35B GRAY IRON.
- RING WEIGHT 230 LBS. APPROX.
- COVER WEIGHT 230 LBS. APPROX.
- ALL DIMENSIONS ARE SHOWN IN INCHES.
- FOR MANHOLES WHICH WILL BE MAINTAINED BY JEA (INCLUDING UTILITY DEDICATION PROJECTS), THE COVER SHALL INCLUDE THE "JEA" LOGO AND A NEOPRENE GASKET.
- FOR MANHOLES WHICH WILL BE MAINTAINED BY PARTIES OTHER THAN JEA (SUCH AS PRIVATE SEWER COLLECTION SYSTEMS, PRIVATE (FORCE MAIN) PUMP OUT BOX AND SYSTEMS NOT MAINTAINED BY JEA), THE COVER SHALL INCLUDE "SANITARY SEWER" GENERIC LETTERING (NO "JEA" LOGO OR NEOPRENE GASKET).
- SEAL ALL EXTERIOR JOINTS PER PLATE S-17.

GROOVE & GASKET DETAIL

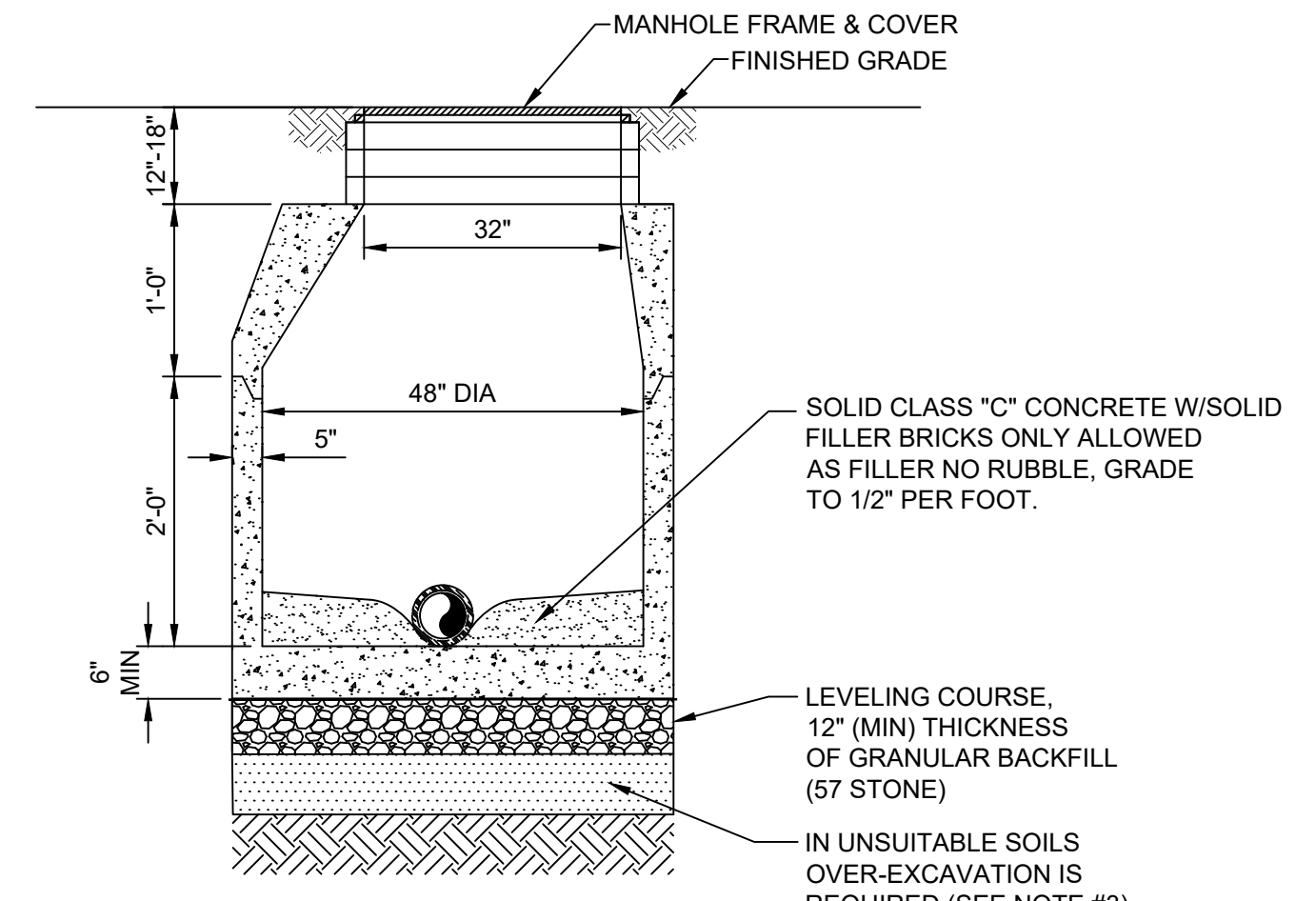

TYPE - "C" MANHOLE

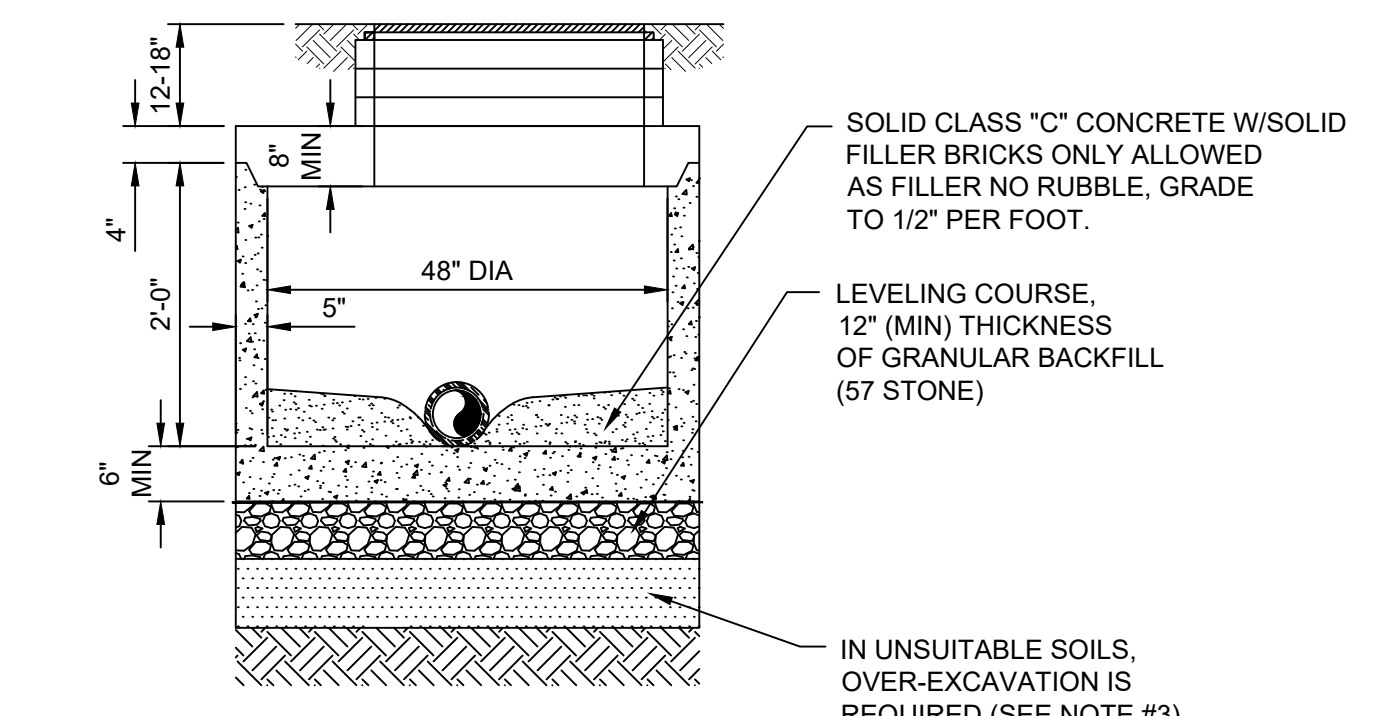

TYPE - "C" MANHOLE WITH FLAT TOP

SECTION VIEWS

NOTES:

- PRECAST MANHOLE SECTIONS TO BE MANUFACTURED IN ACCORDANCE WITH THE LATEST EDITIONS OF A.S.T.M. C-478 WITH 4000 LB. CONC., TYPE II CEMENT. ALL LIFTING HOLES AND OUTSIDE INSERTS SHALL BE FILLED WITH NON-SHRINK GROUT AND COATED WITH BITUMINOUS WATERPROOFING MATERIAL.
- THE INTERIOR AND EXTERIOR OF MANHOLE AND INTERIOR OF ADJUSTMENT RINGS SHALL BE GIVEN TWO COAT OF BITUMINOUS WATERPROOFING MATERIAL.
- IN SILTS, CLAY OR HIGHLY ORGANIC SOILS (FINE-GRAINED SOILS INCLUDING SOIL GROUPS ML, CL, OL, MH, CH, OH AND PT) THE SOILS SHALL BE OVER-EXCAVATED AN ADDITIONAL 24" (AT A MIN.) AND BACKFILLED WITH AASHTO CLASS A-3 SOIL (COMPACTED TO 98%, ASTM D1557) OR OVER-EXCAVATE AN ADDITIONAL 12" (AT A MIN.) AND BACKFILL WITH GRANULAR BACKFILL (57 STONE).
- SEAL ALL EXTERIOR JOINTS PER PLATE S-17.

**SANITARY SEWER TYPE "C" MANHOLE
8"-21" SEWERS**

JANUARY 2025 PLATE S-6

PRECAST SEWER MANHOLE JOINT DETAIL

JANUARY 2025 PLATE S-17

SANITARY SEWER MANHOLE FRAME AND COVER

JANUARY 2025 PLATE S-1

NO.	BY	DATE	REVISIONS
1			
2			
3			
4			
5			

DESIGNER:	DESIGN ENGINEER
DRAWN BY:	FLORIDA REGISTRATION NO.
CHECKED BY:	
DATE:	

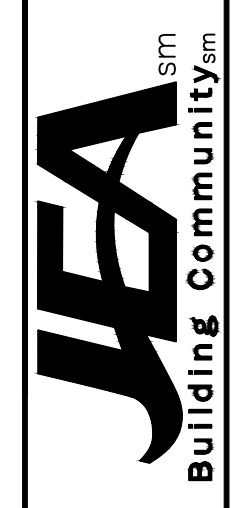

**JEA STANDARD
SANITARY SEWER DETAILS**

PROJ. NO.	JANUARY 2025
DATE:	AS NOTED
SHEET NO.	5
DRAWING NO.	SS-STD-1

PVC PIPE RESTRAINT NOTES:

- THIS SCHEDULE SHALL BE UTILIZED ON ALL WATER, SEWER FORCE MAIN OR RECLAIMED WATER SYSTEMS. ALL FITTINGS SHALL BE RESTRAINED TO LENGTHS INDICATED ON THE ABOVE SCHEDULE, AT A MINIMUM.
- ASSUMPTIONS: PVC PIPE, SAFETY FACTOR=1.5, TEST PRESSURE=150PSI, SOIL=GM OR SM, TRENCH TYPE 3, DEPTH OF COVER=30 INCHES FOR 20" AND SMALLER PIPE SIZE OR 36 INCHES FOR 24" AND LARGER PIPE SIZE.
- BENDS AND VALVES: SHALL BE RESTRAINED ON EACH SIDE OF FITTING.
- VERTICAL OFFSETS: ARE APPROX. 3 FEET COVER ON TOP AND APPROX. 8 FEET COVER ON BOTTOM. PER THE DETAILS, LU IS THE RESTRAINED LENGTH FOR THE UPPER (TOP) LEVEL. LI IS THE RESTRAINED LENGTH FOR THE LOWER (DEEPER) LEVEL. ASSUME 45 DEGREE BENDS.
- TEES: TOTAL LENGTH BETWEEN FIRST JOINTS OR RESTRAINED LENGTH ON EITHER SIDE OF TEE (RUN) SHALL BE A TOTAL DISTANCE OF 30 FEET (MIN). SEE SCHEDULE ABOVE FOR RESTRAINED LENGTH ON TEE "BRANCH" LINE.
- HOPE TO PVC TRANSITIONS: THE PVC PIPE SIDE SHALL BE RESTRAINED 35 FT (MIN).
- THE INSTALLATION OF BELL HARNESS RESTRAINTS AT PVC JOINTS (DR-18 & 25 PIPE) SHALL BE COMPLETED PER THE MANUFACTURERS RECOMMENDATION, WHICH INCLUDES NOT OVER TIGHTENING THE PARALLEL RODS/NUTS. THESE NUTS SHOULD ONLY BE SNUG TIGHT. THE HOME MARKS ON THE PIPE SHOULD ALWAYS BE VISIBLE AFTER THE RESTRAINT IS INSTALLED. OVERHOMING THE JOINT MAY CAUSE A FAILURE AT THE BELL RESULTING IN A SERVICE OUTAGE.

NOMINAL PIPE SIZE (IN.)	HORIZONTAL BENDS				VERTICAL OFFSETS 45° BENDS (SEE NOTE 4)		VALVES OR DEAD ENDS L (FT.)	REDUCERS		TEES SEE NOTE 5		
	90° BENDS L (FT.)	45° BENDS L (FT.)	22.5° BENDS L (FT.)	11.25° BENDS L (FT.)	UPPER L (FT.)	LOWER L (FT.)		SIZE (IN.)	L (FT.)	RUN SIZE (IN.)	BRANCH SIZE (IN.)	L (FT.)
4	21	9	5	3	17	3	47	6x4	34	4	4	F.O.
6	30	13	6	3	23	4	66	8x6	36	4	6	F.O.
8	38	16	8	4	30	6	86	8x4	62	8	8	F.O.
10	45	19	9	5	36	7	103	10x8	35	6	8	F.O.
12	53	22	11	6	43	8	121	10x6	63	10	10	F.O.
14	61	26	13	6	50	9	140	12x10	36	6	8	F.O.
16	66	28	14	7	55	10	154	12x8	64	12	12	F.O.
18	73	30	15	8	60	11	170	16x12	66	8	10	F.O.
20	79	33	16	8	66	12	186	16x10	92	10	12	F.O.
24	79	33	16	8	77	15	185	20x18	35	16	16	F.O.
30	93	39	19	10	97	17	222	20x16	66	20	20	F.O.
36	106	39	21	11	107	20	257	20x12	117	24	24	F.O.
42	117	49	24	12	120	24	289	24x20	56	30	30	F.O.
48	144	53	26	13	133	26	321	24x18	80	36	36	F.O.
								30x24	78	42	42	F.O.
								30x20	121	48	48	F.O.
								36x30	78	48	48	F.O.
								36x24	141	48	48	F.O.
								42x36	75	48	48	F.O.
								42x30	140	48	48	F.O.
								48x42	75	48	48	F.O.
								48x36	139	48	48	F.O.

PVC PIPE RESTRAINT JOINT SCHEDULE
 JANUARY 2025 PLATE S-38A

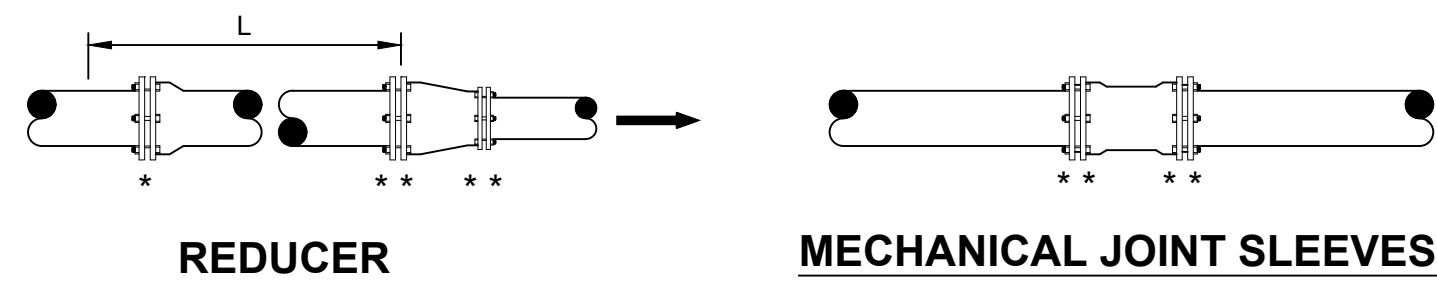
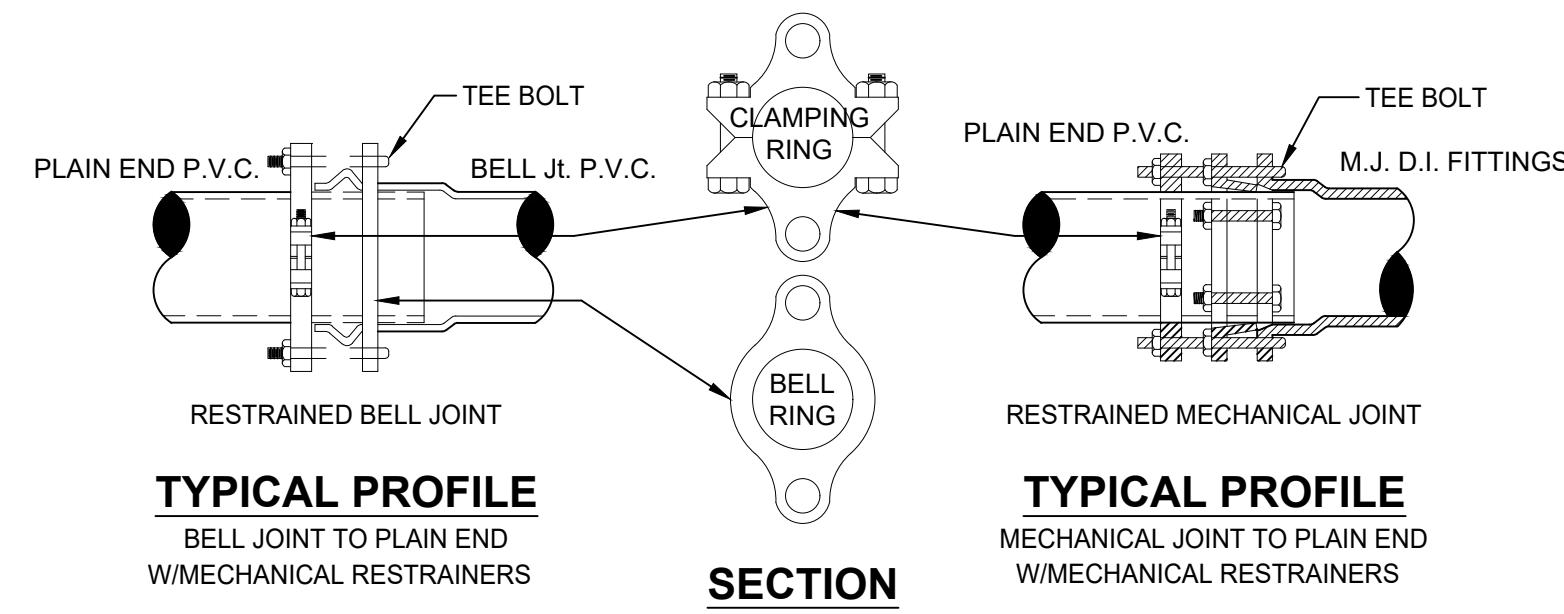

NO. OF TIE RODS REQUIRED	
3" - 8"	DIAMETER MAIN - 2 TIE RODS REQUIRED PER JOINT (3/4" ROD)
10" - 12"	DIAMETER MAIN - 4 TIE RODS REQUIRED PER JOINT (3/4" ROD)
14" - 16"	DIAMETER MAIN - 6 TIE RODS REQUIRED PER JOINT (3/4" ROD)
18" - 20"	DIAMETER MAIN - 8 TIE RODS REQUIRED PER JOINT (3/4" ROD)
24"	DIAMETER MAIN - 12 TIE RODS REQUIRED PER JOINT (3/4" ROD)
30" - 36"	DIAMETER MAIN - 14 TIE RODS REQUIRED PER JOINT (1" ROD)
42" - 48"	DIAMETER MAIN - 16 TIE RODS REQUIRED PER JOINT (1 1/4" ROD)
54"	DIAMETER MAIN - 18 TIE RODS REQUIRED PER JOINT (1 1/4" ROD)

DEAD - END THRUST COLLAR ANCHOR
 TO BE USED INSTEAD OF TOTAL RESTRAINED LENGTH (OPTIONAL) SIZE AS PER THRUST BLOCK DETAIL (W-36). SEE DETAILS W-36 & W-37.

GENERAL NOTE:

- PAY ITEM " " " " DENOTES A RESTRAINT WHICH IS PAID FOR ON A PER EACH BASIS.
- PAY ITEM " " " " DENOTES A RESTRAINT WHICH IS INCLUDED IN THE UNIT PRICE BID FOR FITTING OR VALVE.
- ➔ INDICATES DIRECTION OF THRUST FORCE.
- THE USE OF THRUST BLOCKS IS PROHIBITED UNLESS SPECIFICALLY APPROVED BY JEA.

MECHANICAL RESTRAINT DETAILS - I

JANUARY 2025

PLATE S-38C

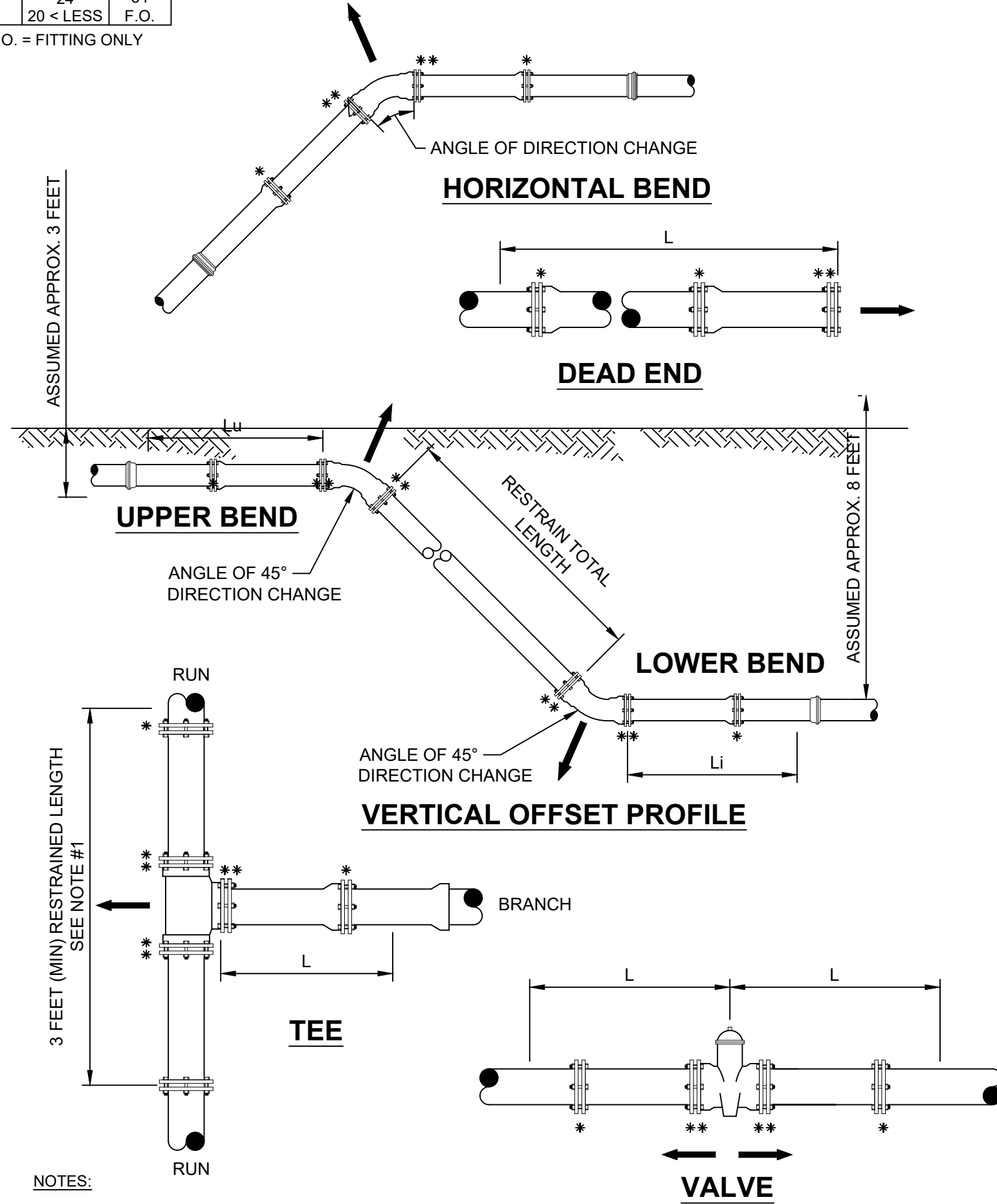

NOTES:

- TOTAL LENGTH BETWEEN FIRST JOINTS OR RESTRAINED LENGTH ON EITHER SIDE OF TEE (RUN) SHALL BE A TOTAL DISTANCE OF 6 FEET (MIN.). THE PROJECT ENGINEER CAN INCREASE THIS LENGTH TO REDUCE THE NUMBER OF RESTRAINTS REQUIRED. ANY CHANGES TO THIS TABLE MUST BE SUBMITTED TO JEA FOR APPROVAL.
- PAY ITEM " " " " DENOTES A RESTRAINT WHICH IS PAID FOR ON A PER EACH BASIS.
- PAY ITEM " " " " DENOTES A RESTRAINT WHICH IS INCLUDED IN THE UNIT PRICE BID FOR FITTING OR VALVE.

MECHANICAL RESTRAINT DETAILS - II

JANUARY 2025

PLATE S-38D

NO.	BY	DATE	REVISIONS				
			1	2	3	4	5
			DESIGNER:				
			DRAWN BY:				
			DATE:				
			CHECKED BY:				
			DATE:				
			DESIGN ENGINEER:				
			FLORIDA REGISTRATION NO.:				
JEA STANDARD SANITARY SEWER DETAILS							
PROJ. NO.	DATE: JANUARY 2025		AS NOTED				
SHEET NO. 5							
DRAWING NO. S-STD-1							

NOTE:
ANGLE BETWEEN INFLUENT FORCE
MAIN AND GRAVITY EFFLUENT PIPE
SHALL BE BETWEEN 135° - 180° UNLESS
APPROVED OTHERWISE BY JEA.

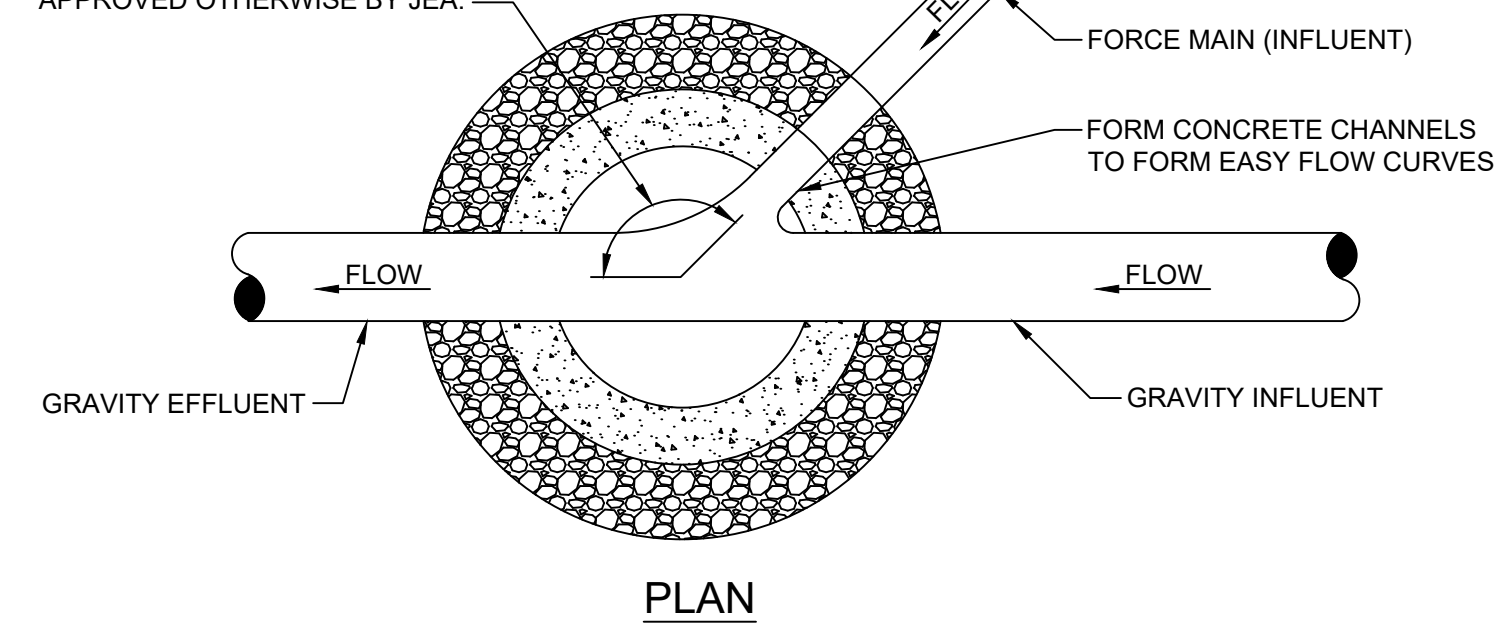

PLAN

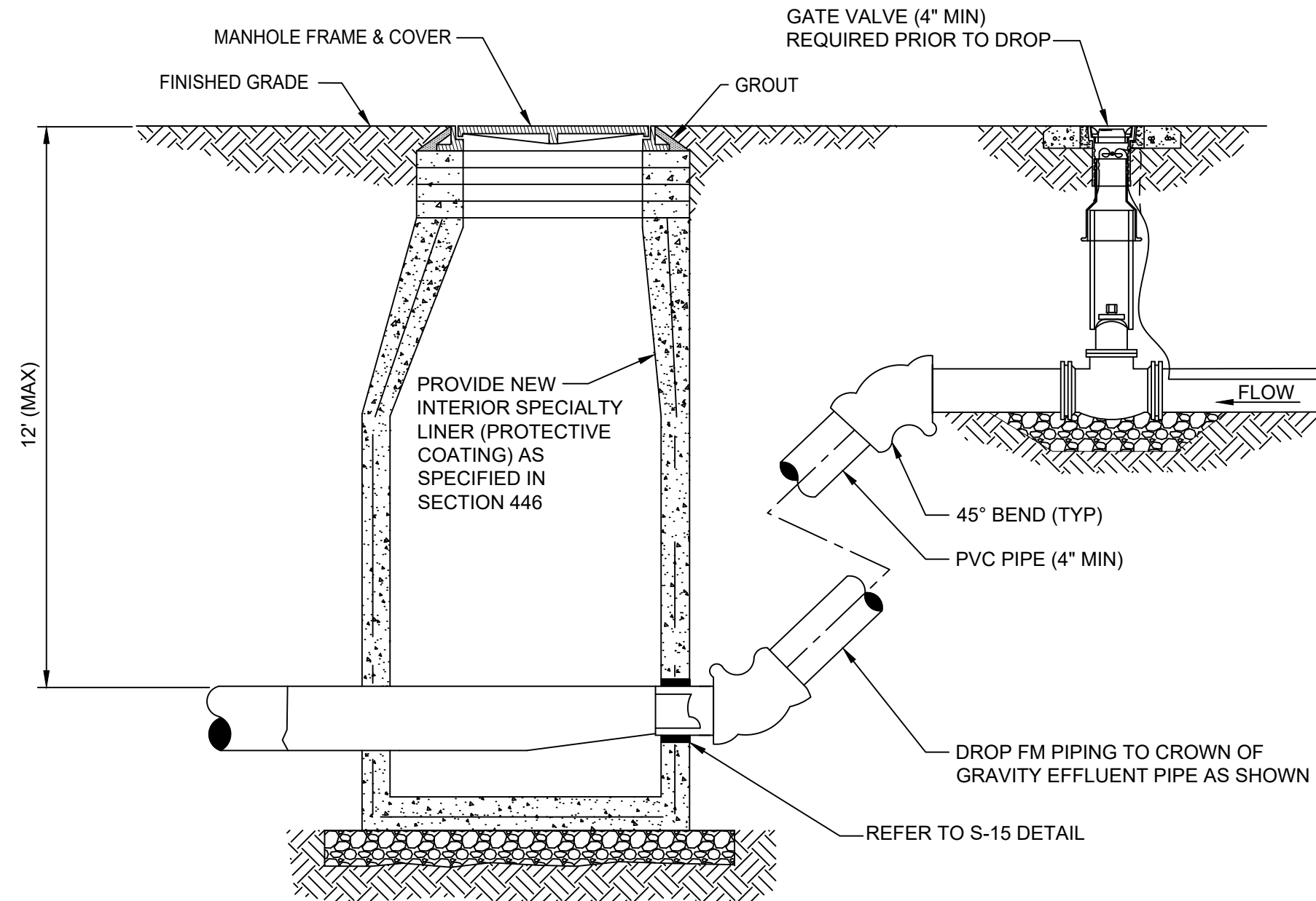

SECTION

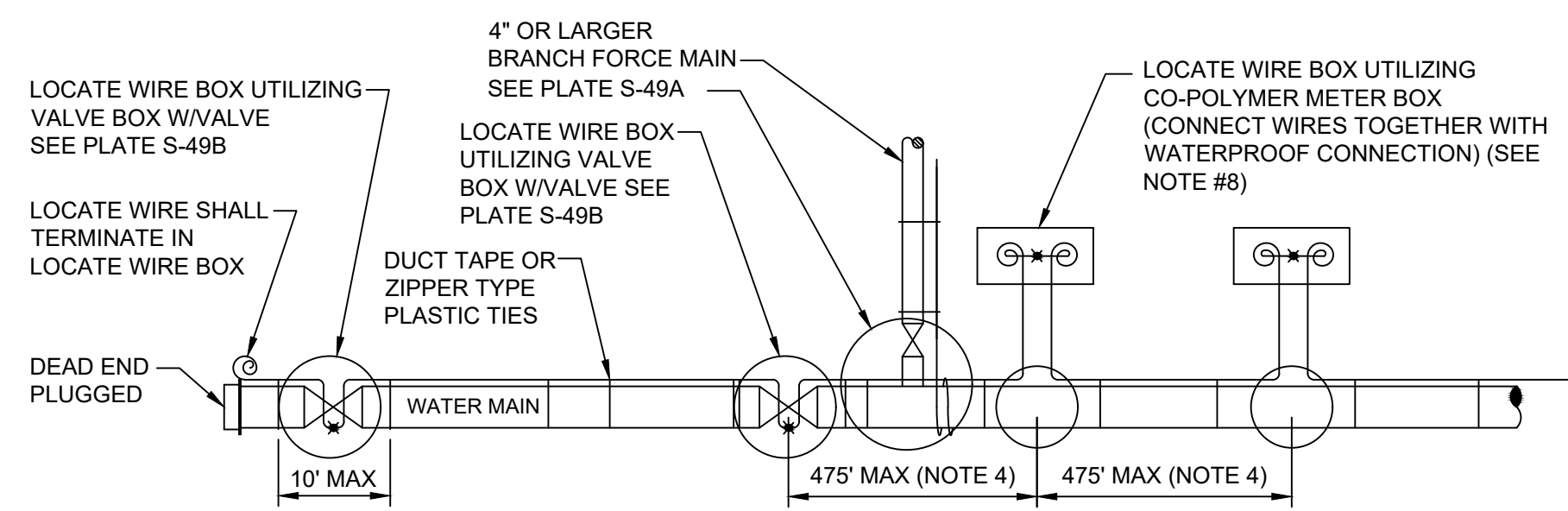

LOCATE WIRE SYSTEM

NOTES:

- LOCATING WIRE TO BE INSTALLED IN EITHER THE ONE OR ELEVEN O'CLOCK POSITION ON ALL DUCTILE IRON OR PVC (PRESSURE MAINS). LOCATE WIRE SHALL ALSO BE INSTALLED ON ALL (HDPE) POLY MAIN PIPING (1:00 OR 11:00 POSITION, IF POSSIBLE).
- SECURE LOCATING WIRE TO PVC FORCE MAIN BY USE OF DUCT TAPE OR ZIPPER TYPE PLASTIC TIE STRAPS SPACED AT A MAXIMUM DISTANCE OF TEN (10') AND AT EACH SIDE OF BELL JOINT OR FITTING.
- THE ENTIRE LOCATING SYSTEM SHALL BE SUBJECT TO TESTING TO DETERMINE ITS RELIABILITY. WHERE INSTALLED UNDER PAVEMENT AREAS, TESTING SHALL BE DONE PRIOR TO THE PLACEMENT OF PAVEMENT, UNLESS APPROVED OTHERWISE BY JEA.
- LOCATING WIRE SHALL TERMINATE WITHIN AN ACTIVE VALVE BOX (WITH A VALVE) OR A METER BOX (IF NO VALVE) AT 475' INTERVALS. SEE DETAIL PLATE S-49B. WIRE CONNECTIONS BELOW GROUND (OUTSIDE OF A BOX) SHALL BE AVOIDED.
- LOCATING WIRE SHALL BE 12 GAUGE COPPER WIRE WITH .03 INCHES (MINIMUM) HDPE INSULATION THICKNESS, 0.141 INCHES (MINIMUM) O.D. RATED BREAK LOAD 250LBS., UF RATED (DIRECT BURIAL), GREEN COLOR. FOR HDD INSTALLATIONS, THE LOCATE WIRE SHALL BE COPPER CODED STEEL AS SPECIFIED IN SPEC. SECTION 750.
- ⊗ INDICATES THAT THE WIRES ARE CONNECTED TOGETHER WITH WATERPROOF CONNECTION. (SEE DETAIL W-49B)
- Ⓢ INDICATES A WIRE PIG-TAIL (24" LONG)
- AN "LV" CUT SHALL BE CARVED IN THE CONCRETE CURB AND PAINTED AT ALL LOCATE WIRE BOXES.
- FOUR LANES OF TRAFFIC (HAVING TWO LANES OF TRAFFIC IN EACH DIRECTION) OR GREATER THE LOCATE WIRE AND VALVE BOX SHALL BE OFF-SET TO THE RIGHT-OF-WAY.

LOCATE WIRE CONSTRUCTION FOR FORCE MAINS

JANUARY 2025

PLATE S-49

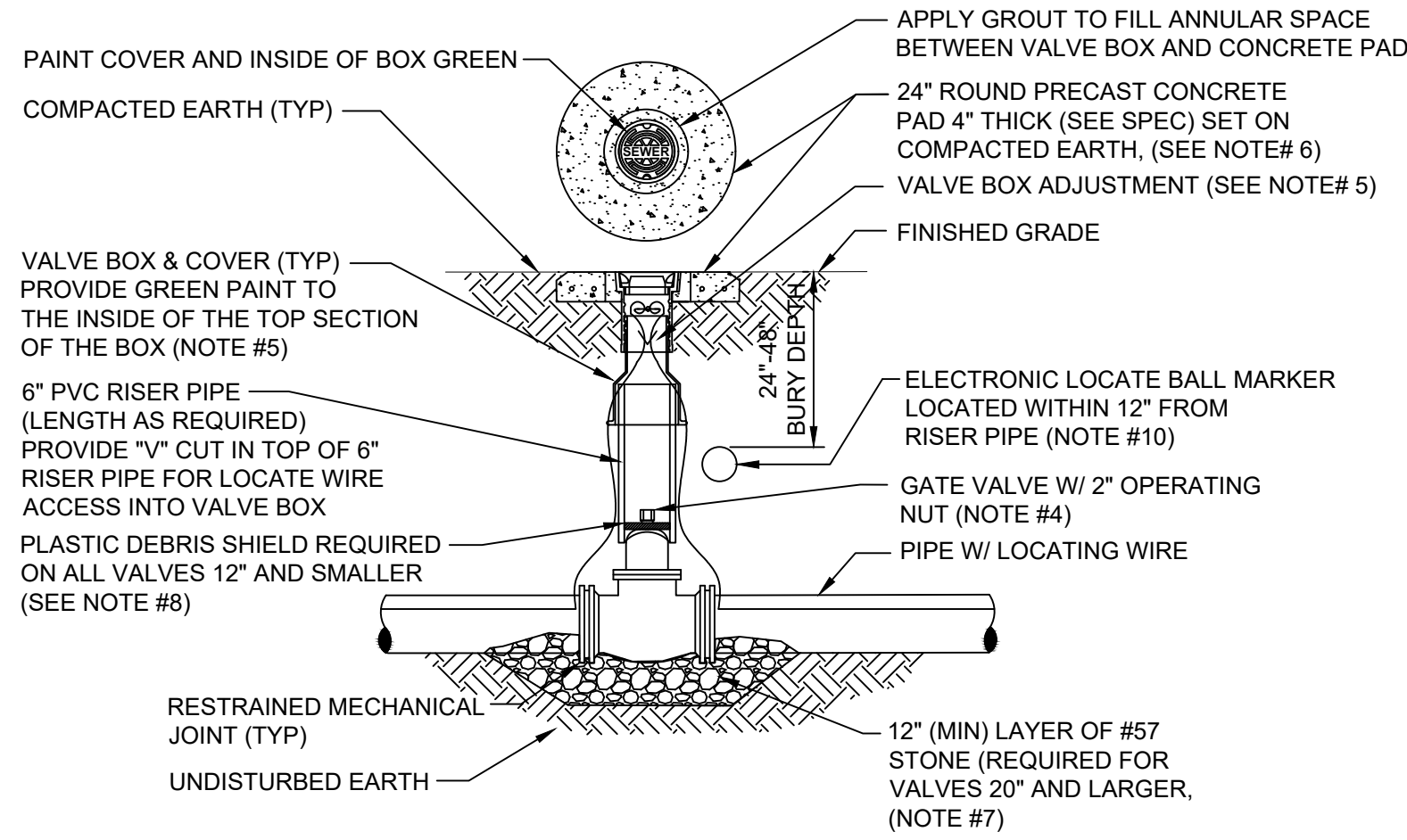

NOTES:

- FOR UNPAVED LOCATIONS, A PRECAST CONCRETE VALVE PAD SHALL BE PROVIDED AND INSTALLED FLUSH WITH GRADE. CONCRETE PAD IS NOT REQUIRED FOR VALVE LOCATED IN THE ROADWAY, UNLESS SHOWN OR NOTED OTHERWISE.
- LOCATING WIRE IS REQUIRED ON ALL PRESSURE PIPING (SEE DETAIL S-49).
- A "V" CUT SHALL BE CARVED IN THE CURB CLOSEST (ASPHALT IF NO CURB) ADJACENT TO ALL BELOW GRADE VALVES. THE "V" CUT IS TO BE PAINTED GREEN.
- IN PAVED AREAS, INSTALL VALVE AT A DEPTH TO ALLOW A 12" MIN. DISTANCE BETWEEN THE VALVE COVER PLATE AND THE TOP OF THE VALVE OPERATING NUT. OUTSIDE OF PAVED AREAS (GRASS), INSTALL VALVE AT A DEPTH TO ALLOW A 6" MINIMUM DISTANCE BETWEEN THE VALVE COVER AND THE TOP OF THE VALVE OPERATING NUT. OPERATING NUT/STEM EXTENSION SHALL BE PROVIDED (WHERE APPLICABLE) SO THAT THE OPERATING NUT WILL BE NO MORE THAN 30 INCHES BELOW FINISHED GRADE.
- FOR NEW CONSTRUCTION, THE VALVE BOX SHALL BE ADJUSTED TO MIDRANGE TO ALLOW FOR FUTURE BOX ADJUSTMENTS. ROUTE LOCATE WIRES THRU A "V" CUT IN THE TOP OF THE 6" PVC RISER PIPE FOR LOCATE WIRE ACCESS INTO VALVE BOX. THE LOCATE WIRES WITH A 24" LONG PIG-TAIL AT THE TOP SHALL BE CONNECTED TOGETHER WITH A WIRE NUT.
- BRASS IDENTIFICATION TAG INDICATING "SEWER", VALVE SIZE, DIRECTION AND TURNS TO OPEN & VALVE TYPE. PROVIDE A 1/2" HOLE IN BRASS TAG AND ATTACH TAG (TWIST WIRE AROUND TAG) TO THE END OF THE LOCATE WIRE. TAGS ARE NOT REQUIRED ON VALVES INSTALLED ON FIRE HYDRANT BRANCH LINES.
- IN LIEU OF PRECAST CONCRETE PAD, A 6" THICK X 24" (ROUND OR SQUARE) POURED CONCRETE PAD W/2 - #4 REBAR AROUND PERIMETER, MAY BE USED.
- GRAVEL SHALL BE PROVIDED UNDER ALL VALVES 20" AND LARGER. THE MINIMUM VERTICAL LIMIT OF GRAVEL IS 12" UNDER THE VALVE UP TO 1/2 THE OVERALL HEIGHT OF THE VALVE.
- FOR VALVES 12 INCH AND SMALLER, PROVIDE A WHITE OR BLACK PLASTIC DEBRIS SHIELD WHICH INSTALLS BELOW THE OPERATING NUT. THIS SHIELD SHALL CENTER THE RISER PIPE BOX OVER THE OPERATING NUT AND MINIMIZE INFILTRATION. SHIELD SHALL BE BY AFC, BOXLOK OR APPROVED EQUAL.
- ALL VALVES SHALL BE INSTALLED WITH AN ELECTRIC LOCATE MARKER. MARKER SHALL BE 4" DIA. COLOR CODED BALL MARKER (3M-1404XR FOR SEWER).

SEWER VALVE DETAIL

JANUARY 2025

PLATE S-30

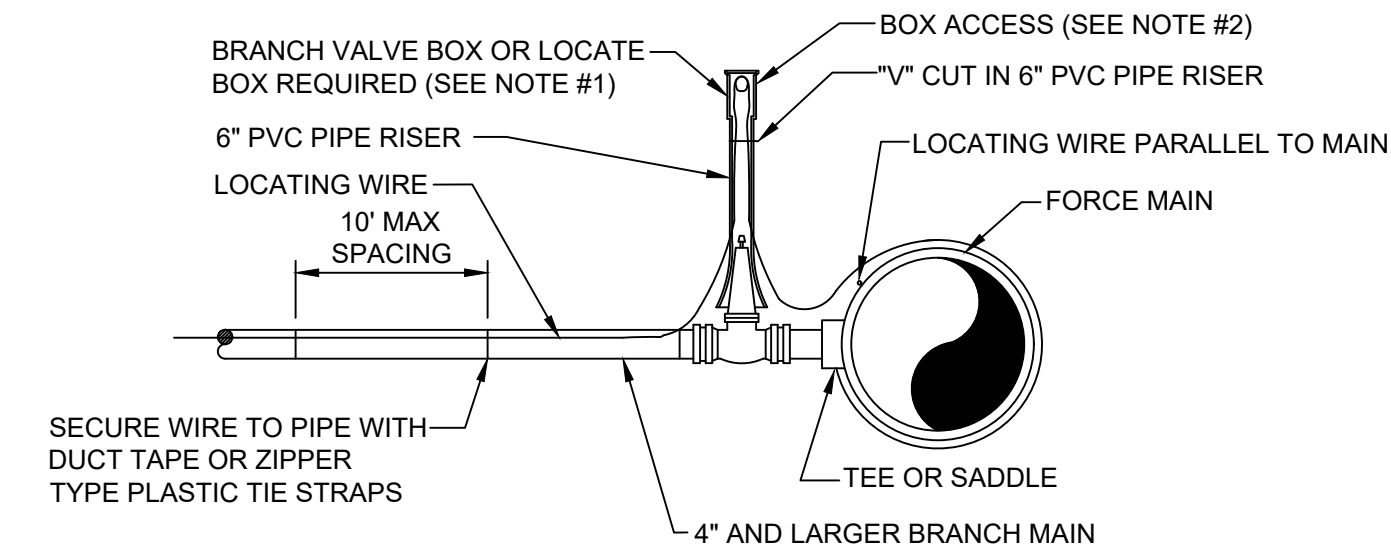

BRANCH FORCE MAIN

(4" AND LARGER SEWER MAIN)

NOTE:

- NOTE THAT THE BRANCH WIRE IS NOT CONNECTED TO THE MAIN WIRE.
- LOCATE WIRE SHALL ENTER THE VALVE BOX THROUGH A "V" CUT IN THE 6" PVC RISER PIPE SECTION (SEE S-30).
- LOCATE WIRE BOX SHALL BE INSTALLED OUTSIDE OF SIDEWALKS, DRIVEWAYS AND PAVEMENT.
- Ⓢ INDICATES A WIRE PIG-TAIL (4' LONG)

LOCATE WIRE FOR BRANCH MAIN

JANUARY 2025

PLATE S-49A

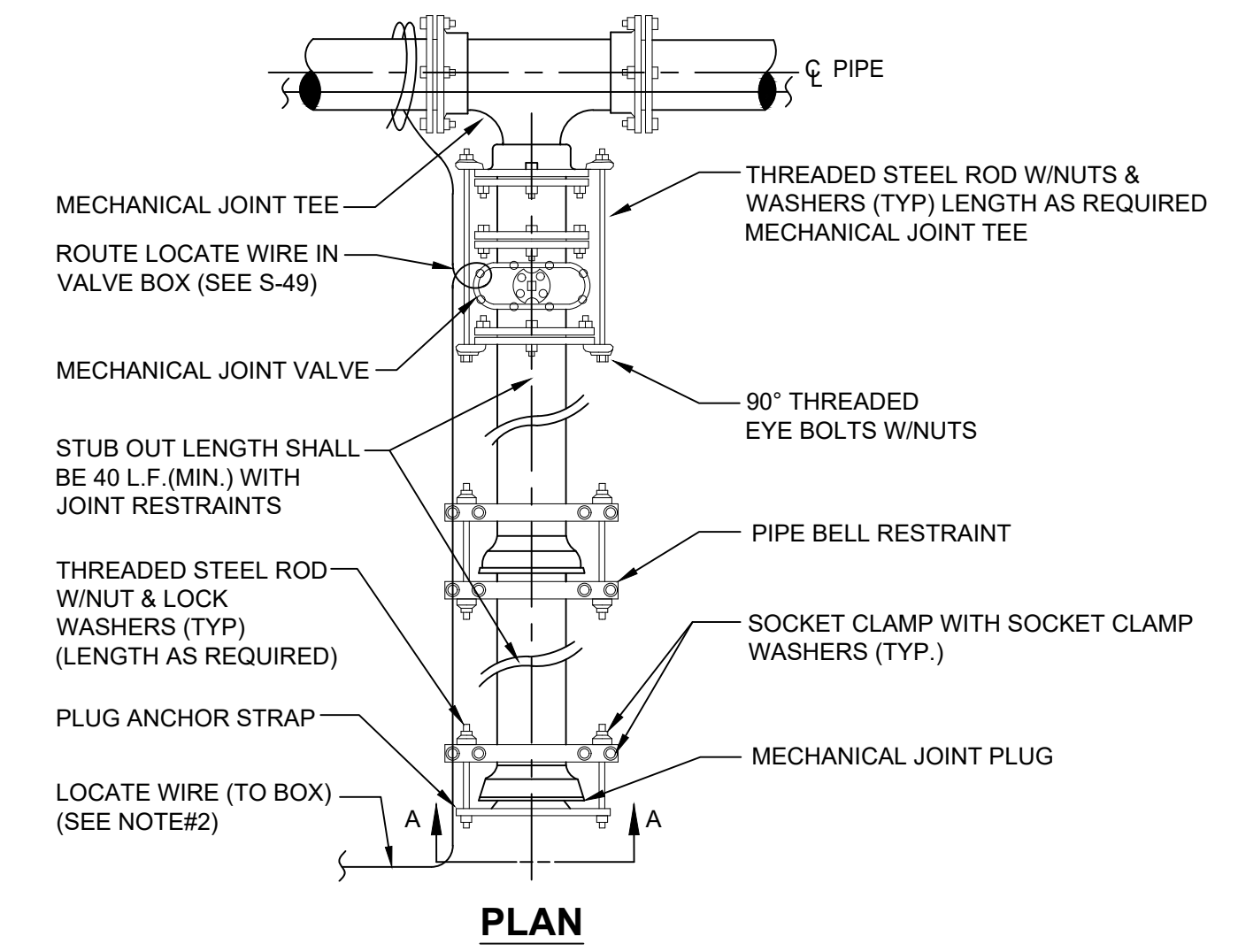

PLAN

SECTION "A-A"

NOTES:

- IN LIEU OF BELL/ROD RESTRAINTS, MECHANICAL JOINT RESTRAINTS MAY BE USED.
- LOCATING WIRE REQUIRED, UTILIZING A LOCATE WIRE BOX INSTALLED AT PLUG LOCATION.
- NUMBER OF THE RODS REQUIRED IS AS FOLLOWS:
3" - 8" DIAMETER MAIN - 2 TIE RODS REQUIRED PER JOINT (3/4" ROD)
10" - 12" DIAMETER MAIN - 4 TIE RODS REQUIRED PER JOINT (3/4" ROD)
14" - 16" DIAMETER MAIN - 6 TIE RODS REQUIRED PER JOINT (3/4" ROD)
18" - 20" DIAMETER MAIN - 8 TIE RODS REQUIRED PER JOINT (3/4" ROD)
24" DIAMETER MAIN - 12 TIE RODS REQUIRED PER JOINT (3/4" ROD)
30" - 36" DIAMETER MAIN - 14 TIE RODS REQUIRED PER JOINT (1" ROD)
42" - 48" DIAMETER MAIN - 16 TIE RODS REQUIRED PER JOINT (1 1/4" ROD)
54" DIAMETER MAIN - 18 TIE RODS REQUIRED PER JOINT (1 1/4" ROD)
- THE LOCATION OF THE DEAD END PLUG SHALL NOT BE UNDER PAVEMENT, IF POSSIBLE. THE STUB OUT SHALL EXTEND BEYOND THE INTERSECTION AREAS OR ROAD CROSSING BY 10 FEET (MIN.) WHERE POSSIBLE.

PLUGGED DEAD END USING MECHANICAL RESTRAINTS

JANUARY 2025

PLATE S-44

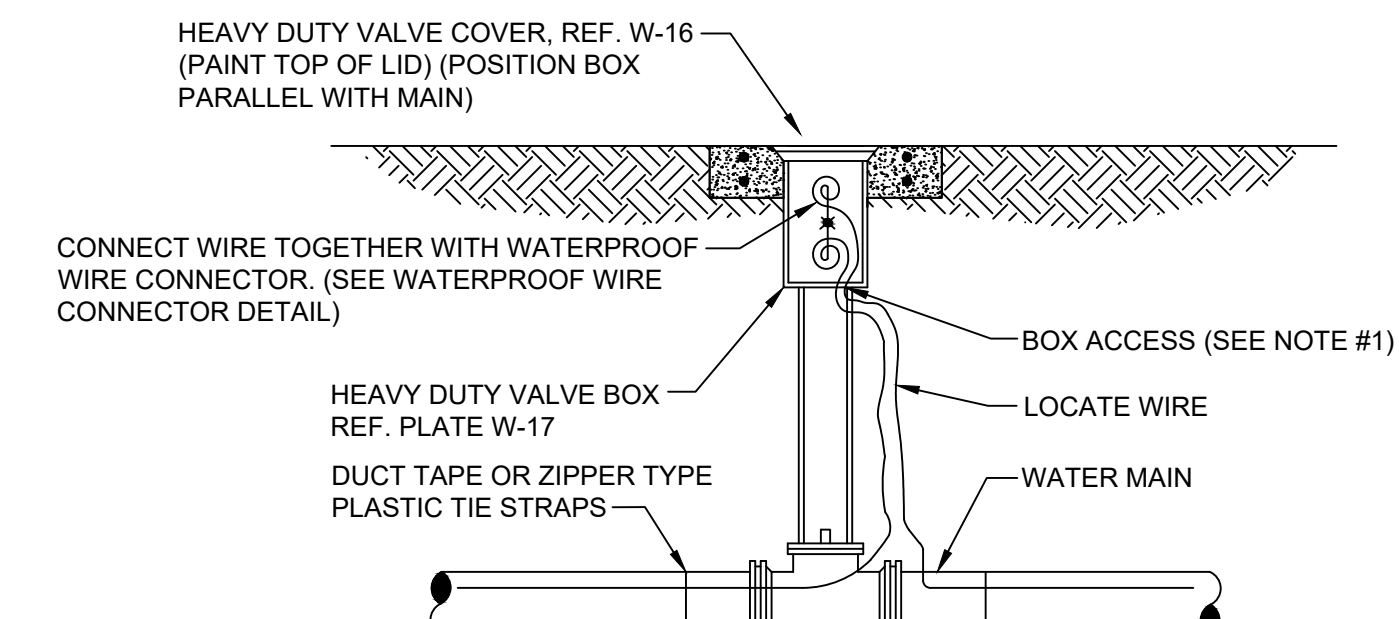

LOCATE WIRE BOX UTILIZING VALVE BOX

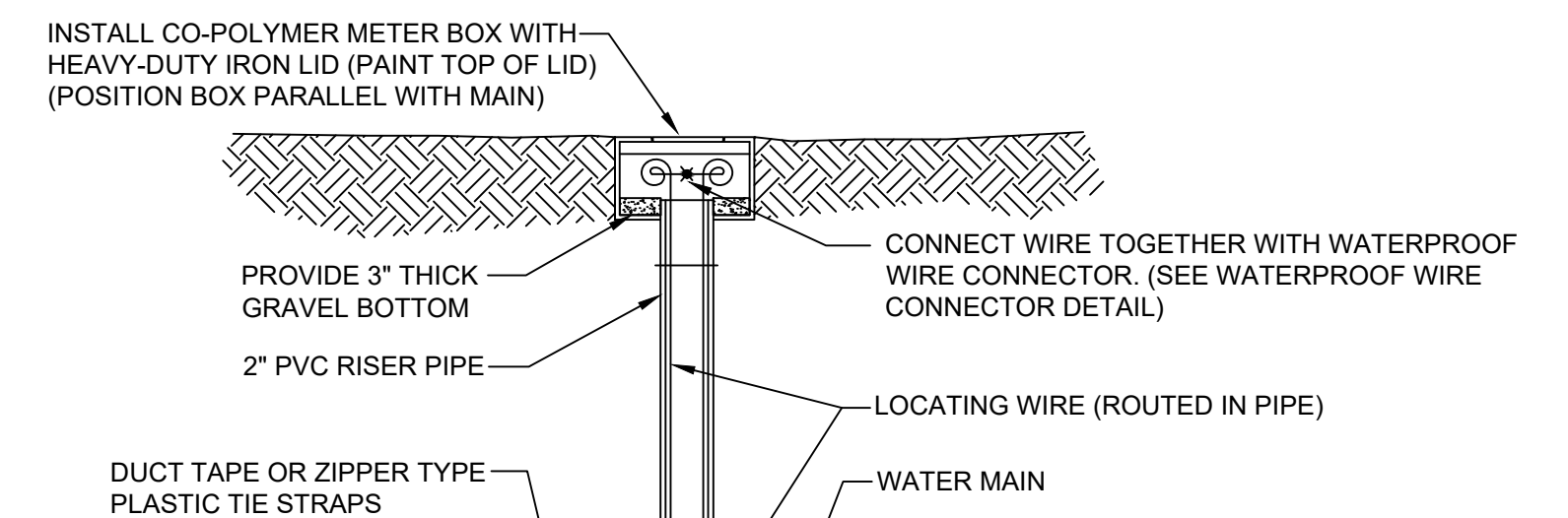

LOCATE WIRE BOX UTILIZING METER BOX

LOCATE WIRE BOX

JANUARY 2025

PLATE S-49B

NO.		BY		DATE		REVISIONS	
1							
2							
3							
4							
DESIGNER:		DRAWN BY:		CHECKED BY:		DATE:	
DESIGN ENGINEER		FLORIDA REGISTRATION NO.					
JEA STANDARD		SANITARY SEWER DETAILS					
NO. SHEETS	1	DATE:	JANUARY 2025	SCALE:	AS NOTED		
SHEET NO.	5						
DRAWING NO.	S-STD-1						

