

INSTRUCTIONS:

1. CONTRACTOR SHALL USE THIS DRAWING FILE TO CREATE SHOP DRAWINGS FOR JEA REVIEW.
2. PLEASE CONTACT ARISS FAJARDO AT FAJAAJ@JEA.COM FOR QUESTIONS OR ADDITIONAL INFORMATION.
3. DO NOT PRINT THIS SHEET IN SUBMITTAL SET.

NO.	BY	DATE	REVISIONS	<p style="color: green; text-align: center;">ELECTRICAL SCHEMATIC</p> <p style="color: blue; text-align: center;">MANUFACTURER ADDRESS1 ADDRESS2</p> <p style="color: blue; text-align: center;">CONTACT_NAME CONTACT_NUMBER</p>		DESIGNER:	SHEET TITLE: INSTRUCTION SHEET		
6.						DRAWN BY:	PROJECT: --- PROJECT NAME ---		
5.						DATE:	ACROSS THE LINE LIFT STATION DIAGRAM		
4.						CHECKED BY:			
3.						DATE:	JOB No:	SHEET	OF
2.						2026 STANDARD PACKAGE, REV. 0	12345678	0	14
1.									

GENERAL NOTES:

1. REFER TO "433 PUMP STATION ELECTRICAL" FOR FURTHER DETAILS THAT MUST BE ADHERED TO SUCH AS WIRE, CONTACTOR, AND CIRCUIT BREAKER SIZING.
2. THIS DRAWING IS AN EXAMPLE OF HOW OVERALL CABINET IS TO BE DESIGNED. THE DRAWING WILL NEED TO BE REVISED BASED ON THE PUMP MANUFACTURER, SIZE AND NUMBER OF PUMPS. THINGS THAT WILL CHANGE ARE ENCLOSURE SIZE, CIRCUIT BREAKER SIZE, WIRE SIZE, VFD SIZE, AND OTHER ITEMS. REFER TO SPECIFICATIONS FOR FURTHER DETAILS.
3. REFER TO "433 PUMP STATION ELECTRICAL" HEAT LOAD CALCULATIONS SECTION AND ENCLOSURE SPECIFICATIONS TO SIZE ENCLOSURE CORRECTLY.
4. VFDs SHALL BE BOLTED TO A REMOVABLE PLATE THAT WILL THEN BE CONNECTED TO THE BACK OF THE ENCLOSURE WITH A GASKET. THE BACK OF THE ENCLOSURE SHALL HAVE STUDS TO ATTACH THE PLATE TO. THIS PLATE IS TO BE ADEQUATELY DESIGNED TO SUPPORT THE VFD. ENCLOSURE CUTOUT SHALL BE SIZED A MINIMUM OF 2.75" WIDER AND 3.5" HIGHER ON EACH SIDE OF THE MANUFACTURER RECOMMENDED CUTOUT FOR 40HP VFDs. THIS WILL RESULT IN A CUTOUT THAT IS NO LESS THAN 5.5" WIDER AND 7" HIGHER THAN THE MANUFACTURER'S SPECIFICATION. ADDITIONALLY THIS DISTANCE WILL INCREASE PROPORTIONATELY WITH THE SIZE OF THE VFD. FOR EXAMPLE: 80HP VFDs REQUIRE A CUTOUT THAT IS 5.5" WIDER AND 7.0" HIGHER ON EACH SIDE (A TOTAL OF 11" WIDER AND 14" HIGHER) OF THE MANUFACTURER SPECIFIED CUTOUT. THIS REQUIREMENT IS TO ENSURE THAT A FUTURE REPLACEMENT OF A VFD WILL ALLOW FOR DIFFERENT VFD DIMENSIONS.
5. VFDs SHALL BE RATED FOR CORROSIVE ENVIRONMENTS AND DRIVE CONTROL BOARDS SHALL BE CONFORMAL COATED TO PROTECT AGAINST CORROSION. REFER TO "495 VARIABLE FREQUENCY DRIVES".
6. VFD ENCLOSURES LOCATED OUTSIDE SHALL BE NEMA 12/3R WITH THE VFD HEAT SINKS VENTED OUT THE BACK. REFER TO DRAWINGS FOR FURTHER DETAILS.
7. THE REAR SUNSHIELD SHALL HAVE A REMOVABLE COVER WITH HANDLES TO ALLOW ACCESS TO THE VFD HEAT SINKS FOR CLEANING AND MAINTENANCE. THE HEAT SHIELD WILL HAVE STUDS WITH WING NUTS FOR ATTACHING THE REMOVABLE COVER.
8. SEAL LEAK/OVERTEMP RELAYS MUST BE CHANGED AS REQUIRED BY PUMP MANUFACTURER AND ADJUSTED TO RECOMMENDED SETTINGS.
9. REFER TO "433 RADIO AND ANTENNA POLE/TOWER SELECTION".
10. ENSURE GOOD ELECTRICAL CONTACT BETWEEN BACK PANEL AND ALL MECHANICAL GROUND CONNECTIONS.
11. REFER TO NOTES AND DETAILS ON ALL DRAWING SHEETS FOR MORE MANUFACTURING DETAILS.
12. THE SURGE PROTECTION DEVICE (SPD) IS TO BE SHIPPED LOOSE FOR MOUNTING AT THE DISCONNECT IN THE FIELD. THE CORRECT SPD MUST BE SELECTED BASED ON THE SERVICE VOLTAGE: 240V DELTA HI-LEG OR 480V WYE.
13. ALL FIELD WIRING SHALL BE #12 AWG STRANDED, TIN-PLATED COPPER. APPLY DIELECTRIC GREASE TO ENDS TO PREVENT CORROSION.
14. ALL CONTROL WIRING SHALL BE #18 AWG STRANDED, TIN-PLATED COPPER. APPLY DIELECTRIC GREASE TO ENDS TO PREVENT CORROSION.
15. ALL WIRES IN CONTROL PANEL SHALL BE TERMINATED WITH FERRULES. APPLY DIELECTRIC GREASE TO THE ENDS TO PREVENT CORROSION.
16. ALL MOUNTING SCREWS SHALL BE STAINLESS STEEL, DRILLED AND TAPPED (NO SELF-TAPPING SCREWS ARE ALLOWED).
17. PANEL MUST MEET UL508A CONTROL PANEL WITH UL 508A LABEL
18. -
19. THIS DRAWING IS FOR 240VAC SERVICE. THE TAPS ON THE TRANSFORMER MUST BE CONNECTED FOR 240VAC.
20. ALL TERMINALS, RELAYS, SURGE SUPPRESSORS, BREAKERS, AND OTHER DEVICES MUST BE LABELED.
21. INSTALL PLUGGABLE JUMPERS ON TERMINALS WHERE INDICATED. APPLY DIELECTRIC GREASE TO JUMPERS TO PREVENT CORROSION.
22. USE 6MM FERRULES FOR WIRES TERMINATING AT PLC.
23. ALL WIRES TERMINATING AT PLC RACK MUST BE ROUTED THROUGH WIREWAY FROM BELOW.
24. ALL ANALOG SIGNAL WIRING SHALL BE SHIELDED CABLE WITH THE SHIELD GROUNDED ONLY AT ONE POINT.
25. THIS DRAWING IS FOR A DUPLEX PUMP STATION. TRIPLEX PUMP STATIONS REQUIRE MORE PUMP CONTROLS.

TABLE OF CONTENTS:

1. GENERAL NOTES
2. SCADA RTU - FRONT VIEW
3. SCADA RTU - BACK PANEL LAYOUT
4. SCADA RTU - 120 VAC VOLTAGE
5. SCADA RTU - 24 VDC VOLTAGE
6. SCADA RTU - SIMOCODE CONTROL WIRING
7. SCADA RTU - PLC DIGITAL I/O
8. SCADA RTU - PLC ANALOG INPUT
9. SCADA RTU - PLC & RADIO CONNECTION
10. SCADA RTU - 24 VDC TERMINAL BLOCK LAYOUT
11. SCADA RTU - 120 VAC TERMINAL BLOCK LAYOUT
12. MCC - FRONT PANEL VIEW
13. MCC - BACK PANEL LAYOUT
14. MCC - PANEL MAIN VAC VOLTAGE

DRAWING LAYER COLOR LEGEND:

- GREY - NOTES
- BLACK - ELECTRICAL SCHEMATIC WIRING DIAGRAMS AND DEVICES
- BLUE - PART IDENTIFICATION
- PURPLE - WIRE NUMBERS
- GREEN - FIELD DEVICES AND WIRING OUTSIDE ENCLOSURE (DASHED)
- RED - FUTURE DEVICES AND WIRING
- TEAL - DIMENSIONS

CONTROL WIRE UL508A COLOR:

- RED - 120 VAC
- WHITE - NEUTRAL
- BLUE - +24 VDC
- WHITE / BLUE STRIPE - 0 VDC

NO.	BY	DATE	REVISIONS	ELECTRICAL SCHEMATIC	JEA Building Community sm	DESIGNER:	SHEET TITLE: GENERAL NOTES
6.				MANUFACTURER		DRAWN BY:	PROJECT: --- PROJECT NAME ---
5.				ADDRESS1		DATE:	ACROSS THE LINE LIFT STATION DIAGRAM
4.				ADDRESS2		CHECKED BY:	
3.				CONTACT_NAME		DATE:	JOB No: 12345678
2.				CONTACT_NUMBER		2026 STANDARD PACKAGE, REV. 0	SHEET 1 OF 14
1.							

FRONT VIEW

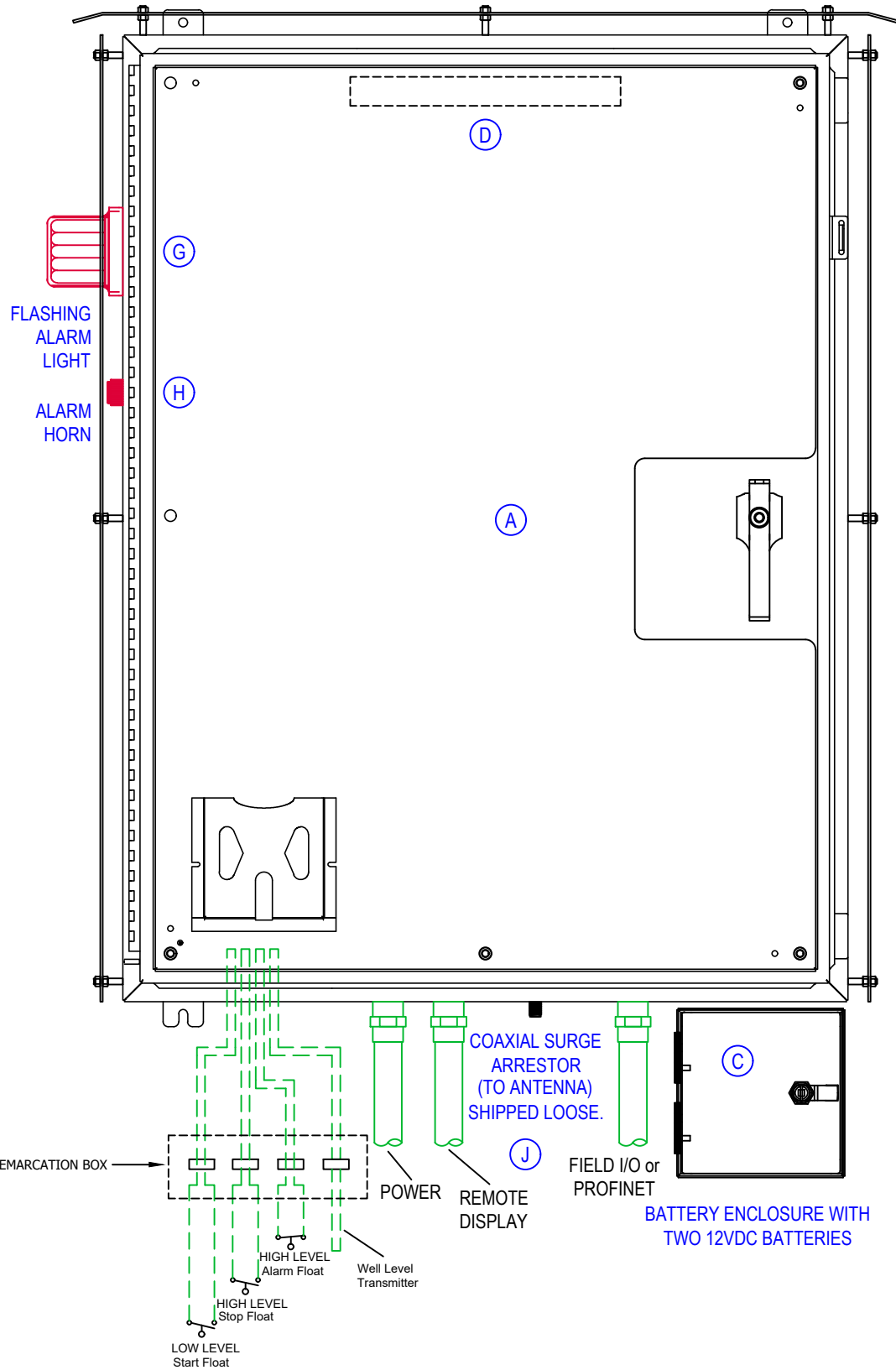

BILL of MATERIAL

QTY	MANUFACTURER	PART NUMBER	DESCRIPTION
1	OEM	CUSTOM ENCLOSURE	SEE THIS SHEET FOR DETAILS
1	OEM	CUSTOM INNER DOORS	SEE THIS SHEET FOR DETAILS
1	OEM	BATTERY ENCLOSURE	SEE THIS SHEET FOR DETAILS
2	POWER SONIC	PS-12180 F2	BATTERY, LEAD-ACID, 12VDC, 18Ah
1	RITTAL	4140820	13" 20 LED LIGHT 24VDC
--	--	--	--
1	SIEMENS	52PX8A1K / 52BAK	MOMENTARY PUSHBUTTON, 30mm, FLUSH
1	INGRAM PRODUCTS	LX40F	ALARM LIGHT W/ FLASHER, 120VAC, RED
1	INGRAM PRODUCTS	PW120AR	ALARM HORN, ELECTRONIC, 120VAC, RED
--	--	--	--
1	TIMES-PROTECT	LP-STR-NFF	COAXIAL SURGE ARRESTOR (ANTENNA)
1	SIEMENS	6AV2 124-0GC01-0AX0	OPERATOR PANEL, TP700 COMFORT DISPLAY
1	SIEMENS	6AV2 181-8XP00-0AX0	HMI MEMORY CARD, 2GB
1	OMRON	6X283	SNAP ACTION SWITCH (DOOR AJAR)
1	ALLIED	642-2137	ACTUATOR FOR SWITCH
2	OEM	--	INNER/OUTER DOOR STOP KIT, SS
--	--	--	--
--	--	--	--
2	SIEMENS	52SX2BAB	3 POSITION MAINTAINED SWITCH, 30mm
8	SIEMENS	52BJK	CONTACT BLOCK, 1NO-1NC
1	MENCOM	LP3-GF-2RJ45-R	GFCI RECPT W/ RJ45, 3A

CUSTOM ENCLOSURE:
 48"H x 36"W x 10"D NEMA 12/3R RATED, FABRICATED FROM .125 MARINE GRADE ALUMINUM WITH WHITE POLYESTER POWDER COAT FINISH INSIDE AND OUT. OUTER DOORS ARE FITTED WITH A PADLOCKABLE 3-POINT LATCH AND DOOR STOPS.

HEAT SHIELDS FABRICATED FROM .125 MARINE GRADE ALUMINUM SHALL BE INSTALLED ON FRONT, BACK, TOP, AND SIDES. HOLES SHALL BE CUT IN SHIELD FOR ALARM LIGHT AND HORN. HEAT SHIELDS SHALL ALSO HAVE WHITE POLYESTER POWDER COAT FINISH ON ALL SIDES.

REFER TO "VOLUME III: APPROVED MATERIALS" FOR APPROVED ENCLOSURE MANUFACTURERS.

BATTERY ENCLOSURE:
 8"H x 8"W x 8"D FABRICATED FROM .125 MARINE GRADE ALUMINUM. OUTER DOOR IS FITTED WITH PADLOCKABLE QUARTER-TURN LATCH. TO BE SHIPPED LOOSE AND INSTALLED IN THE FIELD VIA BOLTS.

INNER DOOR VIEW

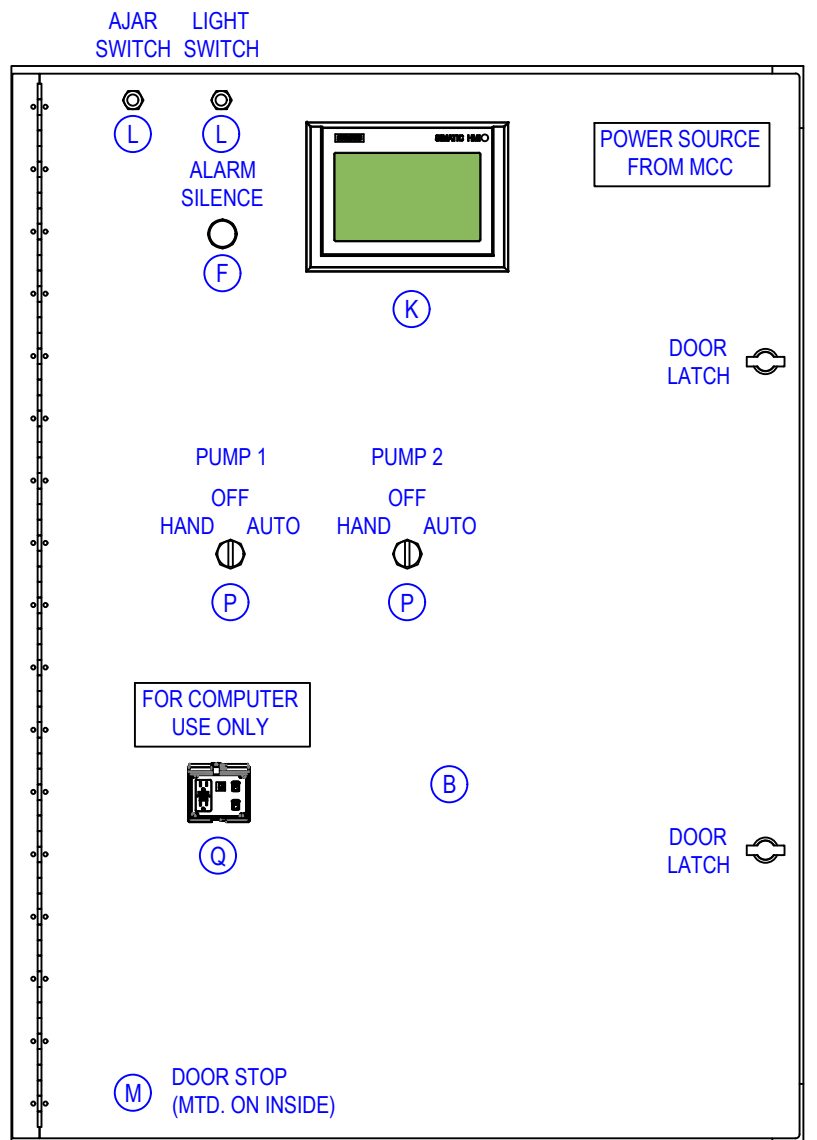

HINGED INNER DOORS:
 FABRICATED FROM .125 ALUMINUM WITH CONTINUOUS HINGE, TWIST LATCHES, AND DOOR STOP MOUNTED ON INSIDE OF EACH.

NO.	BY	DATE	REVISIONS
6.			
5.			
4.			
3.			
2.			
1.			

ELECTRICAL SCHEMATIC

MANUFACTURER
 ADDRESS1
 ADDRESS2
 CONTACT_NAME
 CONTACT_NUMBER



DESIGNER:
 DRAWN BY:
 DATE:
 CHECKED BY:
 DATE:
 2026 STANDARD PACKAGE, REV. 0

SHEET TITLE: SCADA RTU - FRONT VIEW
 PROJECT: --- PROJECT NAME ---
 ACROSS THE LINE LIFT STATION DIAGRAM
 JOB No: 12345678 SHEET 2 OF 14

BACK PANEL LAYOUT

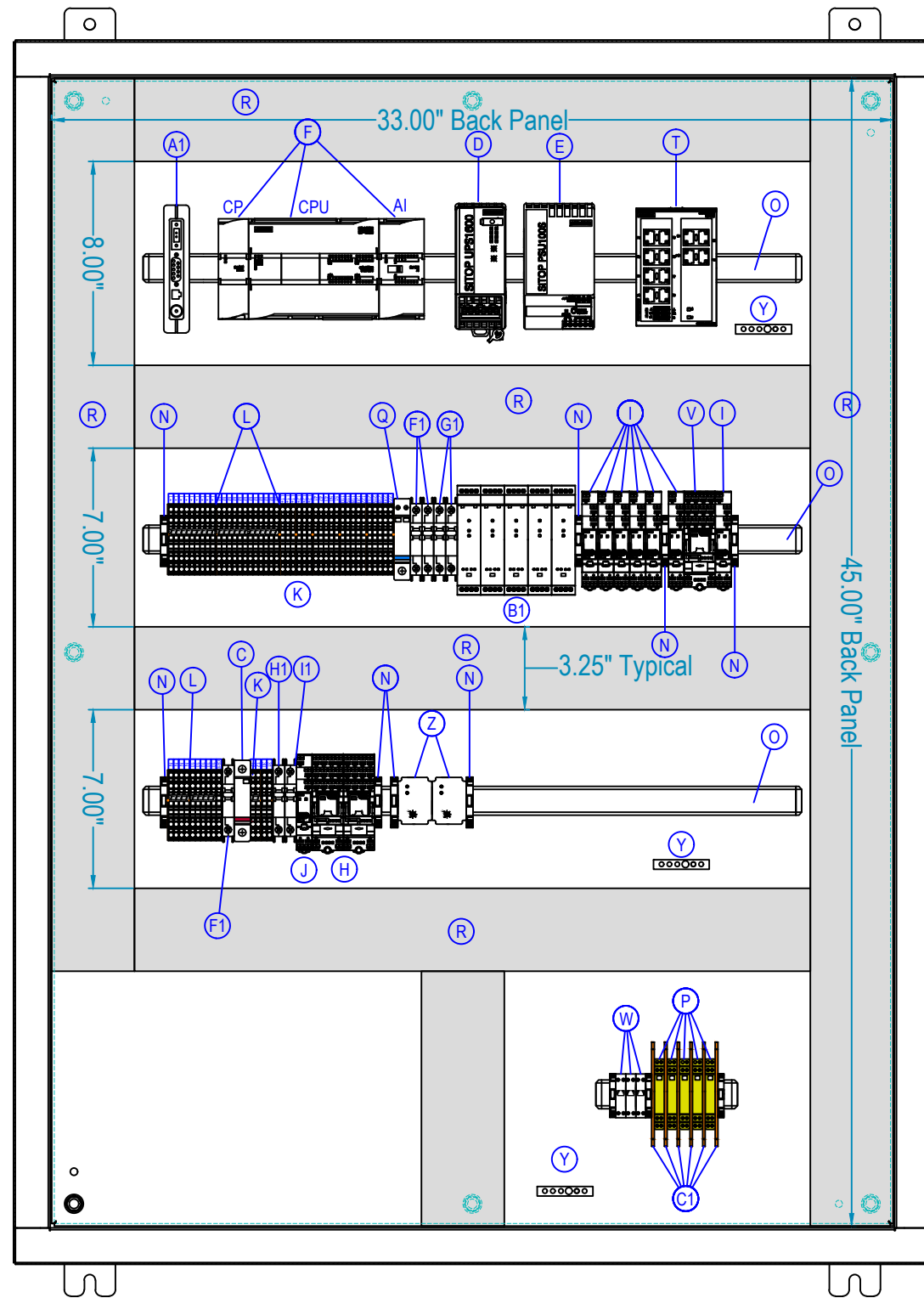

BACK PANEL:
45" H x 33" W. FABRICATED FROM 12ga. CARBON STEEL WITH
WHITE INDUSTRIAL GRADE ENAMEL FINISH.

REFER TO "VOLUME III: APPROVED MATERIALS" FOR
APPROVED ENCLOSURE MANUFACTURERS.

BILL of MATERIAL

QTY	MANUFACTURER	PART NUMBER	DESCRIPTION
A	1	OEM	CUSTOM BACK PANEL
B	--	--	--
C	1	CITEL	DS41S-120
D	1	SIEMENS	6AG113-43AB00-7AY0
E	1	SIEMENS	6AG133-42BA20-4AA0
F	1	SIEMENS	6AG1215-1AG40-4XB0
	1	SIEMENS	6ES795-48LC04-0AA0
	1	SIEMENS	6AG123-14HF32-4XB0
	1	SIEMENS	6AG1241-1AH32-4XB0
	-	SIEMENS	6ES7231-5PA30-0XB0
G	--	--	--
H	2	FINDER	58P481205060
I	7	FINDER	4CP190245050
J	1	FINDER	4CP181205060
K	65	WAGO	2002-1401
L	20	WAGO	2002-1492
M	20	WAGO	2002-400
N	10	WAGO	249-116
O	1	WAGO	210-112
P	5	CITEL	DLAW-24D3
Q	1	CITEL	DS220S-24DC
R	4	PANDUIT	3" W X 3"H X 72" L
S	--	--	--
T	1	SIEMENS	6GK5112-0BA00-2AB2
U	--	--	--
V	1	FINDER	58P490245050
W	3	PHOENIX	2313931
X	--	--	--
Y	2	SIEMENS	ECGB5
Z	2	MACROMATIC	TCP2G100
1	---	---	RADIO, SPREAD-SPECTRUM, UNLICENSED
	---	---	DIN RAIL MOUNT KIT
A1	1	---	RADIO ANTENNA CABLE
B1	5	PR ELECTRONICS	4114
	5	PR ELECTRONICS	4501
C1	5	WAGO	2002-1492
D1	3	SIEMENS	6GK1901-1BB10-2AA0
E1	2	SIEMENS	6XV1840-2AH10
F1	3	SIEMENS	5SJ4110-7HG41
G1	2	SIEMENS	5SJ4103-7HG40
H1	1	SIEMENS	5SJ4105-7HG40
I1	1	SIEMENS	5SJ4102-7HG40

NO.	BY	DATE	REVISIONS
6.			
5.			
4.			
3.			
2.			
1.			

ELECTRICAL SCHEMATIC

MANUFACTURER
ADDRESS1
ADDRESS2

CONTACT_NAME
CONTACT_NUMBER



DESIGNER:
DRAWN BY:
DATE:
CHECKED BY:
DATE:
2026 STANDARD PACKAGE, REV. 0

SHEET TITLE: SCADA RTU - BACK PANEL LAYOUT	
PROJECT: --- PROJECT NAME ---	
ACROSS THE LINE LIFT STATION DIAGRAM	
JOB No: 12345678	SHEET 3 OF 14

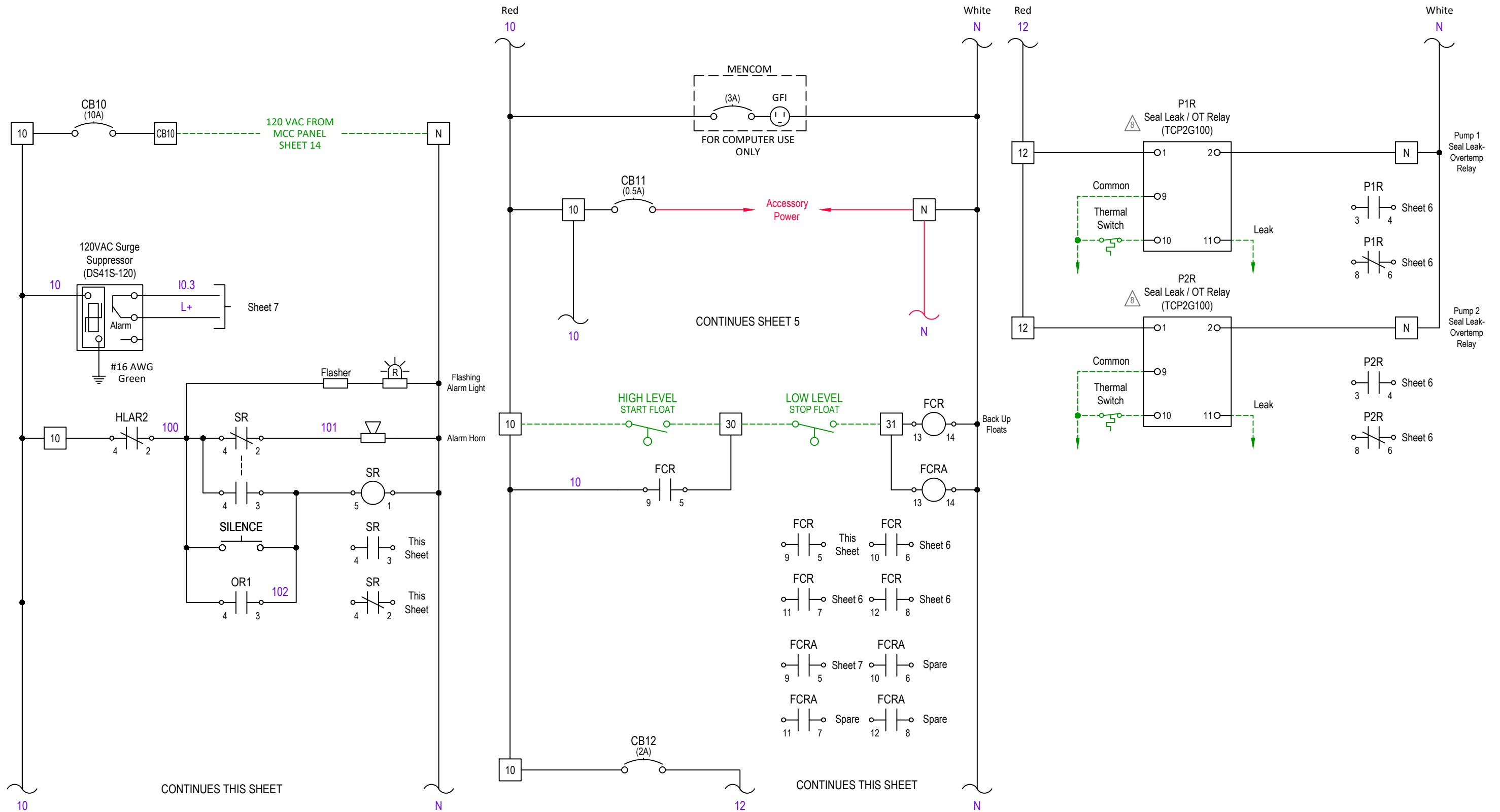

NO.	BY	DATE	REVISIONS
6.			
5.			
4.			
3.			
2.			
1.			

ELECTRICAL SCHEMATIC

MANUFACTURER
 ADDRESS1
 ADDRESS2
 CONTACT_NAME
 CONTACT_NUMBER



DESIGNER:
 DRAWN BY:
 DATE:
 CHECKED BY:
 DATE:
 2026 STANDARD PACKAGE, REV. 0

SHEET TITLE:
SCADA RTU - 120 VAC VOLTAGE
 PROJECT:
 --- PROJECT NAME ---
ACROSS THE LINE LIFT STATION DIAGRAM
 JOB No: 12345678 SHEET 4 OF 14

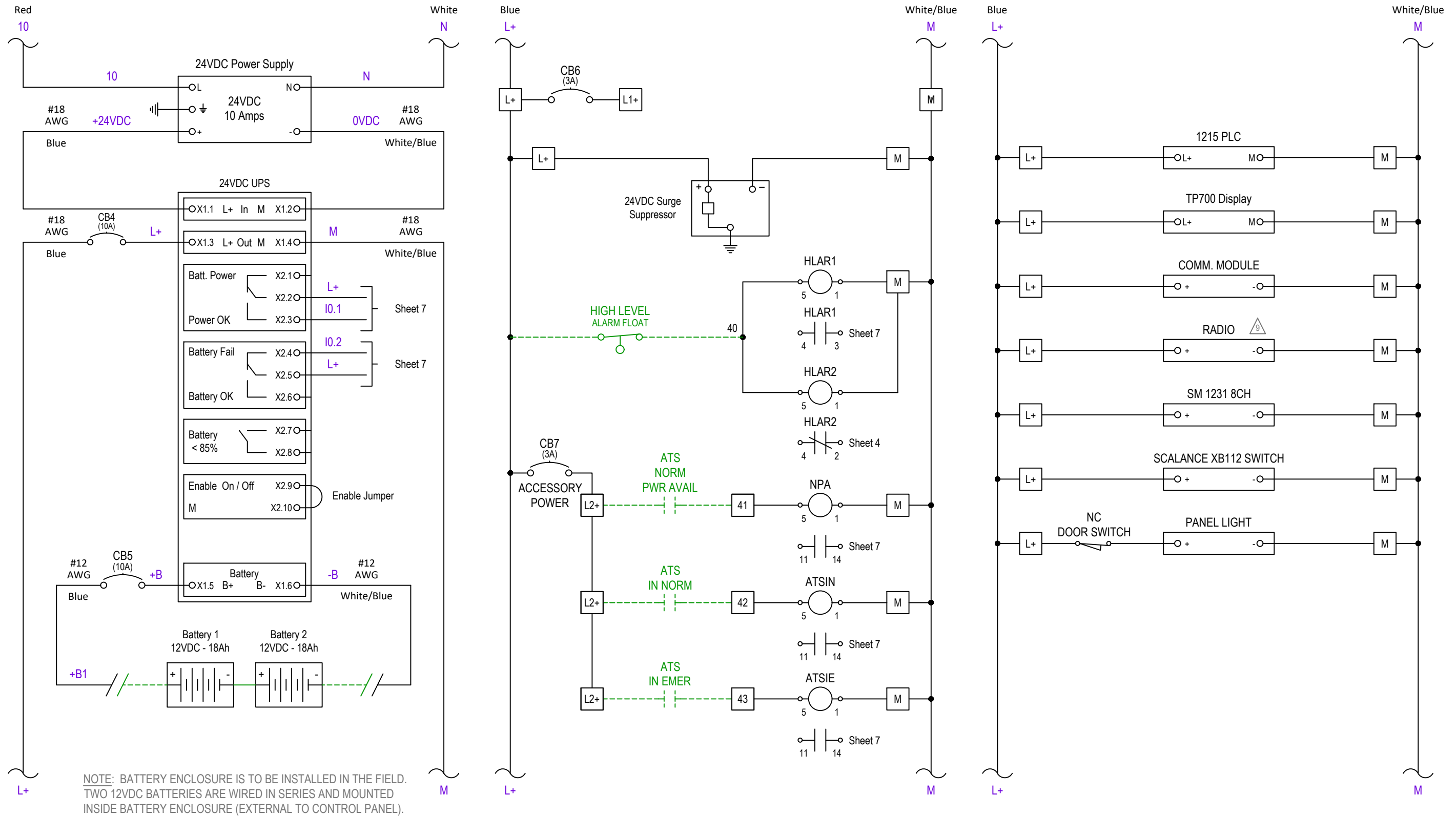

NO.	BY	DATE	REVISIONS
6.			
5.			
4.			
3.			
2.			
1.			

ELECTRICAL SCHEMATIC

MANUFACTURER
ADDRESS1
ADDRESS2
CONTACT_NAME
CONTACT_NUMBER



DESIGNER:
DRAWN BY:
DATE:
CHECKED BY:
DATE:
2026 STANDARD PACKAGE, REV. 0

SHEET TITLE:
SCADA RTU - 24 VDC VOLTAGE
PROJECT:
--- PROJECT NAME ---
ACROSS THE LINE LIFT STATION DIAGRAM
JOB No: 12345678 SHEET 5 OF 14

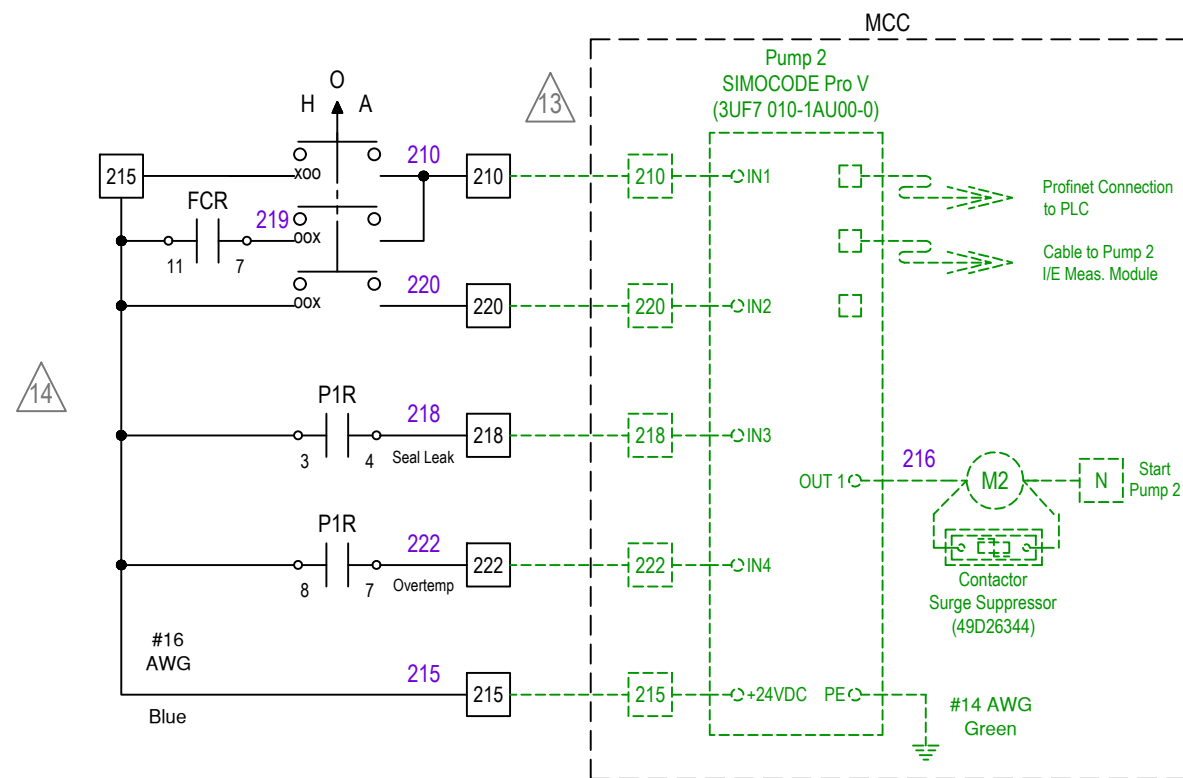
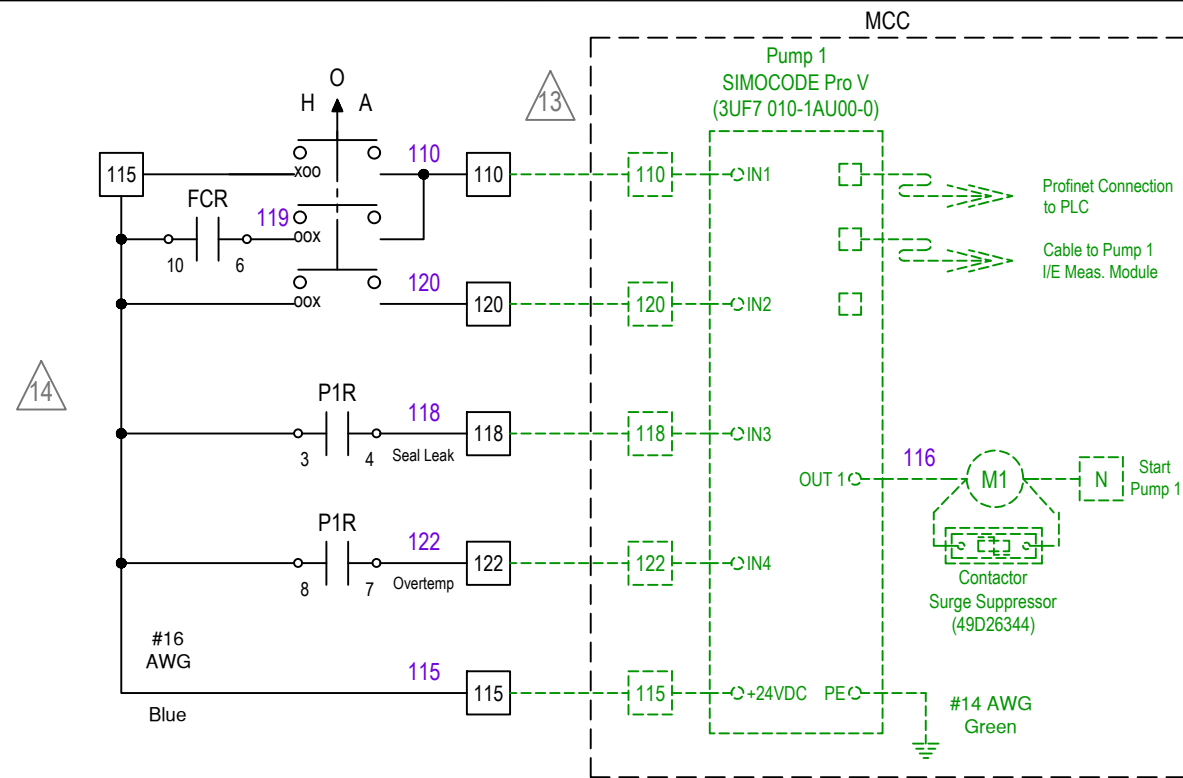

NO.	BY	DATE	REVISIONS
6.			
5.			
4.			
3.			
2.			
1.			

ELECTRICAL SCHEMATIC

MANUFACTURER
ADDRESS1
ADDRESS2
CONTACT_NAME
CONTACT_NUMBER



DESIGNER:
DRAWN BY:
DATE:
CHECKED BY:
DATE:
2026 STANDARD PACKAGE, REV. 0

SHEET TITLE:
SCADA RTU - SIMOCODE CONTROL WIRING
PROJECT:
--- PROJECT NAME ---
ACROSS THE LINE LIFT STATION DIAGRAM
JOB No: 12345678 SHEET 6 OF 14

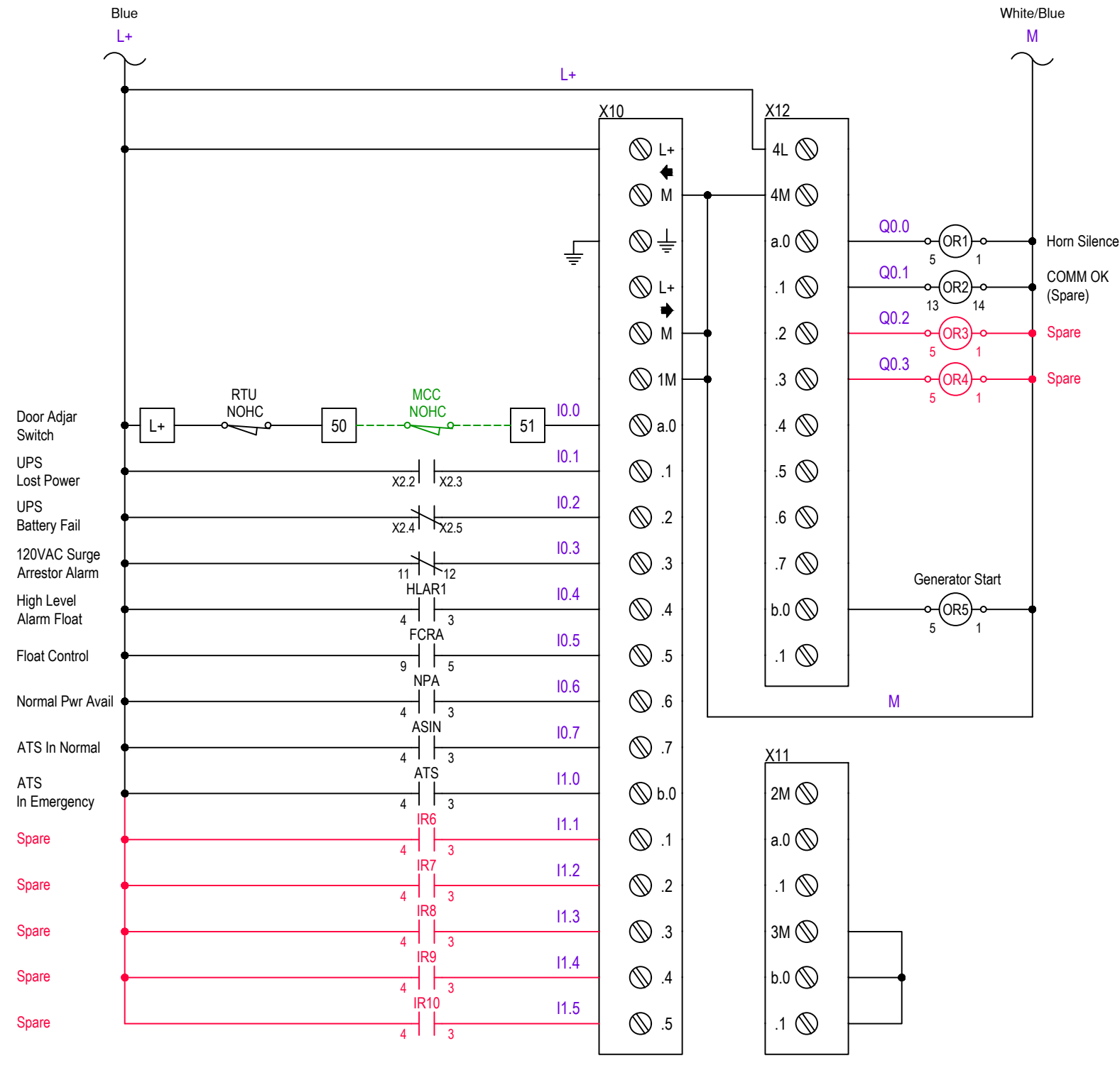

6AG1 215-1AG40-4XB0	
14 Digital Input	
10 Digital Output	
L+	L+ = +24V
M	M = DC COM
GND	GND
L+	
M	M = DC COM
1M	1M = DC COM
a.0	Input 0.0
.1	Input 0.1
.2	Input 0.2
.3	Input 0.3
.4	Input 0.4
.5	Input 0.5
.6	Input 0.6
.7	Input 0.7
b.0	Input 1.0
.1	Input 1.1
.2	Input 1.2
.3	Input 1.3
.4	Input 1.4
.5	Input 1.5
4L	4L = +24V
4M	4M = DC COM
a.0	Output 0.0
.1	Output 0.1
.2	Output 0.2
.3	Output 0.3
.4	Output 0.4
.5	Output 0.5
.6	Output 0.6
.7	Output 0.7
b.0	Output 1.0
b.1	Output 1.1
2M	2M = DC COM
a.0	Output 0.0
.1	Output 0.1
3M	3M = DC COM
b.0	Input 0.0
b.1	Input 0.1

NO.	BY	DATE	REVISIONS
6.			
5.			
4.			
3.			
2.			
1.			

ELECTRICAL SCHEMATIC

MANUFACTURER
ADDRESS1
ADDRESS2

CONTACT_NAME
CONTACT_NUMBER



DESIGNER:
DRAWN BY:
DATE:
CHECKED BY:
DATE:
2026 STANDARD PACKAGE, REV. 0

SHEET TITLE:
SCADA RTU - PLC DIGITAL I/O

PROJECT:
--- PROJECT NAME ---

ACROSS THE LINE LIFT STATION DIAGRAM

JOB No: **12345678** SHEET **7** OF **14**

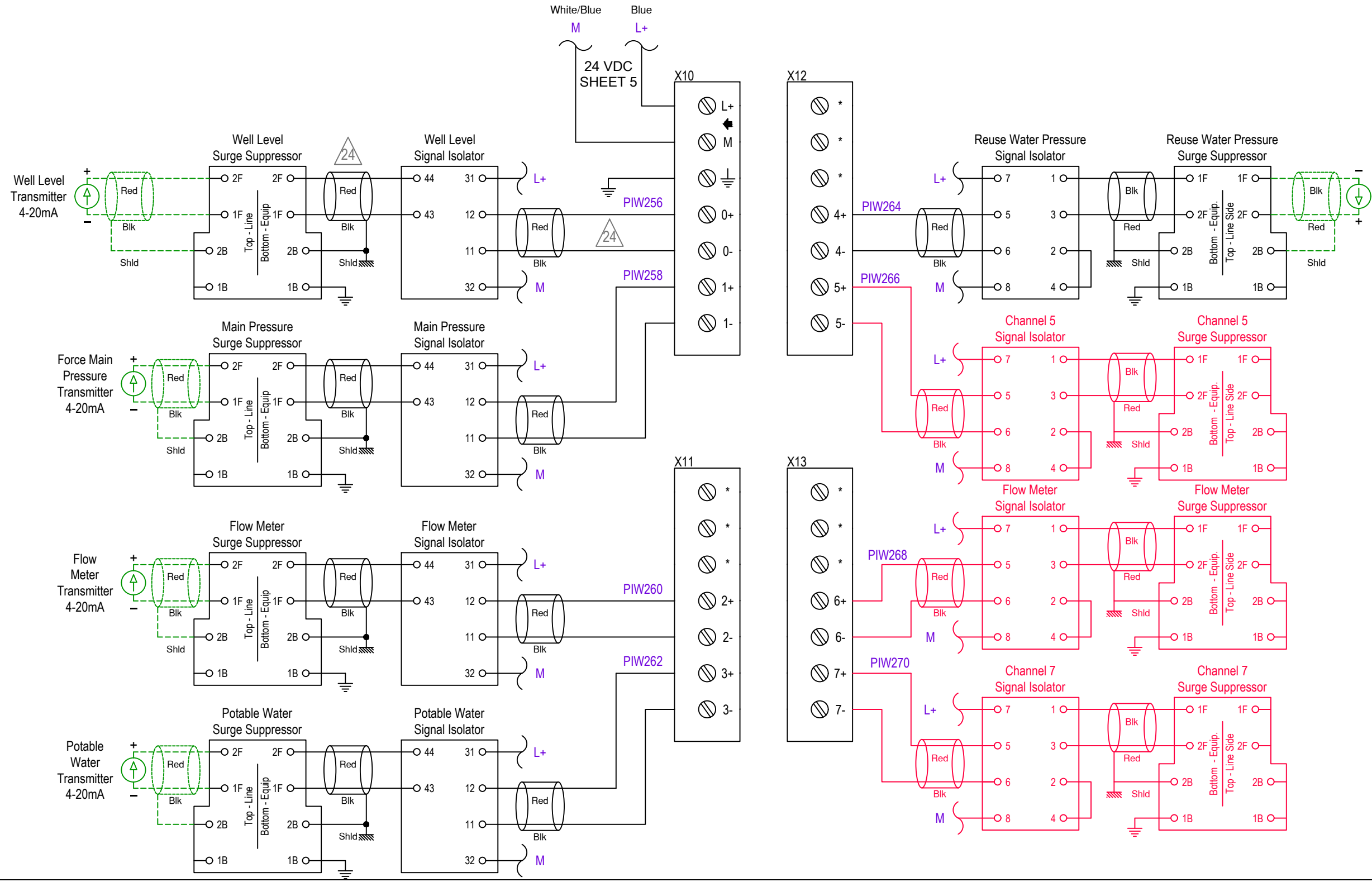

6AG1 231-4HF32-4XB0	
8 Analog Input	
L+	L+ = +24V
M	M = DC COM
GND	GND
0+	CH0 + => PIW256
0-	CH0 -
1+	CH1 + => PIW258
1-	CH1 -
*	
*	
*	
2+	CH2 + => PIW260
2-	CH2 -
3+	CH3 + => PIW262
3-	CH3 -
*	
*	
*	
4+	CH4 + => PIW264
4-	CH4 -
5+	CH5 + => PIW266
5-	CH5 -
*	
*	
6+	CH6 + => PIW268
6-	CH6 -
7+	CH7 + => PIW270
7-	CH7 -

NO.	BY	DATE	REVISIONS
6.			
5.			
4.			
3.			
2.			
1.			

ELECTRICAL SCHEMATIC

MANUFACTURER
ADDRESS1
ADDRESS2

CONTACT_NAME
CONTACT_NUMBER



DESIGNER:
DRAWN BY:
DATE:
CHECKED BY:
DATE:
2026 STANDARD PACKAGE, REV. 0

SHEET TITLE:
SCADA RTU - PLC ANALOG INPUT

PROJECT:
--- PROJECT NAME ---

ACROSS THE LINE LIFT STATION DIAGRAM

JOB No: 12345678 SHEET 8 OF 14

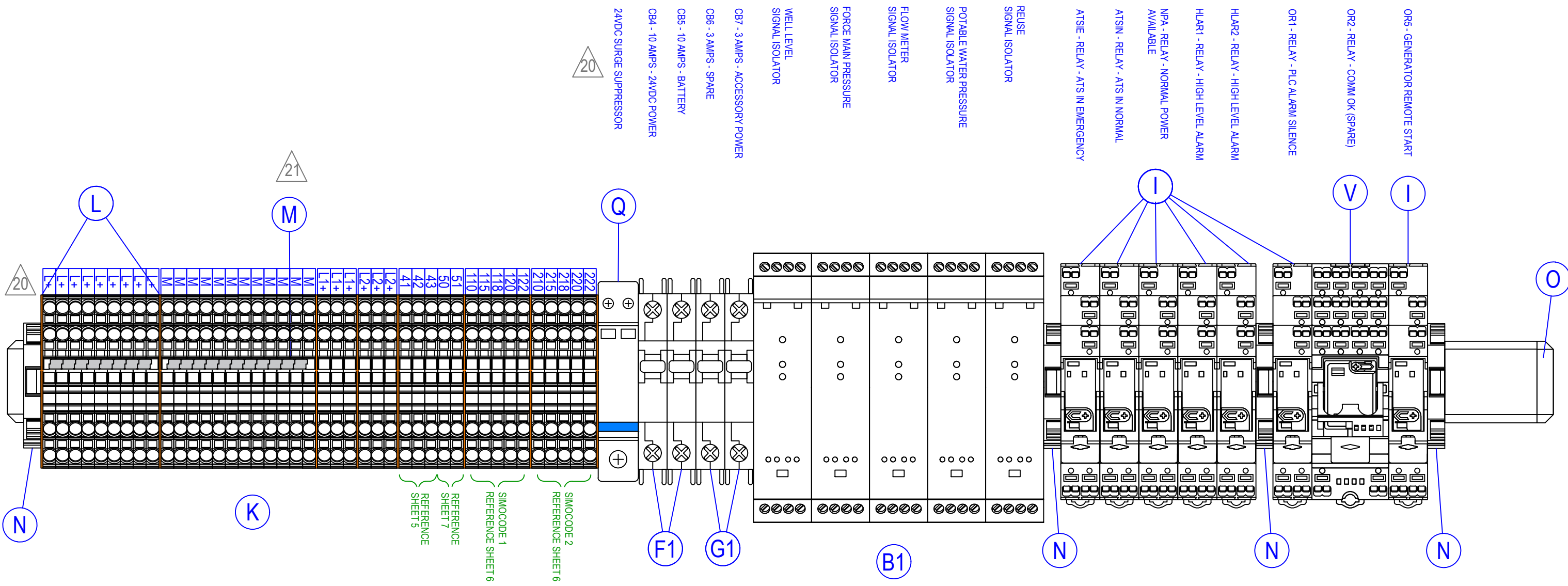

NO.	BY	DATE	REVISIONS
6.			
5.			
4.			
3.			
2.			
1.			

ELECTRICAL SCHEMATIC

MANUFACTURER
ADDRESS1
ADDRESS2

CONTACT_NAME
CONTACT_NUMBER



DESIGNER:
DRAWN BY:
DATE:
CHECKED BY:
DATE:
2026 STANDARD PACKAGE, REV. 0

SHEET TITLE:
CONTROL PANEL - 24 VDC TERMINAL BLOCK LAYOUT

PROJECT:
--- PROJECT NAME ---

ACROSS THE LINE LIFT STATION DIAGRAM

JOB No: **12345678** SHEET **10** OF **14**

- REUSE WATER PRESS XMITTER SURGE SUPPRESSOR
- POTABLE WATER PRESSURE XMITTER SURGE SUPPRESSOR
- FLOW METER SURGE SUPPRESSOR
- MAIN PRESSURE XMITTER SURGE SUPPRESSOR
- WELL LEVEL SURGE SUPPRESSOR
- GENERATOR PROFINET NETWORK ISOLATOR
- PONY PUMP PROFINET NETWORK ISOLATOR
- FLOW METER PROFINET NETWORK ISOLATOR

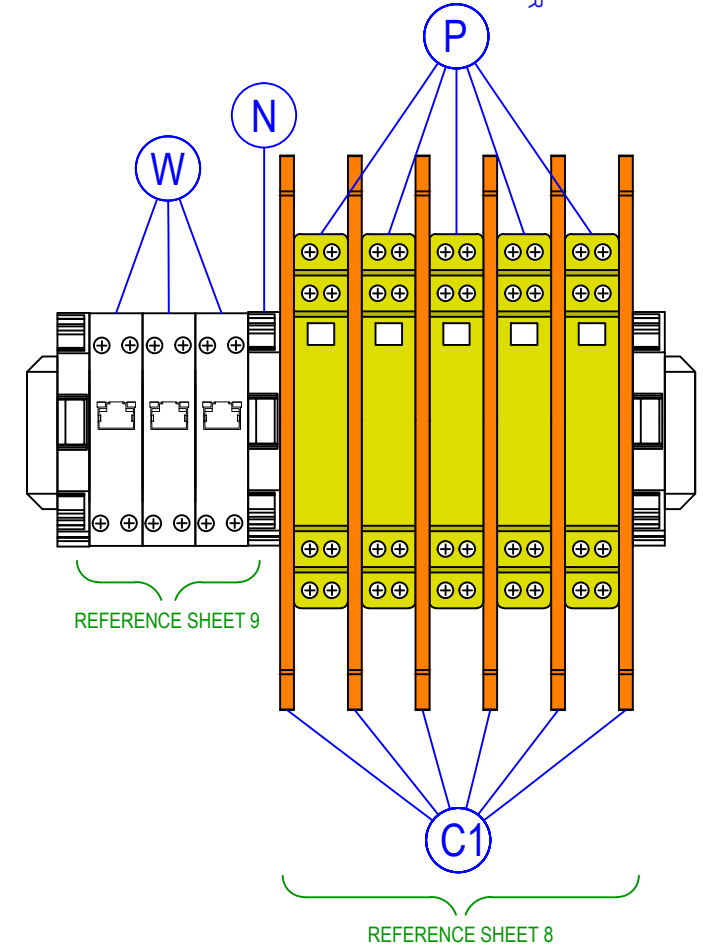

- P2R - PUMP 2
- P1R - PUMP 1



REFERENCE SHEET 4

- FCRA - RELAY - FLOAT CONTROL
- FCR - RELAY - FLOAT CONTROL
- SR - RELAY - ALARM SILENCE
- CB12 - 2 AMPS - FIELD DEVICES
- CB11 - 0.5 AMPS - ACCESSORY POWER
- 120VAC SURGE SUPPRESSOR
- CB10 - 10 AMPS - CONTROL PANEL POWER

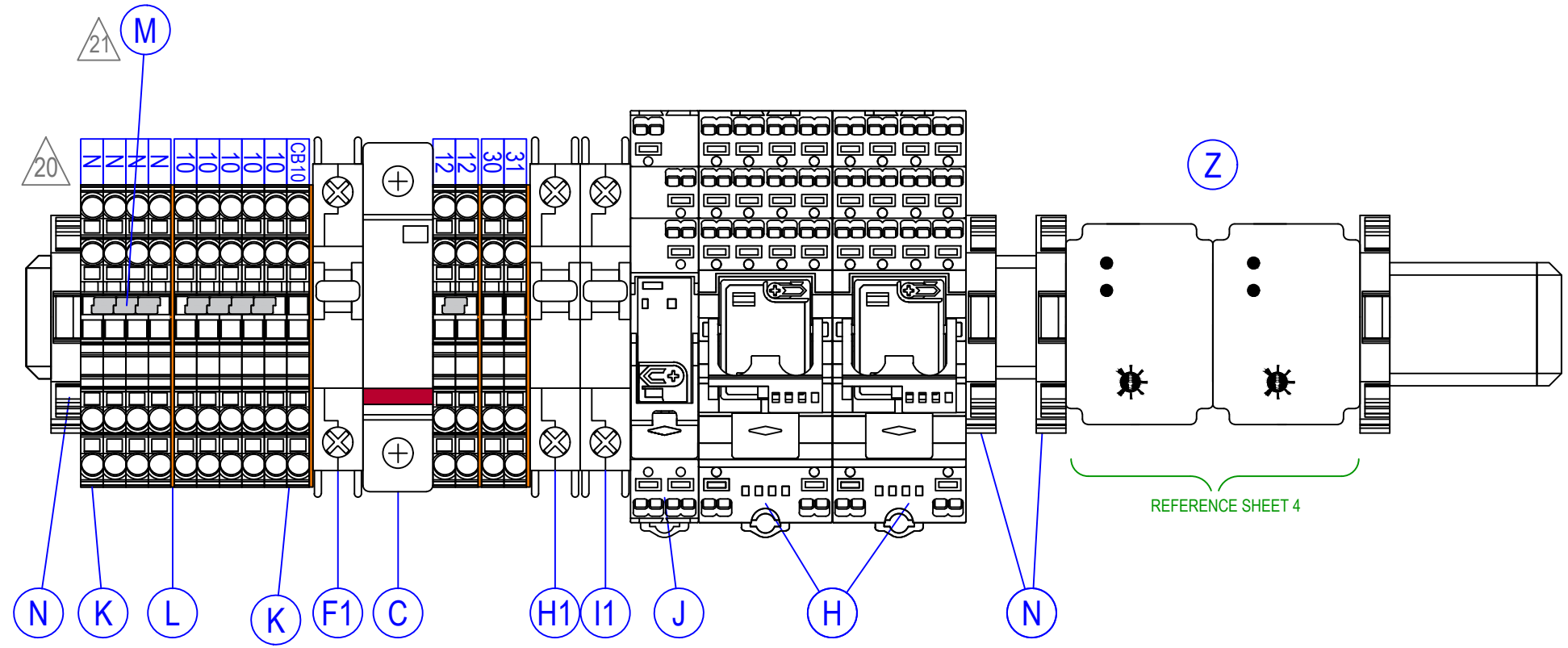

NO.	BY	DATE	REVISIONS
6.			
5.			
4.			
3.			
2.			
1.			

ELECTRICAL SCHEMATIC

MANUFACTURER
ADDRESS1
ADDRESS2

CONTACT_NAME
CONTACT_NUMBER



DESIGNER:
DRAWN BY:
DATE:
CHECKED BY:
DATE:
2026 STANDARD PACKAGE, REV. 0

SHEET TITLE:
SCADA RTU - 120 VAC TERMINAL BLOCK LAYOUT

PROJECT:
--- PROJECT NAME ---

ACROSS THE LINE LIFT STATION DIAGRAM

JOB No: 12345678

SHEET 11 OF 14

FRONT VIEW

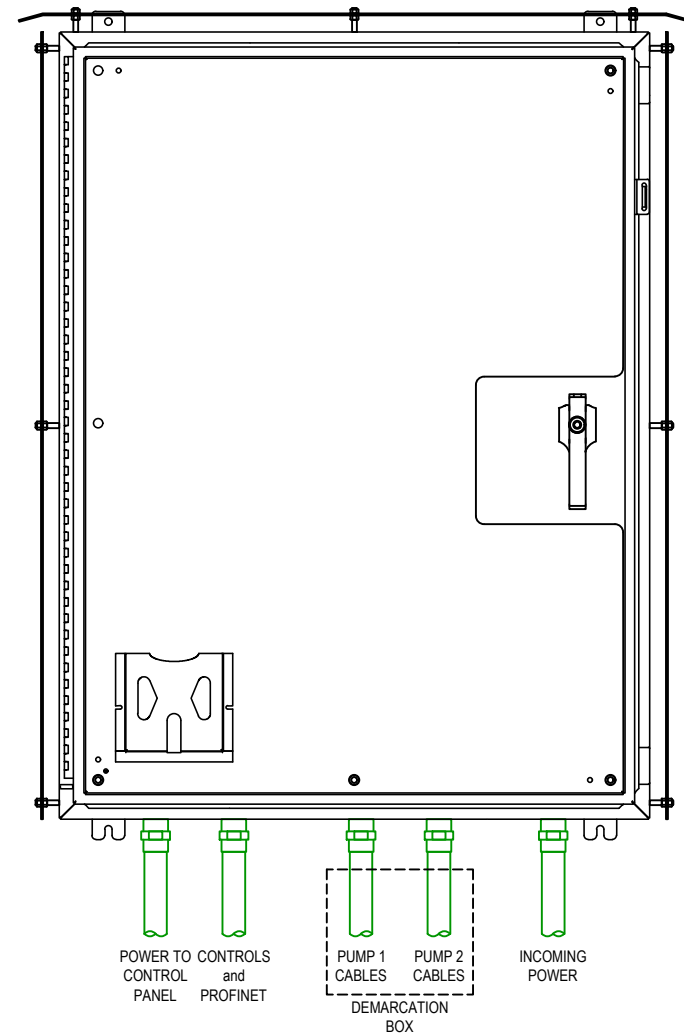

BILL of MATERIAL				
	QTY	MANUFACTURER	PART NUMBER	DESCRIPTION
⚠	A	1	OEM	CUSTOM ENCLOSURE SEE THIS SHEET FOR DETAILS
⚠	B	1	OEM	CUSTOM INNER DOORS SEE THIS SHEET FOR DETAILS
	C	--	--	--
	D	--	--	--
	E	--	--	--
⚠	F	1	APT	S50A240V3H SURGE PROTECTOR, 240V DELTA HI-LEG
			APT	S50A277V3Y SURGE PROTECTOR, 480V WYE
	G	2	OMRON	6X283 SNAP ACTION SWITCH (DOOR AJAR)
		2	ALLIED	642-2137 ACTUATOR FOR SWITCH
	H	2	OEM	-- INNER/OUTER DOOR STOP KIT, SS
	I	--	--	--
	J	--	--	--



INNER DOOR VIEW

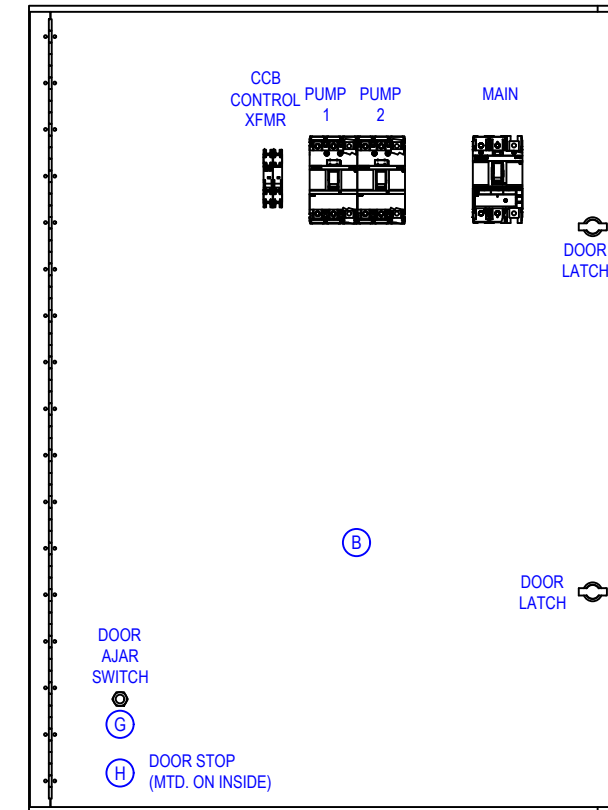

HINGED INNER DOORS:
FABRICATED FROM .125 ALUMINUM WITH CONTINUOUS HINGE, TWIST LATCHES, AND DOOR STOP MOUNTED ON INSIDE OF EACH.

CUSTOM ENCLOSURE:
48"H x 36"W x 10"D NEMA 12/3R RATED, FABRICATED FROM .125 MARINE GRADE ALUMINUM WITH WHITE POLYESTER POWDER COAT FINISH INSIDE AND OUT. OUTER DOORS ARE FITTED WITH A PADLOCKABLE 3-POINT LATCH AND DOOR STOPS.

HEAT SHIELDS FABRICATED FROM .125 MARINE GRADE ALUMINUM SHALL BE INSTALLED ON FRONT, BACK, TOP, AND SIDES. HOLES SHALL BE CUT IN SHIELD FOR ALARM LIGHT AND HORN. HEAT SHIELDS SHALL ALSO HAVE WHITE POLYESTER POWDER COAT FINISH ON ALL SIDES.

REFER TO "VOLUME III: APPROVED MATERIALS" FOR APPROVED ENCLOSURE MANUFACTURERS.

NO.	BY	DATE	REVISIONS
6.			
5.			
4.			
3.			
2.			
1.			

ELECTRICAL SCHEMATIC

MANUFACTURER
ADDRESS1
ADDRESS2

CONTACT_NAME
CONTACT_NUMBER



DESIGNER:
DRAWN BY:
DATE:
CHECKED BY:
DATE:
2026 STANDARD PACKAGE, REV. 0

SHEET TITLE: MCC - FRONT PANEL VIEW	
PROJECT: --- PROJECT NAME ---	
ACROSS THE LINE LIFT STATION DIAGRAM	
JOB No: 12345678	SHEET OF 12 OF 14

BACK PANEL LAYOUT

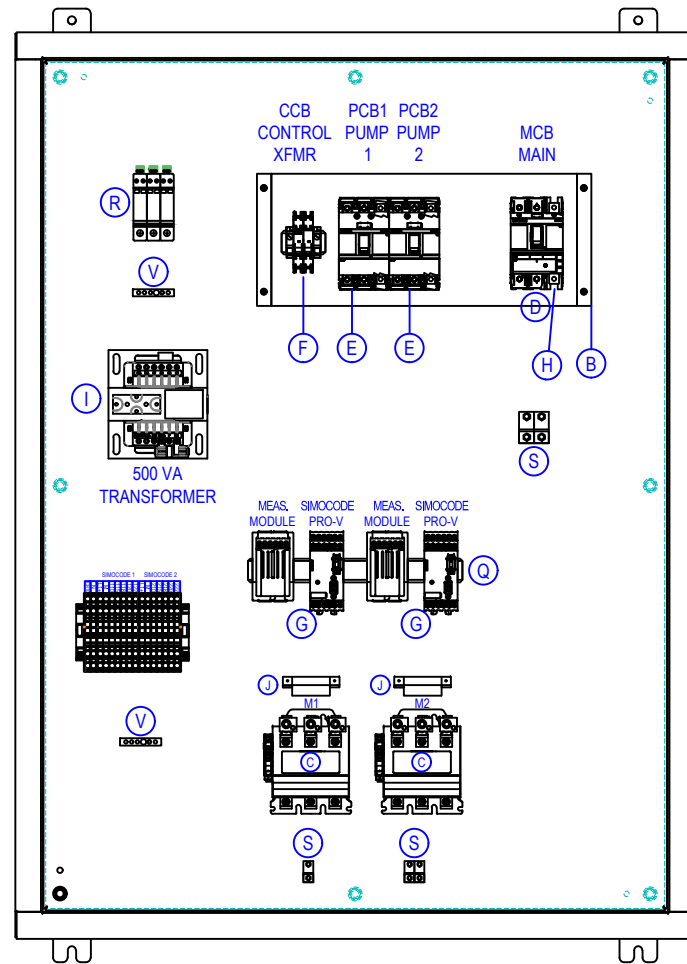

BACK PANEL:
45" H x 33" W. FABRICATED FROM 12ga. CARBON STEEL WITH WHITE INDUSTRIAL GRADE ENAMEL FINISH.

REFER TO "VOLUME III: APPROVED MATERIALS" FOR APPROVED ENCLOSURE MANUFACTURERS.

BILL of MATERIAL

	QTY	MANUFACTURER	PART NUMBER	DESCRIPTION	
△	A	1	OEM	CUSTOM BACK PANEL	SEE THIS SHEET FOR DETAILS
△	B	1	OEM	BREAKER MOUNT	TO RAISE CBs FLUSH WITH INNER DOOR
△	C	2	SIEMENS	40HP32A	FVNR CONTACTOR, 3 POLE, NEMA 3
△	D	1	SIEMENS	3VA5220-5ED31-0AA0	MCB, 3P, 200A
△	E	2	SIEMENS	3VA5120-5ED31-0AA0	PCB1 AND PCB2, 3P, 20A
△	F	1	SIEMENS	5SJ4206-7HG41	CCB, 2P, 6A, 240V
△		1	SIEMENS	5SJ4203-7HG42	CCB, 2P, 3A, 480V
△	G	2	SIEMENS	3UF7 011-1AU00-0	SIMOCODE PRO V BASE UNIT, PN, 120VAC
△		2	SIEMENS	3UF7 112-1AA01-0	SIMOCODE PRO I/E MEAS. MODULE (100A)
△		2	SIEMENS	3UF7 935-0AA00-0	SIMOCODE CABLE, 0.3M
	H	1	SIEMENS	3TA6FG04	POWER DISTRIBUTION LUGS, KIT OF 3
	I	1	SIEMENS	MT0500A	CONTROL TRANSFORMER, 500VA
△	J	2	SIEMENS	49D26344	CONTACTOR SURGE SUPPRESSOR
	K	--	--	--	--
	L	--	--	--	--
	M	16	WAGO	2002-1401	TERMINAL, 2002, SPRING, GRAY
	N	5	WAGO	2002-1492	TERMINAL END / PART. PLATE, ORANGE
	O	-	WAGO	2002-400	ADJACENT JUMPER, 2-WAY CONTINUOUS
	P	10	WAGO	249-116	TERMINAL END STOP, GRAY
	Q	1	WAGO	210-112	2M DIN RAIL, GALVANIZED, SLOTTED
△	R	1	CITEL	DS43S-400	PRIMARY SPD, TYPE 1, 240V DELTA HI-LEG
△		1	CITEL	DS43S-480	PRIMARY SPD, TYPE 1, 480V WYE
	S	9	PANDUIT	LAMA2-14-QY	GROUND LUG, DUAL-RATED, #2-14AWG
	T	--	--	--	--
	U	-	PANDUIT	1.5"W x 3"H x 72"L	WIREWAY, HINGE COVER, WIDE FINGER
△	V	2	SIEMENS	ECGB5	EQUIPMENT GROUND BAR, 5-POINT
	W	--	--	--	--
	X	3	SIEMENS	6GK1901-1BB10-2AA0	PROFINET CONNECTOR, SIPLUS
	Y	2	SIEMENS	6XV1840-2AH10	PROFINET CABLE, FAST CONNECT
	Z	--	--	--	--

TERMINAL STRIP DETAIL

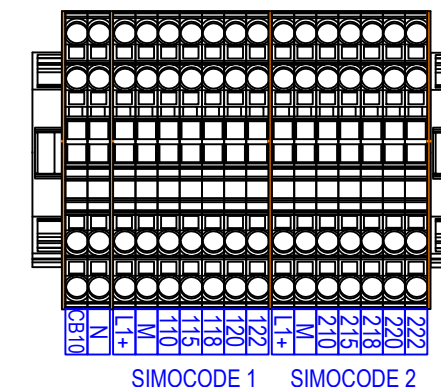

REFERENCE SHEET 6

NO.	BY	DATE	REVISIONS	ELECTRICAL SCHEMATIC	DESIGNER:	SHEET TITLE:	
6.				MANUFACTURER ADDRESS1 ADDRESS2 CONTACT_NAME CONTACT_NUMBER		MCC - BACK PANEL LAYOUT	
5.						PROJECT:	
4.						---	
3.						ACROSS THE LINE LIFT STATION DIAGRAM	
2.						JOB No:	
1.						12345678	
						2026 STANDARD PACKAGE, REV. 0	SHEET 13 OF 14



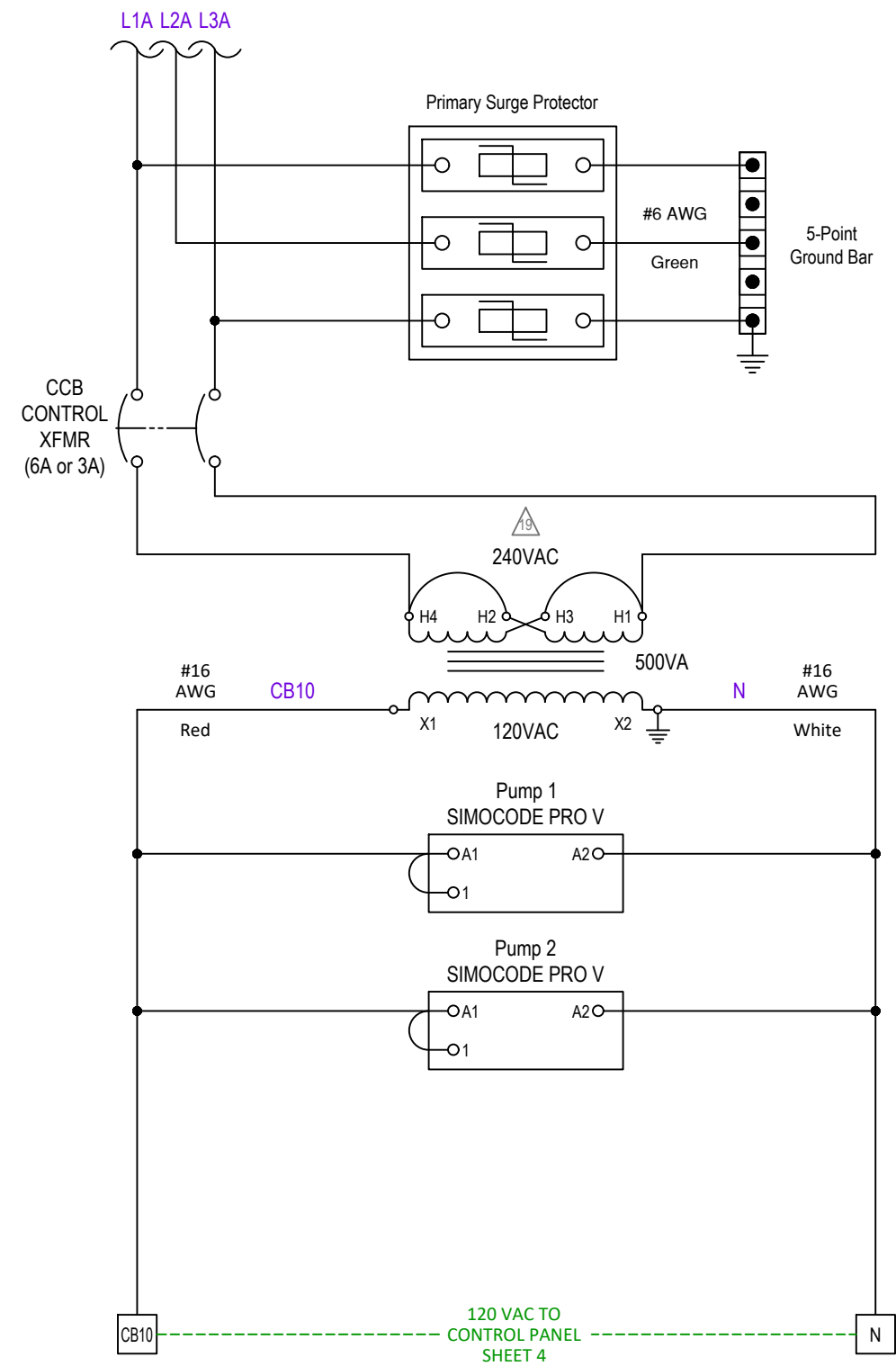
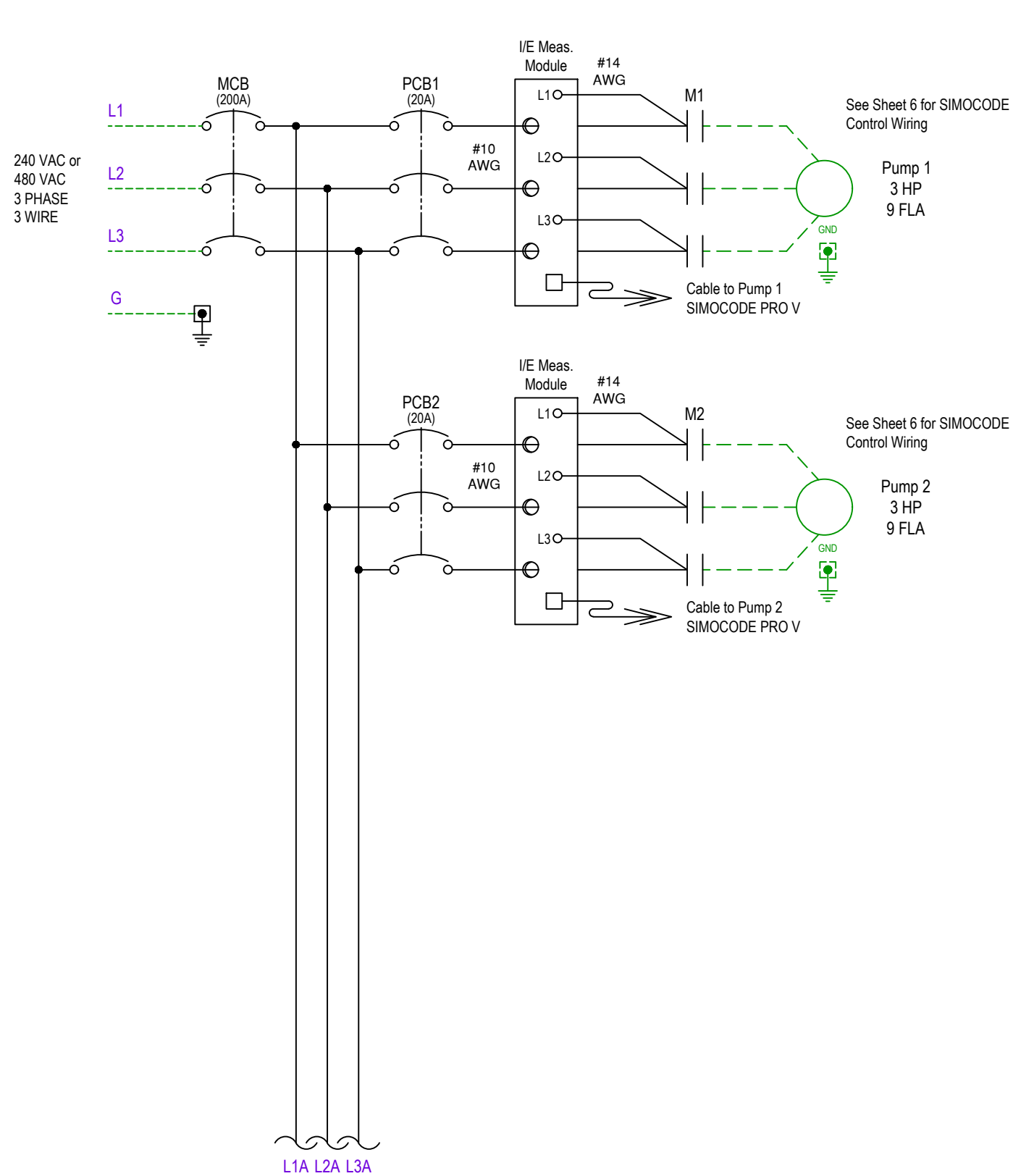

NO.	BY	DATE	REVISIONS
6.			
5.			
4.			
3.			
2.			
1.			

ELECTRICAL SCHEMATIC

MANUFACTURER
ADDRESS1
ADDRESS2
CONTACT_NAME
CONTACT_NUMBER



DESIGNER:
DRAWN BY:
DATE:
CHECKED BY:
DATE:
2026 STANDARD PACKAGE, REV. 0

SHEET TITLE:
MCC - PANEL MAIN VAC VOLTAGE
PROJECT:
--- PROJECT NAME ---
ACROSS THE LINE LIFT STATION DIAGRAM
JOB No: 12345678 SHEET 14 OF 14