

HORIZONTAL BORING

I. GENERAL

- I.1. Driven or bored casing pipe provides an effective housing for duct. Its use is required in situations where open cutting is not permitted such as crossings under railroads and heavily traveled highways.
- I.2. Horizontal borings under railroads shall be done in accordance with the requirements of the particular railroad involved.
- I.3. Borings under state roads shall be accomplished in accordance with the FDOT Utility Accommodation Guide.

II. METHOD

Jacking and receiving pits shall be constructed at the termination of the crossing. Steel casing is then installed between the pits by machine boring and jacking.

III. PROCEDURE

- III.1. A permit from the appropriate source shall be obtained by the JEA prior to beginning construction.
 - III.1.1. Subsurface Soil and Drainage Investigation:

To correctly plan crossing procedures such as dewatering, use of cutting heads, positioning of auger within the casing, and to accurately locate potential problem areas, an adequate subsurface investigation shall be made. A report of such investigation is required for a DOT Permit and will be made by JEA.
 - III.1.2. Dewatering:

Where the ground water level is above the invert of the proposed level must be designed, installed and in operation prior to beginning the crossing. The DOT requires, when dewatering is necessary, that a written plan showing the proposed method be included with the subsurface investigation report.
 - III.1.3. Jacking Pits:
 - III.1.3.1. Excavated areas from which jacking and receiving operations are accomplished. Jacking pits shall be located at a distance from the roadbed as specified by the appropriate permit. The pit dimensions shall be large enough to provide a safe, adequate working area.
 - III.1.3.2. Walls shall be sloped or supported in accordance with OSHA construction requirements. Where necessary to insure a solid, stable base for boring machinery, some means of stabilizing the pit floor must be provided.
 - III.1.4. Equipment Set-Up:

To properly control line and grade, it is imperative that the jacking tracks be rigidly set to the predetermined level and alignment requirements. Control shall be insured by the use of appropriate engineering instruments.

IV. CROSSING OPERATION

- IV.1. Determination and preparations for the following shall be accomplished prior to the commencement of the operation:
 - IV.1.1. Auger and casing lengths.
 - IV.1.2. Methods of reducing skin friction.
 - IV.1.3. Relationship between auger or cutting head to leading end of first casing section.
 - IV.1.4. Auger size and spacing.
 - IV.1.5. The use of steel shelving in the leading end of the casing to prevent undue flowback of spoil material.
 - IV.1.6. The use of drilling fluid.
 - IV.1.7. Traffic control.
- IV.2. The operation, once started, shall be continued until completed. The crossing shall be accomplished during daylight hours and shall not begin after the hour pre-established as the latest starting time.
- IV.3. If forward motion of the casing is halted at any time other than for reasons planned for in advance (addition of casing and auger sections, etc.) and prevention of voids under roadbed cannot be assured, the casing must be filled with concrete by pressure grouting as soon as possible and abandoned. If removal of the augers in the casing will allow voids to form at the casing head, the augers must be abandoned also.

V. MULTIPLE DUCT IN CASINGS

- V.1. GENERAL:

Ducts to be installed in a casing shall be supported by circular plastic spacers. The void between the ducts and the casing will be filled with a concrete based material to provide a thermal path for the dissipation of heat.
- V.2. MATERIAL:
 - V.2.1. Duct:
 - V.2.1.1. Fiberglass reinforced epoxy duct shall be used. This type duct is specified because of its compressive strength to preclude collapse during grouting operations, its high stiffness properties which enables the use of fewer spacers, its low co-efficient of friction which enables longer cable-pulls, its resistance to deformation when overheated, its resistance to cable fusion when shorted, and its thermal expansion which is about the same as concrete.
 - V.2.1.2. Duct joints shall be specified which make the duct water tight and prevent pressurized grout from entering the duct during construction.
 - V.2.2. 5.2.2. Bore Spacers:

High-Density polyethylene spacers providing 1-1/2" spacing between ducts shall be used. They shall be designed with extra openings to permit easy flow of grout and to allow threading or wire guides.

TYPICAL BORE SPACER CHART

		Casing Diameter (OD)											
		14"	16"	18"	20"	22"	24"	26"	28"	30"	32"	34"	36"
Duct Size	4"	2	3	5	7	7	9	11	15	16	16	19	22
	6"	--	--	2	4	4	5	5	7	8	8	9	11
		Duct Per Casing											

NOTE: Spacers will be installed at a maximum of 10' on centers.

V.3. GROUT:

The grout used to fill the voids is an important consideration as it must fill completely. A regular cement grout is the least desirable as it is normally difficult to pump without leaving voids unless it is very fluid. Additives (such as "Elastizell" or "Mearicrete") which reduce the grout density to about 75 pounds per cubic foot and increase fluidity similar to that of an 11 inch slump allow for lower pumping pressures.

VI. INSTALLATION

VI.1. DUCT INSTALLATION:

Parallel 1/2" diameter wire rope is installed in the casing from the receiving pit to the jacking pit. The wire ropes are threaded through the spacers as the conduit is assembled into the spacers in the jacking pit. As the conduit is assembled it is slid into the casing. If necessary, spacers with rollers are available to facilitate the sliding of the conduit assembly into the casing. The purpose of the wire ropes is to prevent the ducts from skewing and getting out of position within the casing.

VI.2. GROUT INSTALLATION:

The low end of the casing is blocked off except for an air vent at the top of the casing. The higher end of the casing is blocked off except to allow space for the pumping hose. Grout is then pumped until the casing is full and no voids remain.

VII. ADDITIONAL PLATES

VII.1. Listed below are plates not otherwise covered by a Construction Standard Plate and Drawing.

VII.1.1. BORE-JACK* plates include all required equipment, and labor to install duct.

PLATE	DESCRIPTION	UNIT
BORE-JACK*2	Jack 2" PVC	LF
BORE-JACK*3	Jack 3" PVC	LF
BORE-JACK*4	Jack 4" PVC	LF
BORE-JACK*6	Jack 6" PVC	LF
BORE-JACK*2S	Jack 2" Steel	LF
BORE-JACK*3S	Jack 3" Steel	LF
BORE-JACK*4S	Jack 4" Steel	LF
BORE-JACK*6S	Jack 6" Steel	LF

VII.1.2. B-J/SET-UP_ plates are used to provide jacking and receiving pits for the above BORE-JACK* plates. This plate can accommodate up to 6 runs of conduit. Standard depth is 5' deep.

PLATE	DESCRIPTION
B-J/SET-UP	Set up pits to BORE-JACK up to 5' deep
B-J/SET-UP6	Set up pits to BORE-JACK up to 6' deep
B-J/SET-UP7	Set up pits to BORE-JACK up to 7' deep
B-J/SET-UP8	Set up pits to BORE-JACK up to 8' deep
B-J/SET-UP9	Set up pits to BORE-JACK up to 9' deep
B-J/SET-UP10	Set up pits to BORE-JACK up to 10' or deeper

VII.1.3. BORE-MOLE plates include any required excavation equipment, material and labor to install conduit by pushing, tunneling, or by using a hydraulic or pneumatic or percussion driven boring tool (MOLE) or any similar method which does not require a boring and jacking machine.

PLATE	DESCRIPTION	UNIT
BORE-MOLE*2	Install 2" PVC	LF
BORE-MOLE*3	Install 3" PVC	LF
BORE-MOLE*4	Install 4" PVC	LF
BORE-MOLE*6	Install 6" PVC	LF
BORE-MOLE*2S	Install 2" Steel	LF
BORE-MOLE*3S	Install 3" Steel	LF
BORE-MOLE*4S	Install 4" Steel	LF
BORE-MOLE*6S	Install 6" Steel	LF

VII.1.4. DIR-BORE plates include all required excavations, equipment, material and labor to install conduit by directional boring.

PLATE	DESCRIPTION	UNIT
DIR-BORE*1	Directional bore and install 1" conduit	LF
DIR-BORE*2	Directional bore and install 2" conduit	LF
DIR-BORE*3	Directional bore and install 3" conduit	LF
DIR-BORE*4	Directional bore and install 4" conduit	LF
DIR-BORE*6	Directional bore and install 6" conduit	LF

**TYPICAL
MULTIPLE DUCT IN CASING**

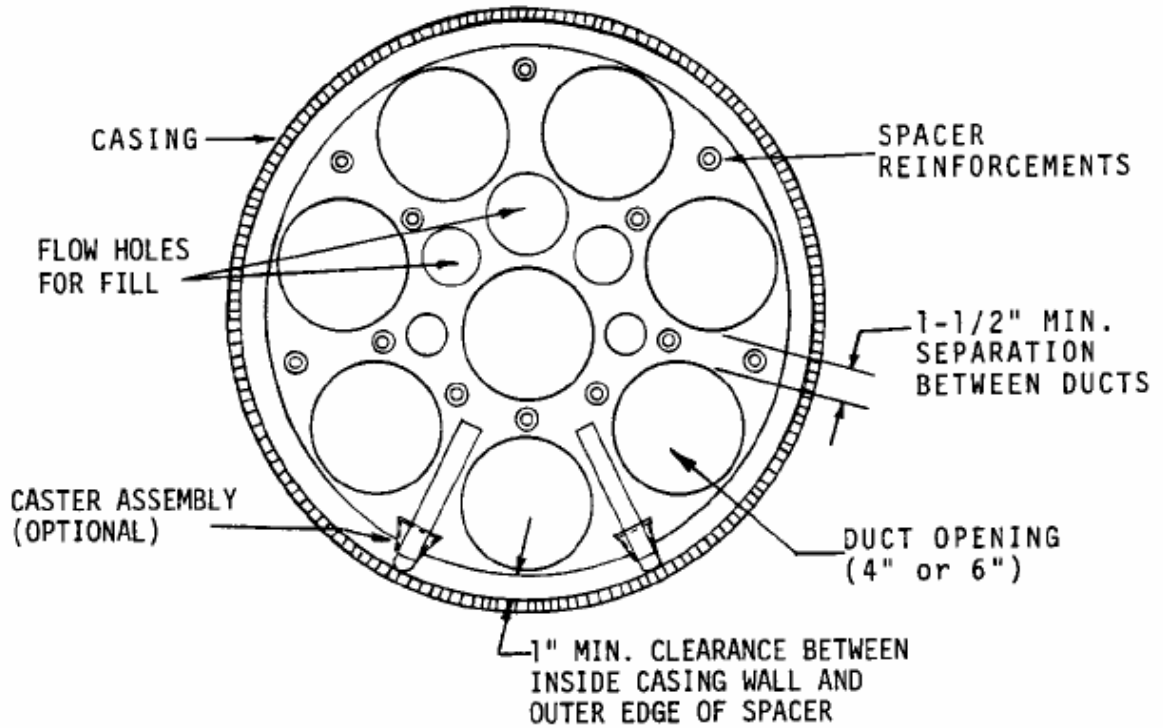

BORE SPACER

		Casing Diameter (OD)											
		14"	16"	18"	20"	22"	24"	26"	28"	30"	32"	34"	36"
Duct Size	4"	2	3	5	7	7	9	11	15	16	16	19	22
	6"	--	--	2	4	4	5	5	7	8	8	9	11
		Duct Per Casing											

Spacers will be installed at a maximum of 10' on centers.

* 1-1/2" Minimum separation between ducts

Conduit type should be fiberglass, heavy wall steel, or Schedule 40 PVC.

THIS PAGE INTENTIONALLY LEFT BLANK